

HONDA RS1000

ENDURANCE RACER

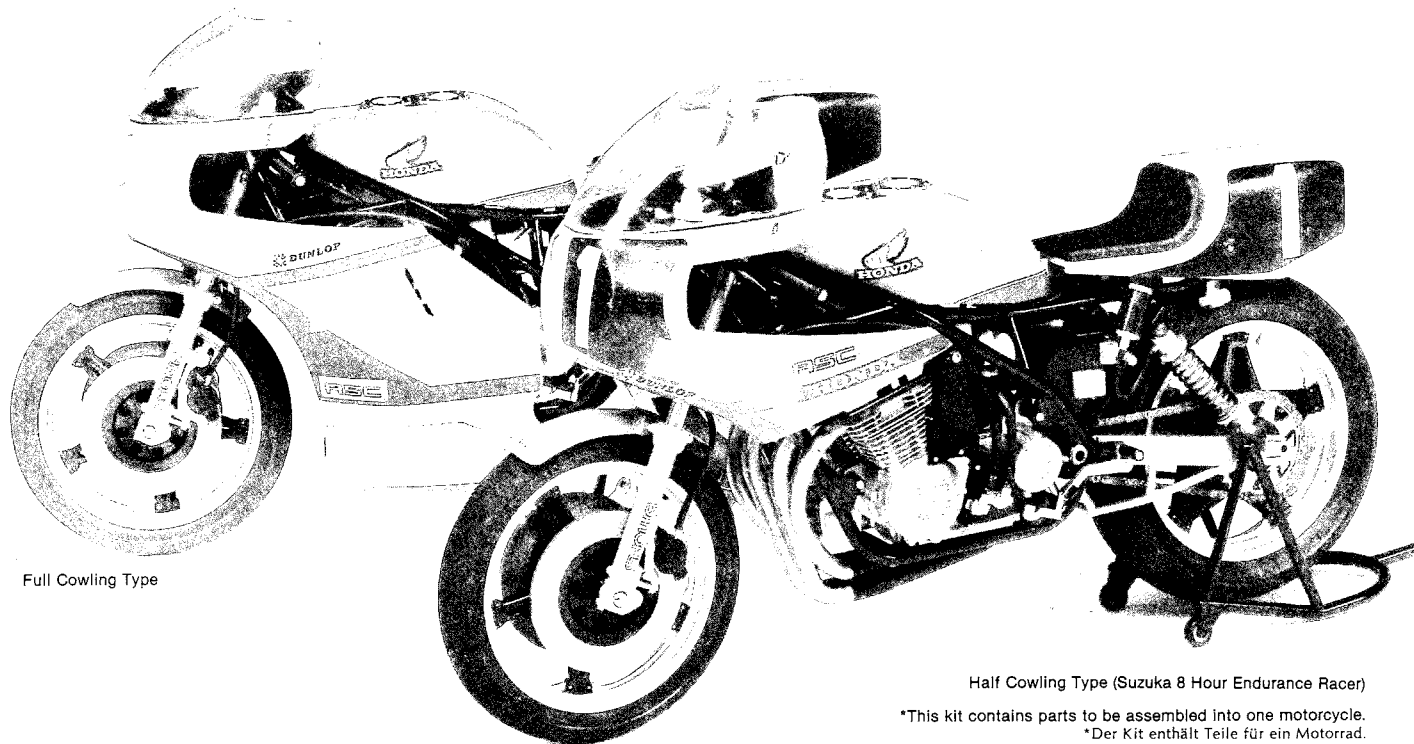

Full Cowling Type

Half Cowling Type (Suzuka 8 Hour Endurance Racer)

*This kit contains parts to be assembled into one motorcycle.
*Der Kit enthält Teile für ein Motorrad.

Motorcycle endurance racing received official sport status in 1980; however, Honda has been active in this type of racing for many years. Making their debut in 1976, Honda's RCB racer won 7 out of 8 races that year, and went on to capture the trophy four years running. Since becoming an official sport, with races mainly in Europe, the addition of a race in Suzuka Japan has made it international and endurance racing is becoming more popular

each season. Races must last at least 6 hours or 1000km and there are 10 races a season. The Bold'or 24 hour race is compared with the famous 24 hour Le Mans automobile event. What makes the endurance racing appeal to the spectator is that the bikes utilized in the races are production type machines, which look very much like the normal street machines seen every day. The RS1000 racer traces its history back to the Honda RCB of 1976. In 78 Honda released the CB750F which changed the engine from a SOHC to a DOHC 16 valve unit, and in 1980 the CB900F made its appearance. The present RS1000 is bored out to 999cc and produces 150hp. It has an aircooled four cylinder DOHC 16 valve engine and in 1980 it won 3 times in 7 races and became that year's Champion. The 1981 version of the RS1000 utilized conventional suspension with the exception of Anti Nose Dive Front Forks which were added prior to the seasons start. Small modifications are made each race to keep the machine competitive. The cowling is slightly larger than those of street bikes, to further protect the driver from fatigue during the grueling race. To Honda's regret, the Kawasaki motorcycle team became the world champions for 1981; however, Honda won the 8 hour Suzuka Japan race with Baldwin/Aldana as drivers and also the Bold'or 24 hour race, to the expectation of their many fans.

* * *
Motorrad "Endurance" Rennen wurde offiziell 1980 im Motorsport anerkannt. Honda war bereits seit vielen Jahren in dieser Sportart

aktiv. Die Honda RCB Renner machten 1976 ihr Debüt und gewannen in diesem Jahre 7 von 8 Rennen und auch die Trophäe 4 Jahre hintereinander. Seit Anerkennung im offiziellen Sport — hauptsächlich werden diese Rennen in Europa gefahren — machte das Rennen in Suzuka, Japan diese Sportart international und Endurance Rennen werden von Jahr zu Jahr mehr populär. Die Rennen müssen mindestens über 6 Stunden oder 1000 Kilometer gehen und pro Saison werden 10 Rennen gefahren. Das Bold'or 24 Stunden Rennen ist vergleichbar mit den 24 Stunden von Le Mans im Automobilsport. Das Interessante an den Endurance Maschinen ist, dass diese normale Produktionsmaschinen sind, die man jeden Tag auf den Strassen sehen kann. Die RS1000 geht zurück auf die Honda RCB von 1976. Es folgte dann die CB750F im Jahre 1978, bei welcher Honda den Motor von SOHC auf DOHC mit 16 Ventilen umstellte, 1980 von der CB900F gefolgt. Die jetzige RS1000 ist auf 999cc aufgebohrt und bringt 150 PS. Der Motor ist luftgekühlt hat 4 Zylinder und 16 Ventile DOHC. 1980 wurden von 7 Rennen bereits 3 gewonnen und die RS1000 wurde auch Champion. Die 1981 Version hatte die gewohnte Aufhängung, aber auch die Anti Nose Dive Vorderradgabel. Kleine Verbesserungen wurden vor jedem Rennen gemacht, um die Maschine konkurrenzfähig zu halten. Die Verkleidung ist etwas grösser als die der Strassenmaschinen zum Schutz der Fahrer. Zum Bedauern Honda's wurde das Kawasaki Team der Weltmeister 1981, jedoch gewann Honda die 8 Stunden in Suzuka mit Baldwin/Aldana als Fahrer und auch die 24 Stunden von Bold'or.

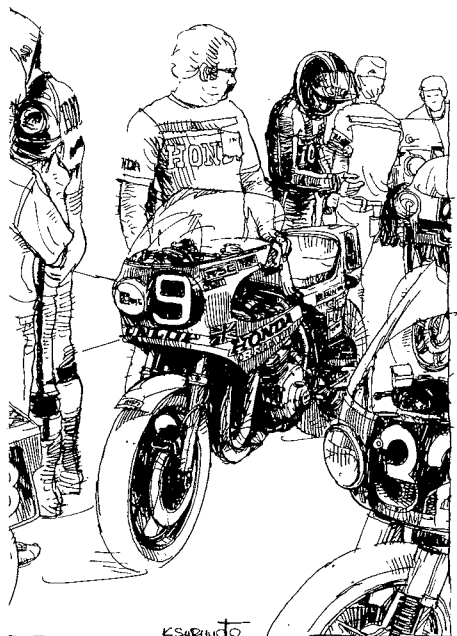

READ BEFORE ASSEMBLY.

**ERST LESEN
— DANN BAUEN.**

- ★ Study the instructions and photographs before commencing assembly.
- ★ You will need a sharp knife, a screwdriver, a file and a pair of pliers.
- ★ Use cement sparingly. Use only enough to make a good bond.
- ★ Apply cement to both parts to be joined.

● This mark denotes paint color, with color names and numbers for Tamiya Acrylic Paints & Paint Markers. Page 8 has detailed painting instructions; however, some parts should be painted prior to model's completion, and these are called out during assembly.

★ Vor Beginn die Bauanleitung studieren und den Nummern nach die Elemente zusammenbauen.

★ Bauteile nicht vom Spritzling abbrechen, vorsichtig abschneiden oder abwickeln. Teile vor Kleben zusammenhalten, auf genauen Sitz achten. Nicht zuviel Klebstoff verwenden. Kleine Teile hält man mit Pinzette fest.

★ Abziehbilder vorsichtig von der Unterlage im Wasser abschieben, auf richtigen Sitz achten und gut trocknen lassen.

● Dieses Zeichen zeigt die Farbe und Farbnummer der Tamiya Acryl-Farben und Paint Marker.

**2 «Completed Engine»
«Kompletter Motor»**

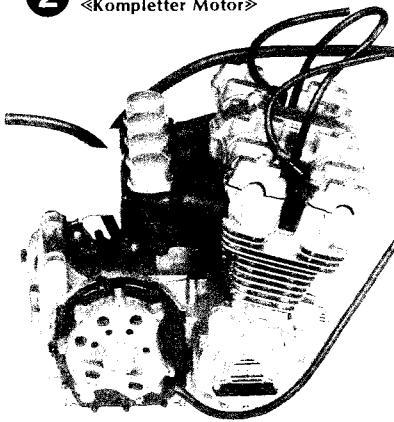

Do not break parts away from sprue, but cut off carefully with a cutting tool.
Bauteile nicht vom Spritzling abbrechen, vorsichtig abschneiden oder abwickeln.

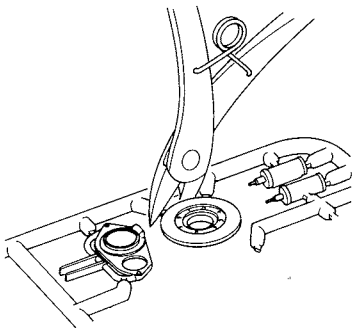

**1 Engine Parts Assembly
Motorenbau**

«Carburettor»
«Vergaser»

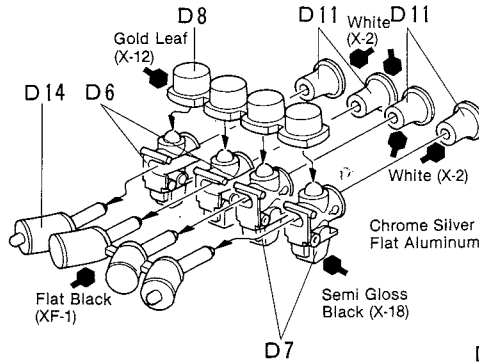

«Crankcase»
«Kurbelgehäuse»

Oil Breather Hose
Öl-Entlüfterschlauch
Thick Vinyl Tubing : 4 cm
Dicker Vinylschlauch:
4 cm

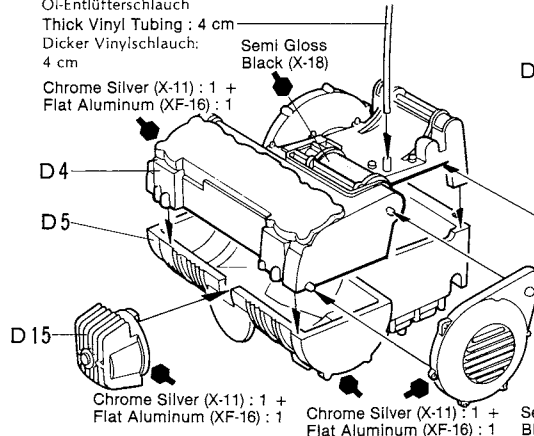

«Cylinders»
«Zylinder»

Plug Wire B
Zündkabel B
Thin Vinyl
Tubing : 4.5 cm
Dünnere
Vinylschlauch:
4.5 cm

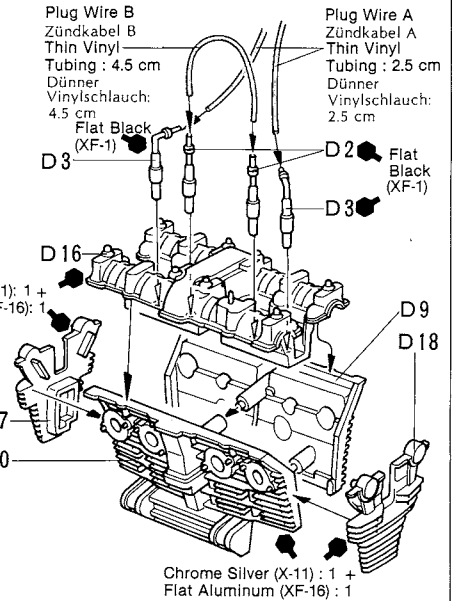

**2 Engine Assembly
Motor Endmontage**

Cylinders
Zylinder

Carburettor
Vergaser

Crankcase
Kurbelgehäuse

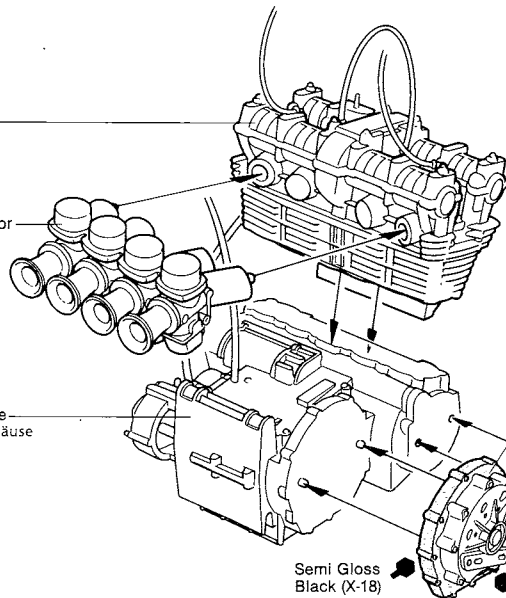

«Clutch Wire»
«Kupplungszug»

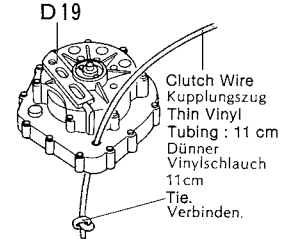

D12 ● Chrome Silver (X-11) : 1 + Flat Aluminum (XF-16) : 1

Semi Gloss Black (X-18)
Chrome Silver (X-11) : 1 + Flat Aluminum (XF-16) : 1

11 cm
7 cm
6 cm
5 cm
4.1 cm
4 cm
2.1 cm
2 cm

3 <<Assembly of Oil Tank>> <<Öltank Montage>>

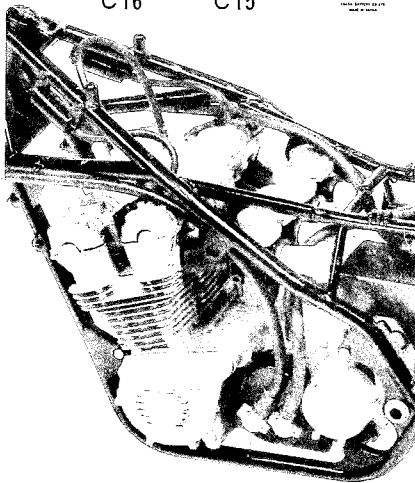
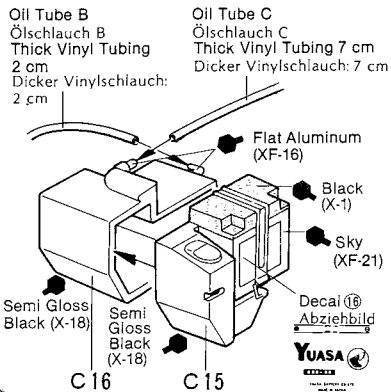

5 <<Completed Swing Arm>> <<Hintere Radgabel>>

Pass chain.
Kette durchlassen.

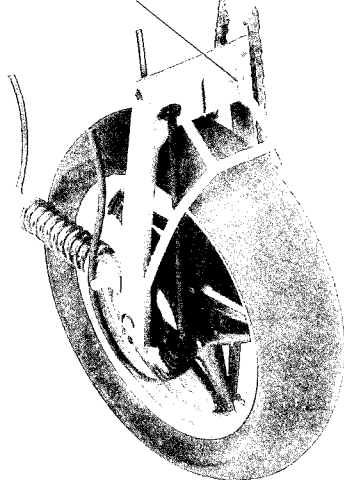

Before cementing plated parts, remove plating with a knife etc. from the surface to which cement is applied.

Chrometeile: Vor dem Kleben muss an den Klebestellen die Chromschicht abgeschabt werden, da sonst Klebstoff nicht bindet.

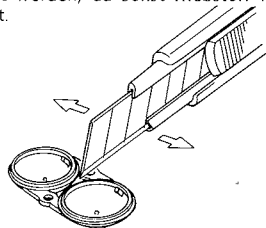

3 Installing Engine into Frame Motor in Rahmen Einbau

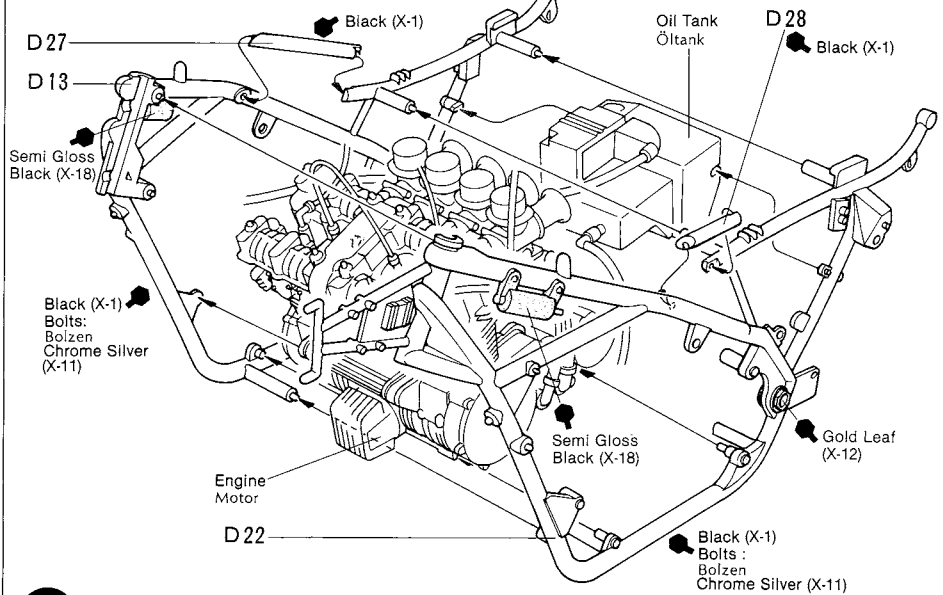

4 Assembly of Rear Wheel Hinterrad Montage

<<Rear Shock Absorber>>
<<Hintere Stossdämpfer>>

★ Make 2 sets.
★ 2 Sätze für rechts und links machen.

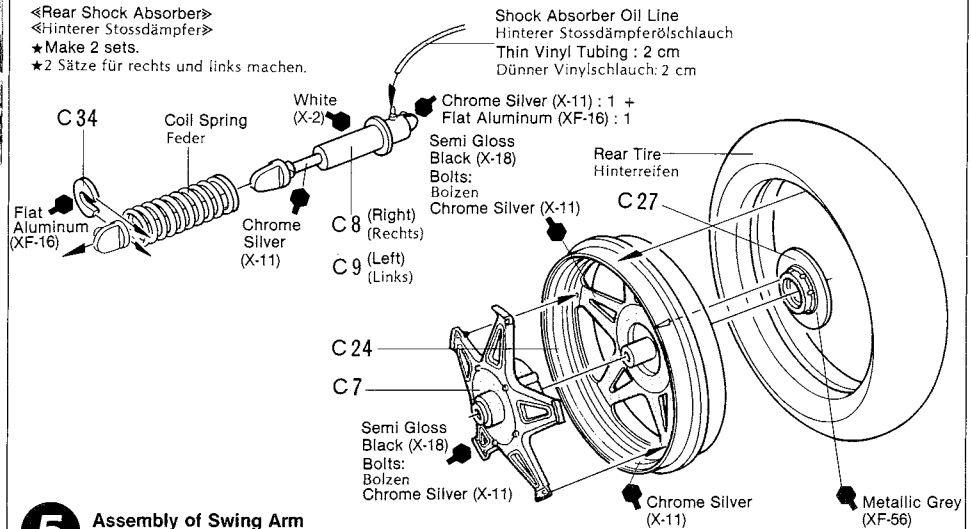

5 Assembly of Swing Arm Radgabel Montage

Rear Shock Absorber (Right)
Hinterer Stossdämpfer (Rechts)

Semi Gloss Black (X-18)

Chrome Silver (X-11) : 1 + Flat Aluminum (XF-16) : 1

C 17

C 35

C 19

C 1

Gun Metal (X-10)

C 36

Rear Brake Line
Hinterer Bremsschlauch
Thin Vinyl Tubing : 5 cm
Dünnere Vinylschlauch: 5 cm

C 17

Semi Gloss Black (X-18)

Chrome Silver (X-11) : 1 + Flat Aluminum (XF-16) : 1

C 35

C 19

C 1

Gun Metal (X-10)

C 36

Rear Wheel Hinterrad

Rear Shock Absorber (Left)
Hinterer Stossdämpfer (Links)

Gold Leaf (X-12)

1.6mm x 20 Screw /Schraube

Chrome Silver (X-11) : 1 + Flat Aluminum (XF-16) : 1

6 «Attached Swing Arm»
«Eingebaute Radgabel»

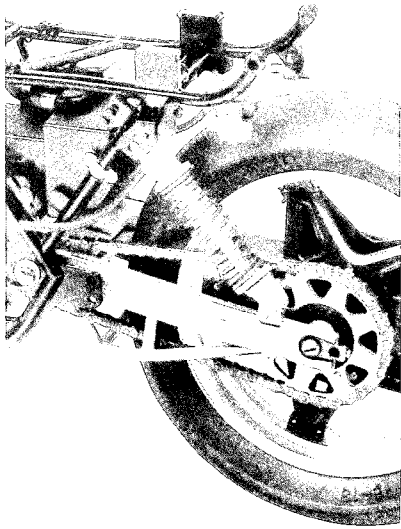

6 Attaching Swing Arm
Einbau der Radgabel

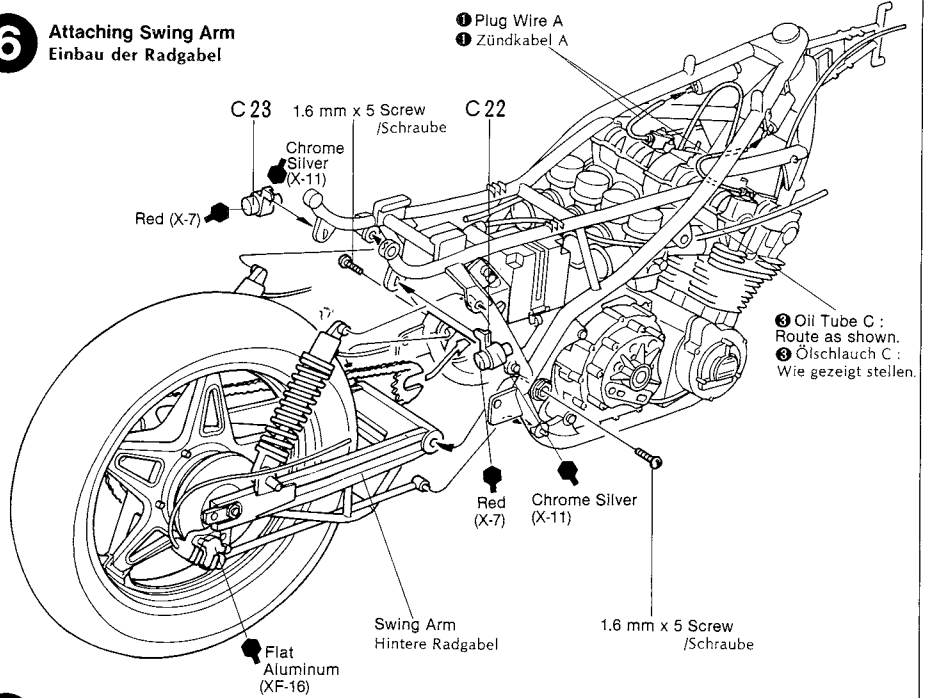

7 «Assembly of Muffler»
«Auspuff Montage»

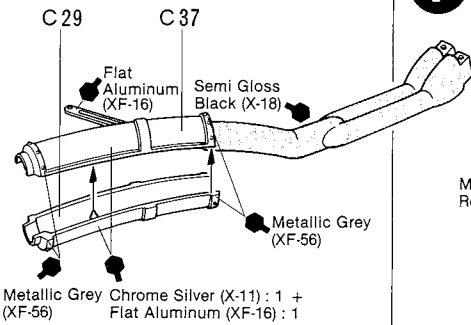

7 Attaching Muffler
Auspuff Einbau

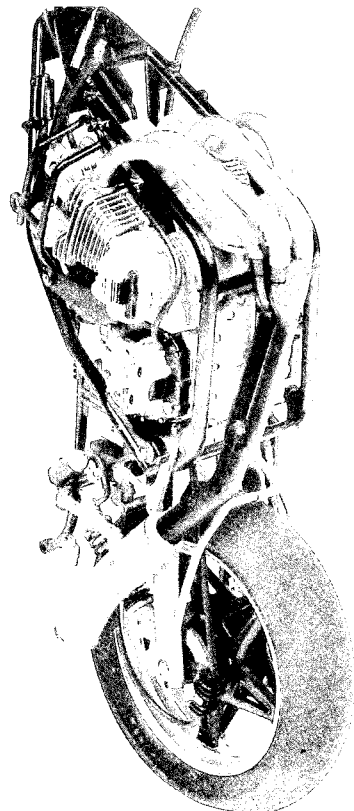
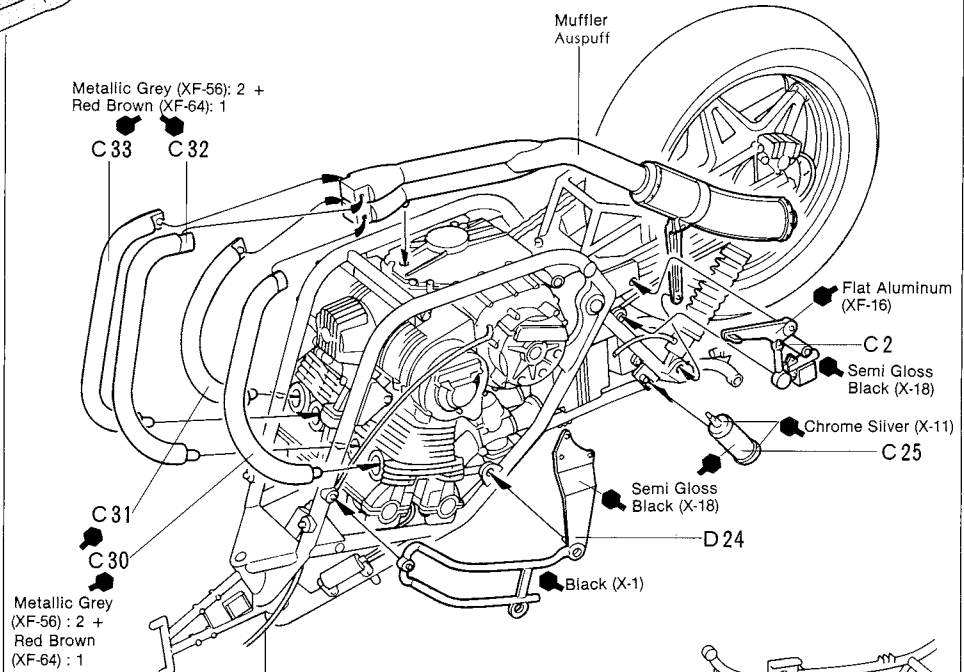

② Clutch Wire : Route as shown.
② Kupplungszug : Wie gezeigt stellen.
«Rear Brake Lining»
«Verkabelung»

④ Shock Absorber Oil Line
④ Hinterer Stossdämpferschlauch
⑤ Rear Brake Line
⑤ Hinterer Bremsschlauch

5.5
cm
5cm

8 «Attached Oil-Cooler»
«Eingebautes Ölkühler»

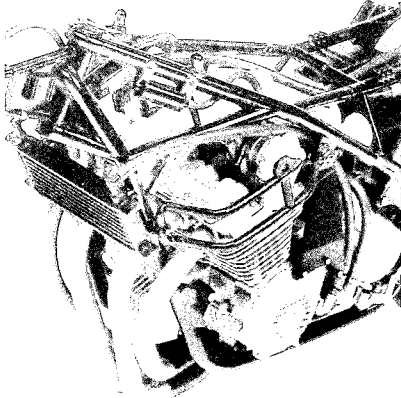

10 «Completed Front Fork»
«Komplette Vorderradgabel»

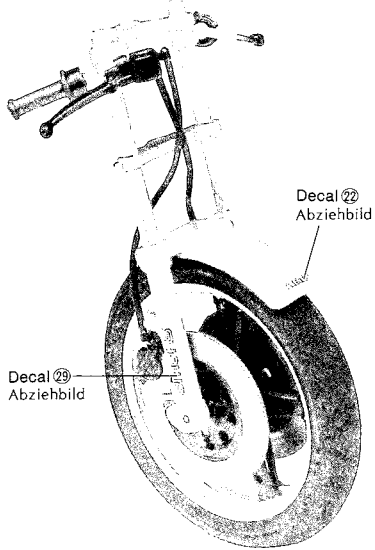

«Assembly of One-touch Jack/Stand»
«Radheber»

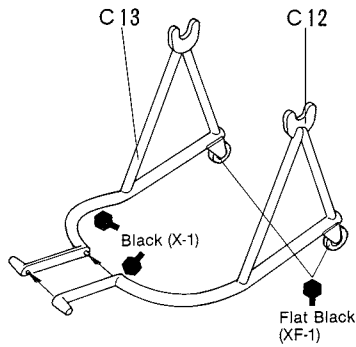

«How to use one-touch jack»
«Radheber im Einsatz»

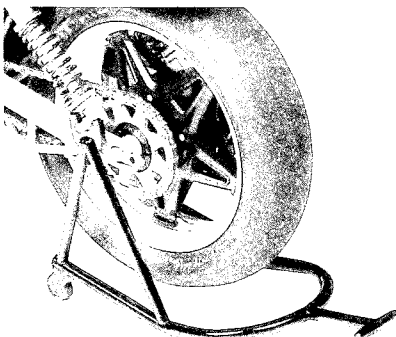

8 Attaching Oil-Cooler
Ölkühler Einbau

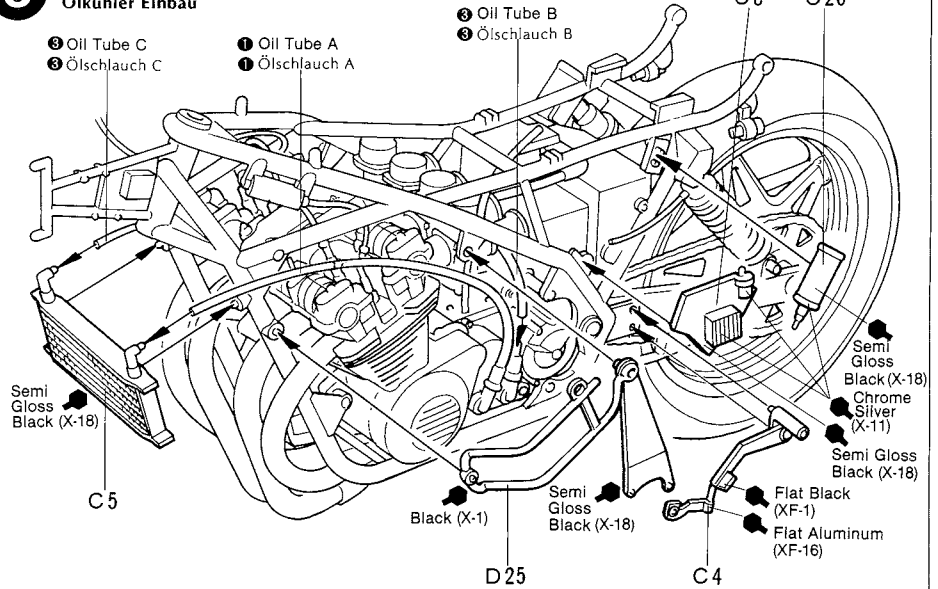

9 Assembly of Front Wheel
Vorderrad Montage

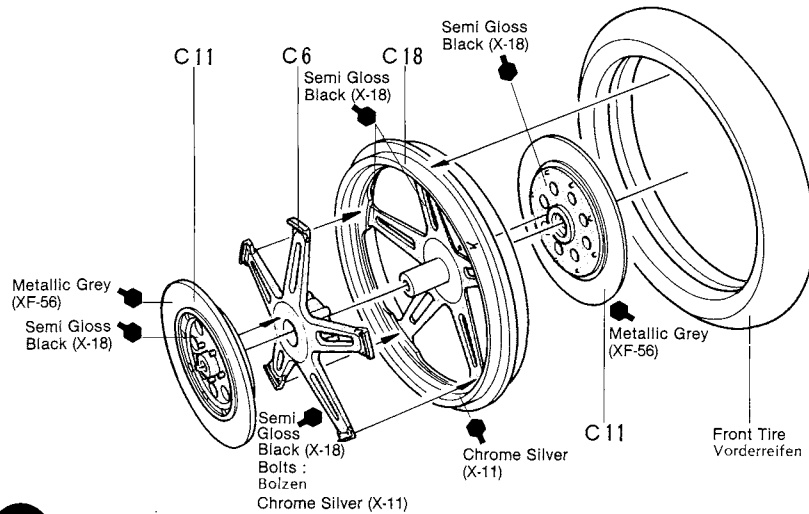

10 Assembly of Front Fork
Zusammenbau der Vorderradgabel

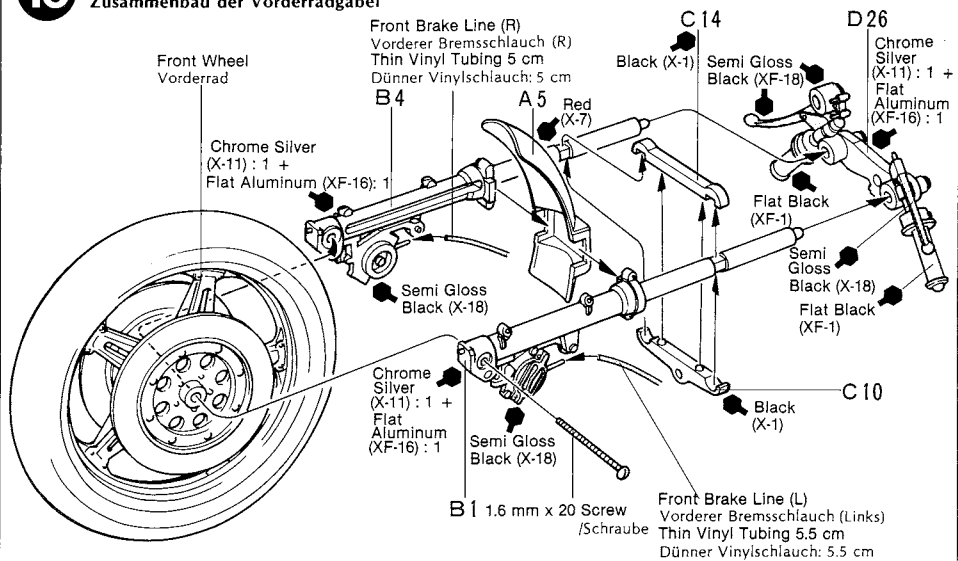

12 «Marking of Tank»
«Tank Markierung»

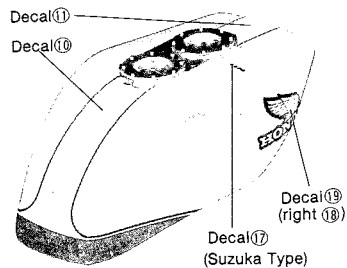

«Marking of Saddle»
«Sattel Markierung»

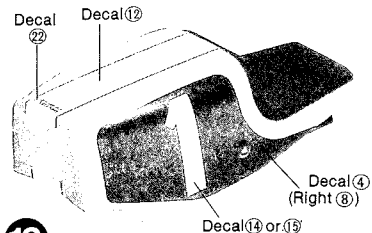

13

You can choose either the half cowlng seen at Suzuka or full cowlng seen in Europe. If you are going to attach a full cowlng, cut as shown.
Man kann entweder die halbe Verkleidung von Suzuka oder die volle Verkleidung wie in Europa anbringen.

Full Cowlng : Cut Out
Volle Verkleidung :
abschneiden

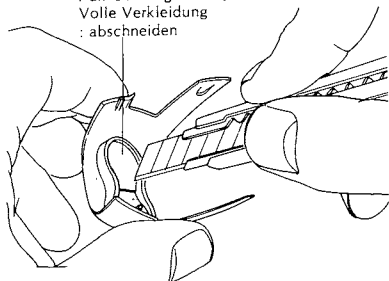

«Suzuka 8 hour Endurance Racer»
«Suzuka 8 Stunden Endurance Renner»

Decal 2 Decal 9 Decal 24 Decal 6 Decal 5

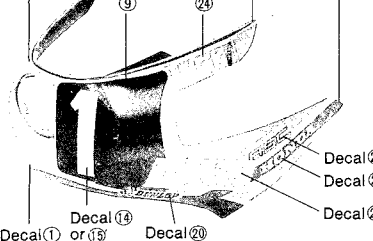

«European Racer»
«Europa Renner»

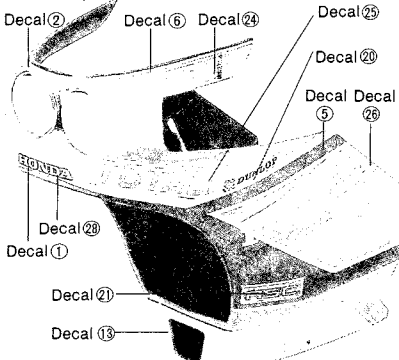

11

Attaching Front Fork
Einbau der Vorderradgabel

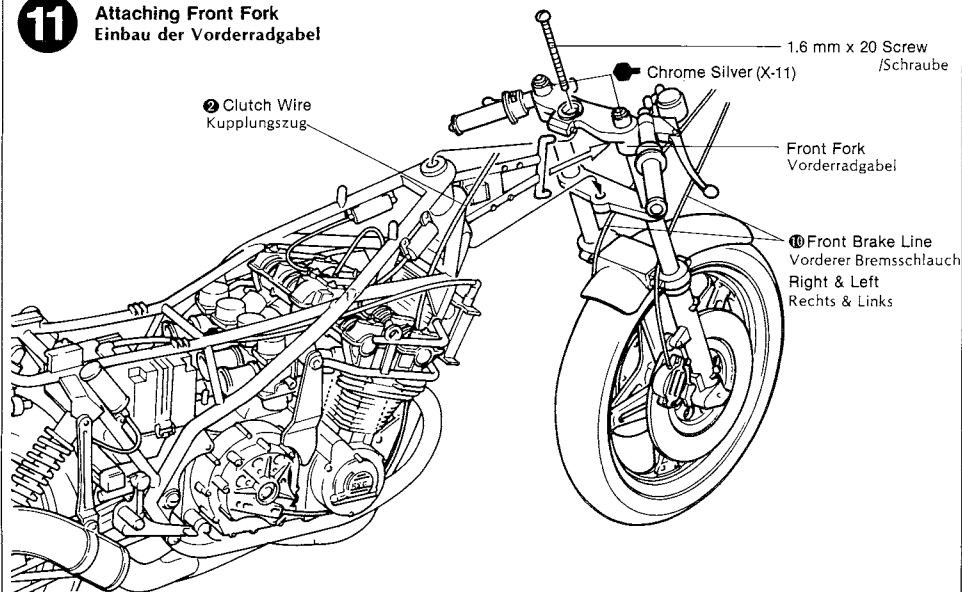

12

Assembly of Fuel Tank & Saddle
Tank & Sattel Montage

«Fuel Tank»
«Tank»

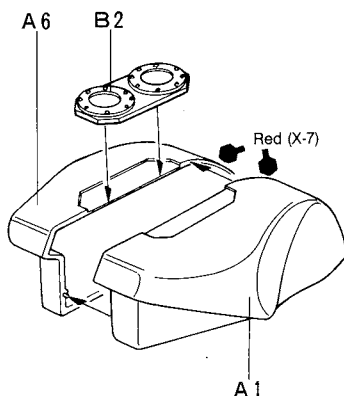

«Saddle»
«Sattel»

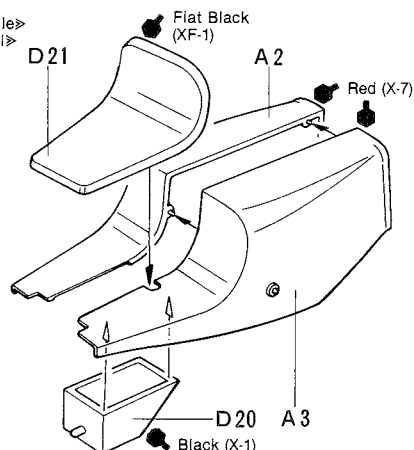

13

Assembly of Cowlng
Verkleidung Montage

«Headlight»
«Scheinwerfer»

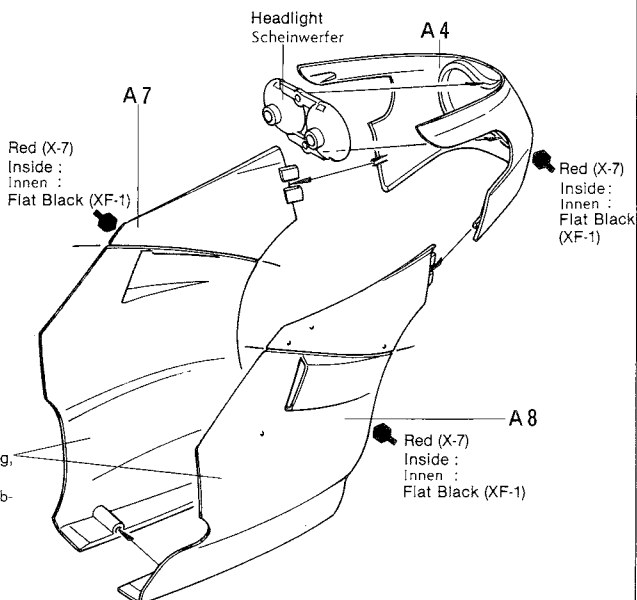
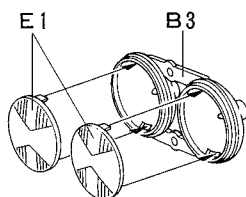

★ If you are going to use half cowlng, cut it off.
★ Halbe Verkleidung: untere Teile abschneiden, siehe Photo links.

15 <<Attaching Half Cowling>>
<<Anbringung der halben Verkleidung>>

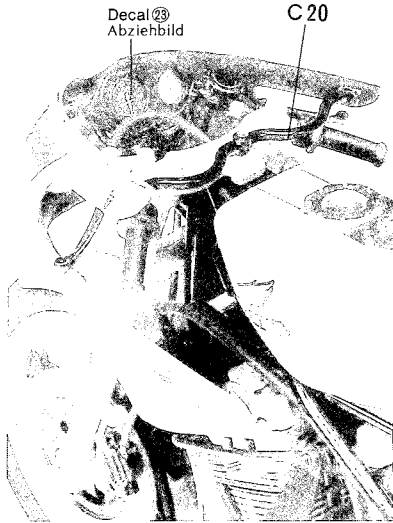

**BUILD A COLLECTION OF TAMIYA
PRECISION MOTORCYCLE MODELS**

1/12 HONDA VT250F

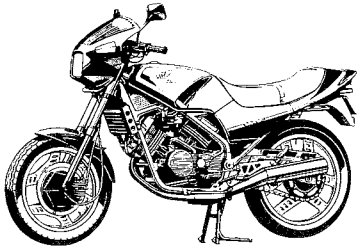

1/12 HONDA VFR750R

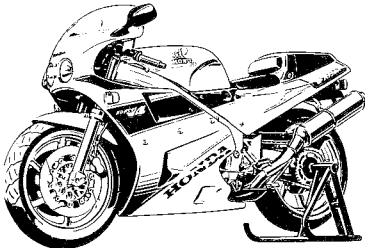

1/12 SUZUKI GSX1100S KATANA

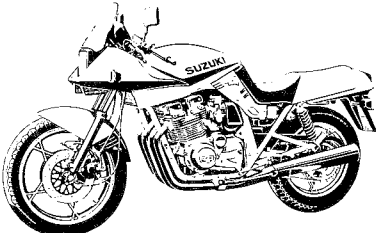

1/12 KAWASAKI KR1000F
ENDURANCE RACER

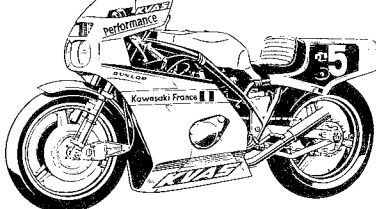

14 Attaching Fuel Tank & Saddle
Tank & Sattel Einbau

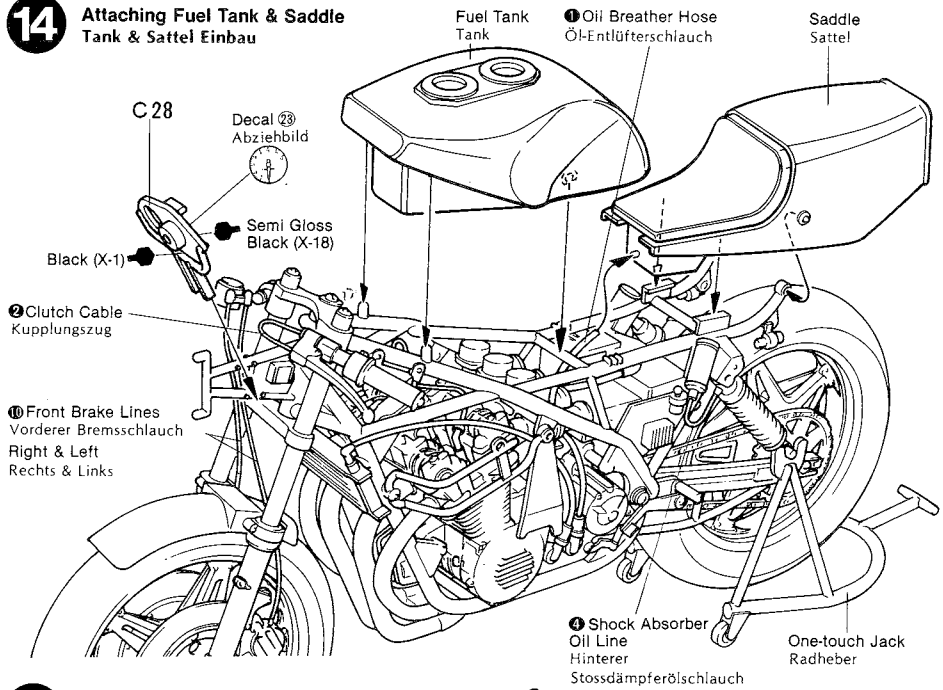

15 Attaching Cowling
Verkleidung Einbau

<<Suzuka 8 Hour Racer — Half Cowling>>
<<Suzuka 8 Stunden Rennen — halbe Verkleidung>>

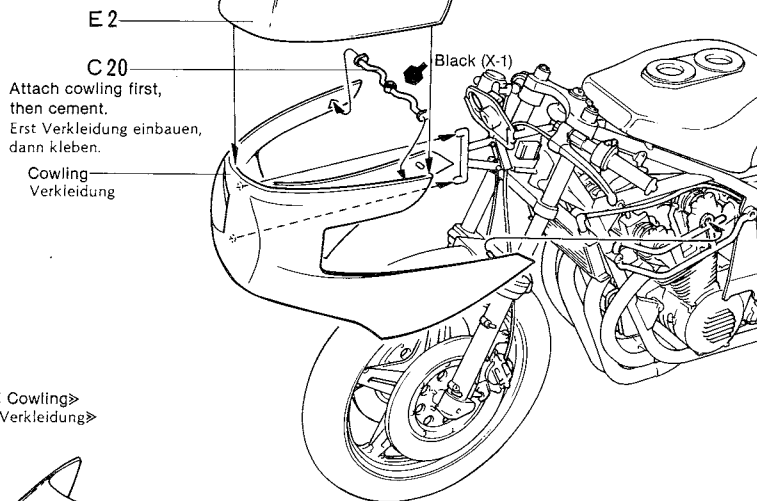

<<European Racer — Full Cowling>>
<<Europa Renner — volle Verkleidung>>

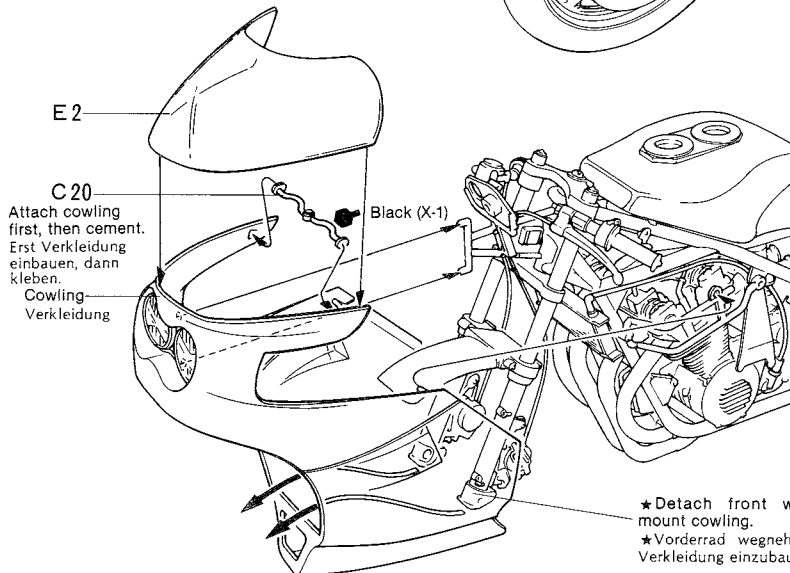

*Detach front wheel to mount cowling.
*Vorderrad wegnehmen, um Verkleidung einzubauen.

PAINTING

<Suzuka 8 Hour Endurance Racer 1981>

APPLYING DECALS

<Painting of Honda RS1000>

Honda's endurance racing colors are Red; White and Blue, and differ a little at each race. Frame is gloss black. Tank, cowl, fender and saddle back are red, with a narrow side strip of blue outlined in white. A white band runs down the center of the tank. Sponsor decals are used only on the cowl. Half cowl was used in the Suzuka Japan race.

<Bemalung der Honda RS1000>

Die Honda Endurance Farben sind rot, weiss und blau und sind in jedem Rennen etwas verschieden. Der Rahmen ist schwarz-glänzend, der Tank, die Verkleidung und die Schutzbleche sowie die Satteldrückseite sind rot mit einem engen Seitenstreifen in blau mit weisser Ausenlinie. Ein weisses Band geht über die Mitte des Tank's. Sponsor Decals sind nur auf der Verkleidung. Eine kürzere, halbe Verkleidung wurde in Suzuka verwendet.

<Colors Required>

<Farbe>

- ★Tamiya Acrylic Paint
- Black X-1
- Royal Blue X-3
- Red X-7
- Gun Metal X-10
- Semi Gloss Black X-18
- Flat Black XF-1
- Flat Aluminum XF-16
- Sky XF-21
- Metallic Grey XF-56
- Red Brown XF-64
- ★Tamiya Paint Marker
- Chrome Silver X-11
- Gold Leaf X-12

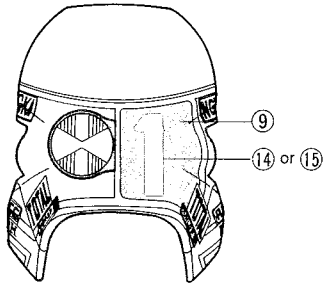
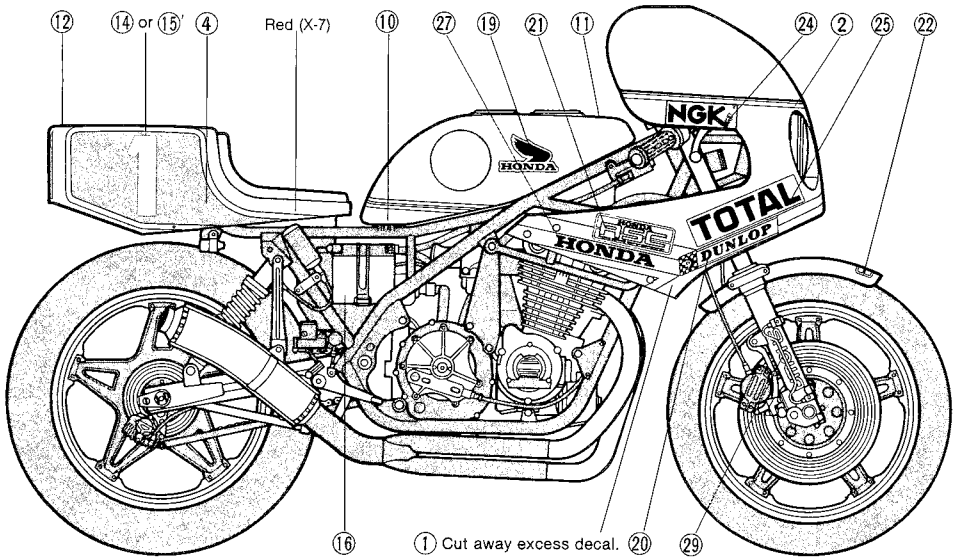
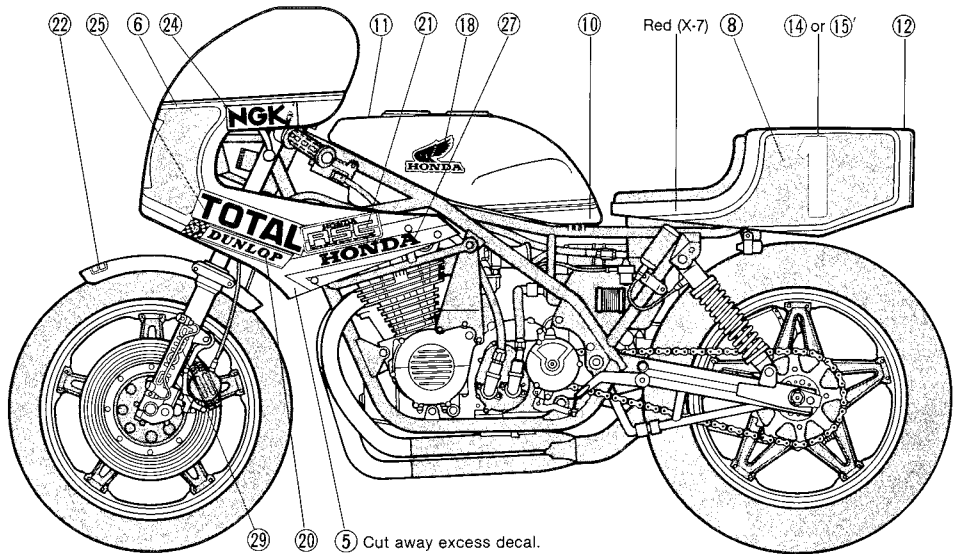

<European Endurance Racer> Other cowl marks are same as Suzuka 8 Hour Endurance Racer.

