

HONDA

1/6 CB750 FOUR



1:6 SCALE

SUPER DETAILED HONDA FOUR ENGINE
REALISTIC ACTION OF FRONT & REAR SUSPENSION
PLENTIFUL METAL PARTS
SUPER DETAILED PNEUMATIC RUBBER LIKE TIRES

ITEM 16001
BIG SCALE

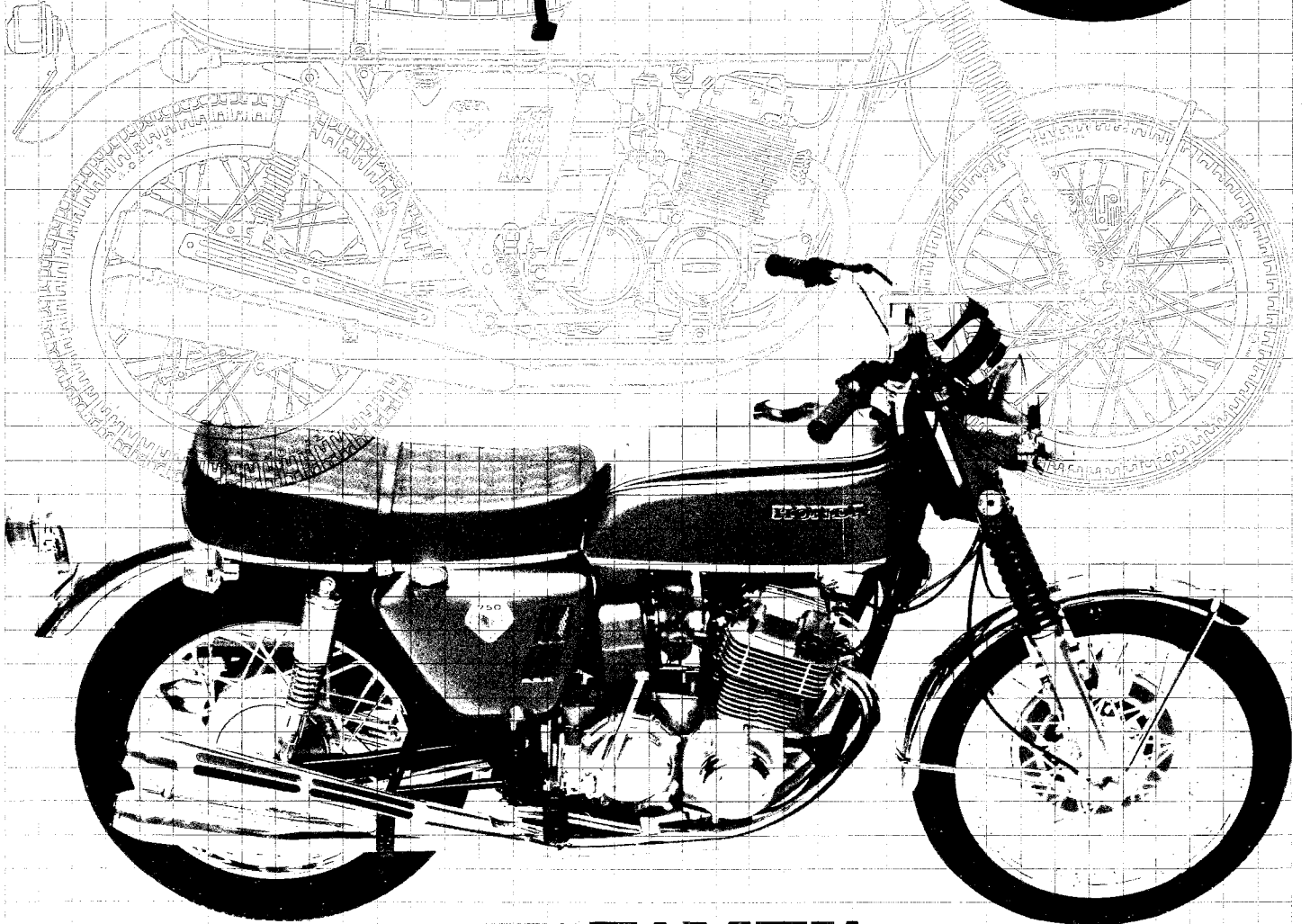
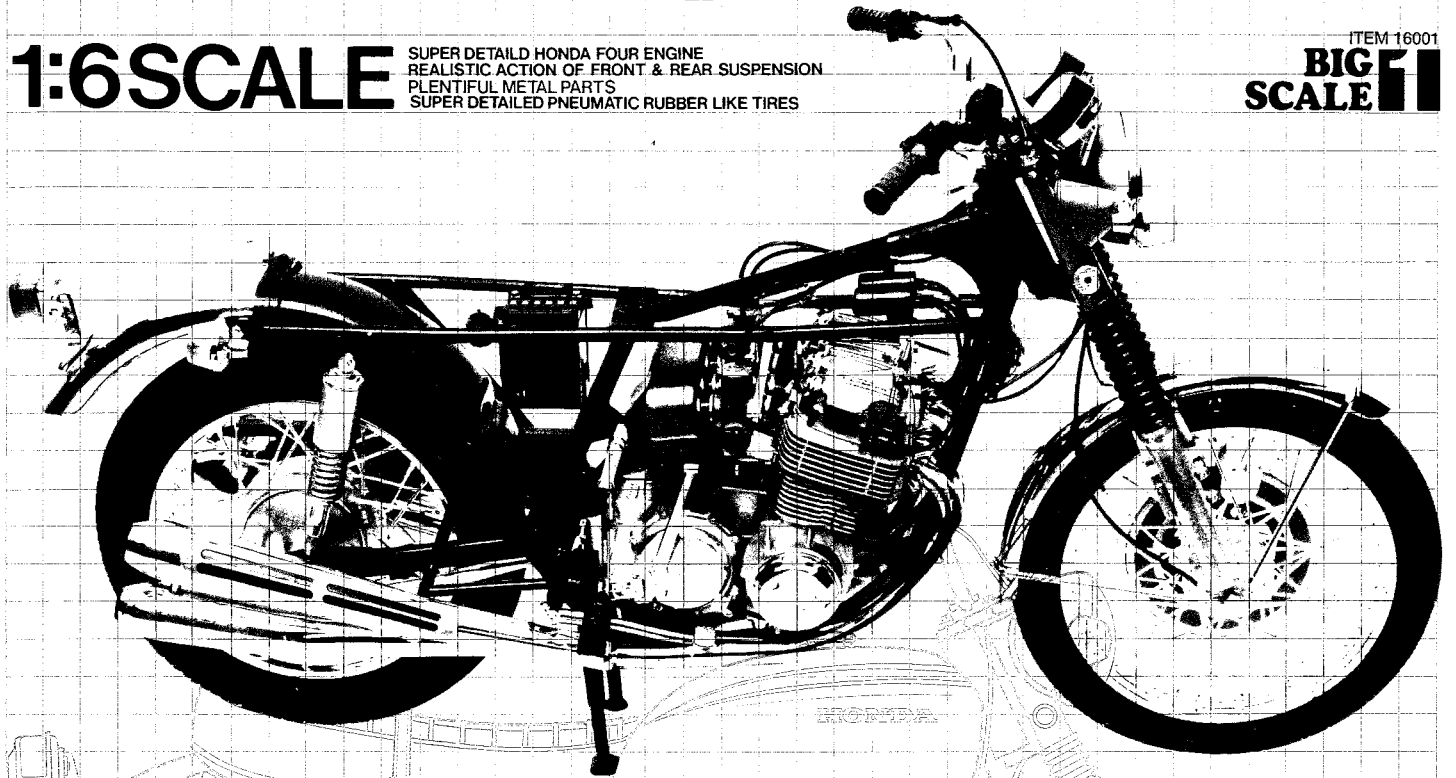

TAMIYA

TAMIYA, INC. 3-7, ONDWARA, SHIZUOKA-CITY, JAPAN.

Background History of the Honda CB750 Four:

In the U.S. where motorization has advanced to such a degree, all the cars produced are larger in body and engine capacity than foreign cars. Likewise, motorcycles made in U.S.A. are larger in body and engine capacity. There is even a motorcycle with an engine capacity of 1,200c.c. well equivalent to that of a small car. The motorcycle is being produced by the Harley Davidson corp., the only mass-production maker in the U.S. One of the main reasons for such a motorcycle is that the U.S. has a network of broad highways extending in all directions over the vast land. In these highways a substantial high-speed not less than 100km is allowed. Highways with such a high speed limit gave birth to a heavy-weight motorcycle called "roadster". To speed along on these highways, it is essential for a motorcycle to have a large engine capacity to enable a high speed, durability to facilitate continuous riding for long hours and stability at high speed. A motorcycle with such performance necessarily leads to a heavy motorcycle with large displacement. If we take an actual case, it will be readily understood which of the two is easier to ride in every way—a car with a maximum speed of 150km/h or one with that of 200km/h. In 1959, the Honda Company of Japan established the Honda America inc. in the U.S. to start a full-fledged export thereto. With this beginning, the Honda motorcycle gradually gained popularity among the Americans. One of the potential reasons for such a popularity was that the Honda won overwhelming victories in many motorcycle Grand-prix races.

Just one month before establishment of the Honda America, the Honda's entry won the 6th place in the T.T 125c.c. race held in the Man Isle in Britain, which is one of the biggest motorcycle GP race in the world. It should be added that this was its first entry in the race of this kind.

With this successful start, the Honda cheerfully advanced on the road to successive victories in the motorcycle GP races. Almost three years after the initial victory, the Honda had no rival in those races. Year after year, it continued to win. Indeed, in 1961, it won all the five places from the top in both 125c.c. and 250c.c. classes T.T races. It was a great feat. Eventually, two other Japanese motorcycle makers, the Yamaha and the Suzuki joined the Honda to overwhelm foreign participants in every class races of the motorcycle GP events. In 1968 when the Honda Factory Team withdrew from the GP races, the name of "the Honda of motorcycle" was world-famous. And as a saying goes that "a race is a laboratory on the run", the Honda feedbacked all the valuable technology and experiences gained during the races to the mass-produced products which led to a better and better motorcycle with increasingly higher performance. The SOHC, double-row, 2-cylinder engine of the CB72, antecedent of the current CB250 and the series 4-cylinder engine of the Honda sports-cars like the S600 and the S800—all these superior products are intensive technical achievements directly resulting from experiences in those races. Further, the Honda's prominent

activities including two GPs win in the F1 races, events for the racing-cars during 1964 to 1968, served to impress the image of high-performance not only of the Honda cars but also the motorcycles. The fact was there for all to see. Anyway it was certain that the Honda had since gained a wide popularity day by day. However, this popularity was limited to smaller displacement motorcycles and the market for the heavy, large displacement motorcycles of more than 500c.c. was exclusively shared by such ones as the British Triumph and BSA, the German BMW and the U.S. Harley Davidson.

It was to intrude into this heavy-motorcycle market that the Honda introduced the CB450. Its 450c.c. engine worked on a 4-cycle, 2-cylinder DOHC mechanism just like the one of any GP racer. This engine mechanism enabled such a

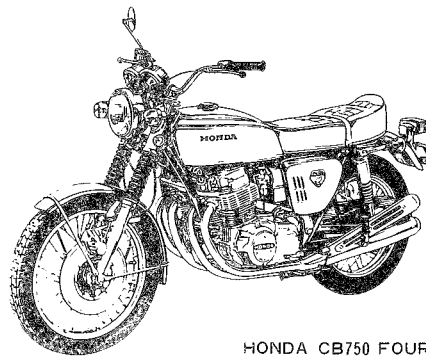

HONDA CB750 FOUR

high performance as a maximum speed of 180 km/h and 13.2-second acceleration time in S.S. 1/4 mile.

This high performance could match that of a heavy-class machine, one class above its own. Even that of a Harley-Davidson's Electraglide 1200c.c., a motorcycle with the world's largest displacement was far below the CB450's. In fact, the Electraglide's maximum speed reaching 158km/h and acceleration time of 14.7 seconds in S.S. 1/4 mile was no match for the CB450's. With this equal or much superior performance, however, the CB450 was still the CB450 and it was said that the CB450 lacked the peculiar "relish" of a heavy motorcycle. Also, in its early type, the CB450 had a clumsy-shaped fuel tank slenderously described as a camel's back. Due to these minus factors, the CB450 could not threaten superiority and popularity of the large engine-power motorcycles of the U.S. and Europe.

In the spring of 1969, the Honda introduced its first heavy-class motorcycle, the CB750 Four. Its aim, of course, was to capture some of the last heavy motorcycle market still left in the U.S. Later in the summer, the motorcycle was put on the market in Japan and opened a heavy-class motorcycle market in the Japanese motorcycle world.

Mechanism

Engineers of the Honda said that the CB750 was produced and based on a designing idea to "make the long-distance touring on highways safer and more comfortable". The idea could be realized when a motorcycle gifted with a combination of the following three elements was produced: Engine with a great reserve of power, superior stability during the run and a reliable brake.

The CB750 has a displacement of 750c.c. (736 c.c. to be exact) as its name shows. The figure stands as the largest one for any motorcycle produced in Japan. But when compared with those of its counterparts throughout the world, such a displacement was not a rare example, although in case of a motorcycle with a 4-cylinder engine, only two or three examples are known. Further, such a motorcycle is produced in a very small, limited number, while the CB750

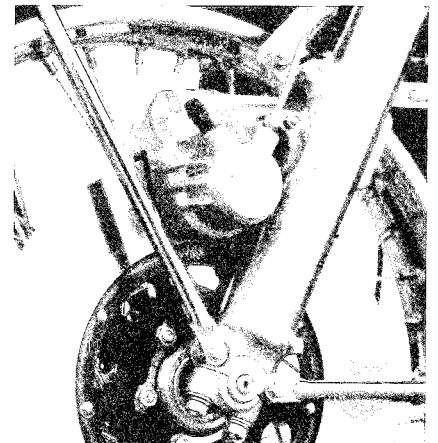

Front Disc Brake

is a mass-produced one being monthly produced by 2,000. Such a mass-produced one does not exist except the CB750. The CB750, therefore, has a great appeal just as the high-performance GT car like the Ferrari and the Lamborghini with a V-type, 12-cylinder engine in the world of the cars.

The reason why the Honda adopted this 4-cylinder engine was to hold down vibration of engine. In the case of a 4-cycle engine, a single cylinder engine has one explosion during two revolutions of crankshaft. In a 2-cylinder engine, one revolution for one explosion while with a 4-cylinder engine, two explosions during one revolution. The 4-cylinder engine, therefore, enables smooth revolution of crankshaft, by reducing engine vibrations. Needless to say, with reduced vibrations, more comfortable movement of the motorcycle can be expected while the rider will have less fatigue. However, design of a parallel, 4-cylinder engine necessarily leads to a broad engine, much wider in breadth.

Engine of a motorcycle must be designed extremely compact. Especially its breadth must be as narrow as possible. It is absolutely necessary in order to get a better riding position, a deeper bank angle during cornering and also to reduce frontal area so that less air resistance will result. The Honda's effort to produce a compact engine is also shown in the fact that the Honda has unusually adopted engine of a long-stroke type such as this. In an engine of this type, stroke of a piston (distance of vertical piston motion) is much longer than piston diameter. But in general, most engines of the current motorcycles excepting of the off-road type, are either of a square type in which bore is equal to stroke, or of an over-square one where bore is much longer than stroke. This is because such a bore-stroke relationship is much favourable to get a larger power as it increases number of engine revolutions. However, if displacement is the same, cylinder diameter (e.i. bore) of such an engine is much longer than that of a longer-stroke engine, and the engine breadth, more wider. In the case of the CB750, even though its engine is of a long-stroke type, resulting decrease of engine power poses little problem. In fact, it is proud of the world's highest power amounting to 67ps. The real problem, therefore, is rather that of engine design and how to get the engine more compact in shape and body. Its power of 67ps amounts to 91ps when calculated in terms of ps per litre. This looks rather small when placed beside 120ps per litre of the CB250 which is also produced by the same Honda. The Honda engineers said that this was because they tried to have an engine gifted with balanced power and torque per each revolution by checking increase of power itself. Engine of the CB750, therefore, has been designed substantially easier to handle when its high displacement and power is taken into consideration. As a result, the

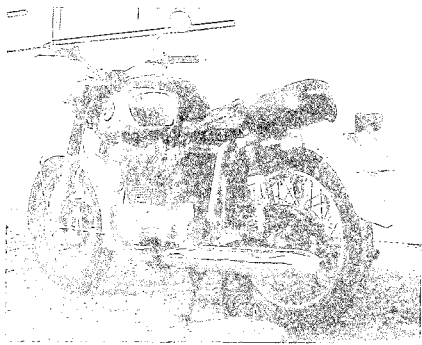

HONDA CB450

Supervision of

● HONDA MOTOR Co, Ltd.

● HONDA R & D Co, Ltd.

CB750 will be described as a uninteresting machine from the viewpoint of a veteran rider. Being compact, SOHC mechanism contains only a single cam shaft on the cylinder-head. The mechanism has an important point not easily passed over. The CB450, on the other hand, adopts DOHC mechanism. OHC stands for Overhead Cam Shaft. The mechanism directly opens and closes intake and exhaust valves by means of cam shaft on the head of cylinder. The mechanism is useful as it facilitates high-speed revolution of engine. The difference between SOHC and DOHC is that one uses only a single cam shaft (Single) while the other, two (Double). In the case of Single OHC, a single cam shaft opens and closes intake and exhaust valves while in Double OHC, two cam shafts do the same separately.

Of the two mechanisms, DOHC work better and could show high performance. But as its efficiency increases and performance gets higher, its mechanism always becomes more and more complicated. This problem of complication could not be avoided. In contrast, SOHC mechanism is relatively simple without entailing undue complication. The simpleness met the supreme demand on the part of the Honda to have a compact engine, and SOHC was adopted by the latter. The advantage in this case is clearly shown when the cylinder-head portion of the CB750 is compared to that of the CB450.

Lubrication of both engine and transmission portions is done by the dry-sump system. The system is complicated in mechanism and costs high. It is a rare case for the Honda to adopt the system on its machine. And most machines on the market rarely use the system. The usual system is the wet-sump on which suspends a large lubrication oil pan below engine. However, with this system, production of a compact engine is a hopeless task. For a compact engine, the dry-sump system is better suited. Besides this system has another advantage. In this system lubrication oil is placed much further from engine. Due to this removed location, rise of oil temperature by heat of engine and deterioration of oil eventually leading to inferior performance are prevented. Traces of many other efforts to produce a compact engine are evident in various portions such as crankshaft, bearing and others. The machine is equipped with a Keihin-made CW28 carburetter. For an engine of a parallel, 4-cylinder design, this one is surprisingly compact. Its power reaches 67ps/8,000r.p.m. and produces torque of 6.1kg/7,000r.p.m. With these power and torque, the engine can even make the big machine that weighs 202kg at a high speed of 200km/h.

Frame construction of the CB750, too, is a point that needs close examination. It was the first time for the Honda to adopt the double-cradle type. For, the Honda has never used the double-cradle type even in its GP racer which required the limit of performance. It has been usual with the Honda to adopt the diamond type which utilizes the engine as a part of frame to facilitate reduction of weight. Both the CB450 and the CB250 are considered to be machines of the cradle type. However, both machines are not those of the genuine double cradle type which builds up and reinforces each portion of a machine with two pipes laid in parallel. A machine built in a frame of the diamond type is delicately affected in its stability during cornering because twist due to the curve centers on other parts of the machine than the engine portion which is a rigid body. In the case of the double cradle type, this twist effect is dispersed over the whole body of the machine.

An artistically sharp effect, therefore, disappears. Instead, an almost imperceptible and more like a natural one is felt. The result is improvement of cornering performance. In fact, almost all the heavy machines of the world, which are said to be gifted with high cornering performance, adopt the double-cradle type construction. With

this machine, furthermore, proper values of wheel arrangement of caster and trail wheel-base, etc., and, fully-reinforced suspension facilitate better stability and driving property during high-speed movement. Also, confidence of the Honda's technical staffs in stability and maneuverability of the CB750 is such that the machine is not equipped with a steering damper to hold down its rolling motion. Because tires, too, are important factors to maintain safe and stable high-speed running and because cornering performance depends on whether tires are of good or bad quality, the CB750 employs those specially developed jointly by the Honda and the Dunlop Rubber Co. This rear tires are called, "K87" and its right and left are completely symmetrical. For unsymmetrical rear tires will not be practical because it tends to cause the machine violently oscillate during high-speed running. Cross section of the tire is shaped like a "omusubi" (rice-ball, nearly oval-shaped), roughly the same shape as that of a motorcycle racer's tire.

As this shape of the cross section enables a wider area of the tire touch the ground during cornering, it, too, contributes to make the machine more stable. Also, thick appearance of the tire itself gives big sense of security to a rider. Further, good performance of a brake is essential for the safety of a high-speed machine. It is necessary, therefore, to have a brake that fully meets requirements during a high-speed operation. In this sense, the brake adopted for the CB750 should be said more than enough in meeting the requirements. First of all, the disk brake is compact. Its performance will not deteriorate due to the fade phenomenon because the disk surface is always exposed to the air stream and radiates heat much readily. Lastly, the drum brake is affected little by water. All these features serve to remedy defects of a brake of the drum type: Deterioration of braking performance due to the fade phenomenon caused by overheat of the drum and also extremely bad working of the brake when water gets inside the drum. Needless to say, a high-performance car nowadays tries its best to remove those defects by the use of an improved brake of the drum type, which is equipped with a ventilation hole and a device to stop inflow of water. But all is not good with the disk brake. For it lacks a self-servo control and needs a great force when it works. In the CB750, therefore, its brake works in an oil-pressure system just like that of a car. In this system, braking can be performed without the aid of a large force. And although in practice, the brake of a high-performance car is tasked much harder than generally imagined, the front disk brake of the Tokiko-made single calliper of 296mm diameter looks very durable enough to bear such a hard task and gives a rider confidence in its

durability just in the case of the K87 rear tire. Before the CB750, motorcycles, even high-performance ones, made in Japan usually have been equipped with a headlight that has a power of 35w at most. The CB750, however, is equipped with one of a large shield beam type, that possesses a power of 50w. This large power secures a much safer high-speed motion during the night time. Also, a speed-meter and a tachometer of the separate type placed on the headlight are so designed as to face the rider squarely for easy and quick reading. Also, care is taken for a rider not to irritate his eyes with unnecessary reflecting light by painting upper bracket and the installation portion of handle bar in matted black. Further, a special kill-switch is attached to cut flow of ignition current and stop engine in time of emergency. A large gasoline tank containing 19ℓ oil is mounted indirectly onto the frame with soft rubber cushion in between not to harass the rider with undue vibration.

There are still many other safe-driving devices to be mentioned and it should be said that safety considerations for this machine is almost complete. Maximum speed, 200km/h; acceleration time in S.S. 1/4 mile, 12.4sec and maximum power, 67ps/8,000r.p.m. Judging from these spectacular figures, one may imagine extraordinary huge machine. But actually the CB750 is an easy to ride machine for everyone, although equipped with frame and suspension more high-performance than engine. Besides, its safety devices may be regarded as the best of their kind attained at present throughout the world. The CB750, therefore, should be said as the most high-performance and extremely refined motorcycle assured with almost full-proof safety in the whole world but absolutely not a "Vicious horse".

Essential Specifications

Overall length: 2,160mm Overall height: 1,120mm

Width: 855mm Wheel-base: 1,455mm

Weight: 202kg

Engine: A parallel, 4-cylinder SOHC

Engine capacity: 736c.c

Maximum power: 67PS/8,000rpm

Maximum torque: 6.1kgm/7,000rpm

Maximum speed: 200km/h (depending on running conditions)

Acceleration time in S.S. 1/4 mile: 12.4seconds

Transmission: 5-speed one specially made by the Honda

Brake: Front one, a Girling-patented, Tokiko-made 296mm-diameter single calliper disk brake. Operated by oil-pressure mechanism.

Rear one, a leading-trailing brake worked by mechanical system

Suspension: Front one, telescopic type

Rear one, a swing arm type.

Frame: A double-cradle type

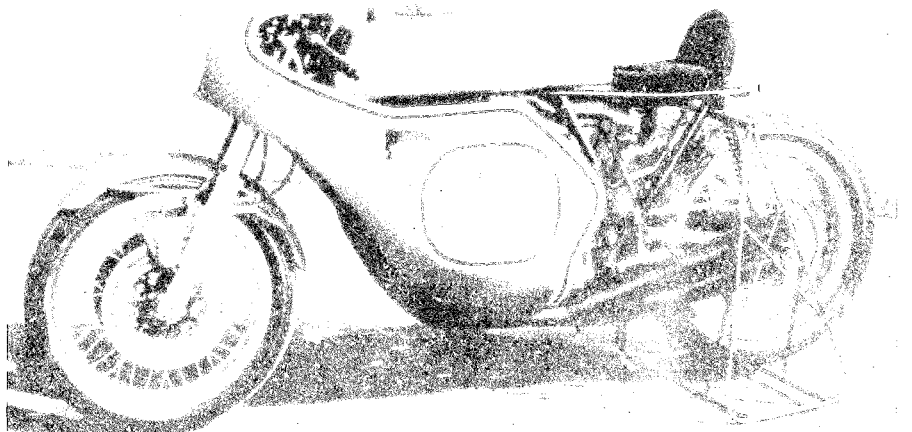

CB750 Road Racer

★Carefully read instructions before starting assembly.
 ★Modeling knife, screwdrivers and sidecutters are required.
 ★Blue-coloured portions in the following figures indicate that they should either be applied with adhesives, or warmed to fastened.
 ★Refer to parts list on the last page for the colour specified for each parts. Key to fine finish of those parts for which a same colour is specified is to paint them after they have been assembled and glued. The following mark (C) in the figure indicates that the marked parts should be painted. Paint it in the order specified in the figure.
 ★Painting instructions will be found on Page 12 and in parts list on the last page.

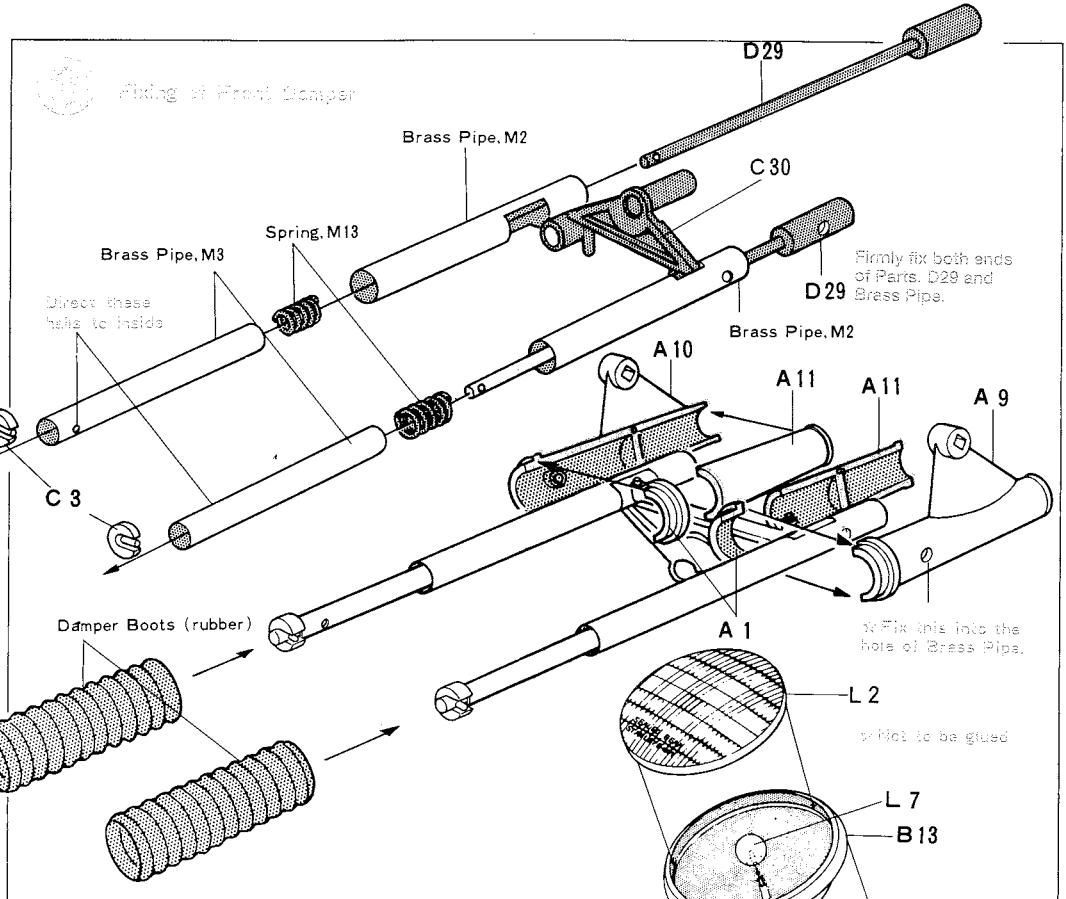
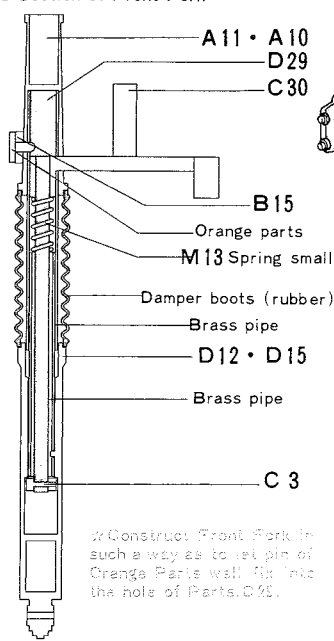

Fig. 1 Fixing of Front Damper
 Place Parts, C30, inside Brass Pipe. Pass Parts, D29, through the whole from above and align the round hole of the D29 with that of Brass Pipe. Fix Brass Pipe into Spring and fasten Damper by fixing Parts, C3, into the lower hole of Parts, D29.
 Next, glue Parts, A9, A10, A11 and A1, in so doing, fix round projections at respective sides of Parts, A9 and A10, into holes of Brass Pipe.

Cross Section of Front Fork



★Construct Front Fork in such a way as to let pin of Orange Parts well fit into the hole of Parts, D12.

Construction of Headlight

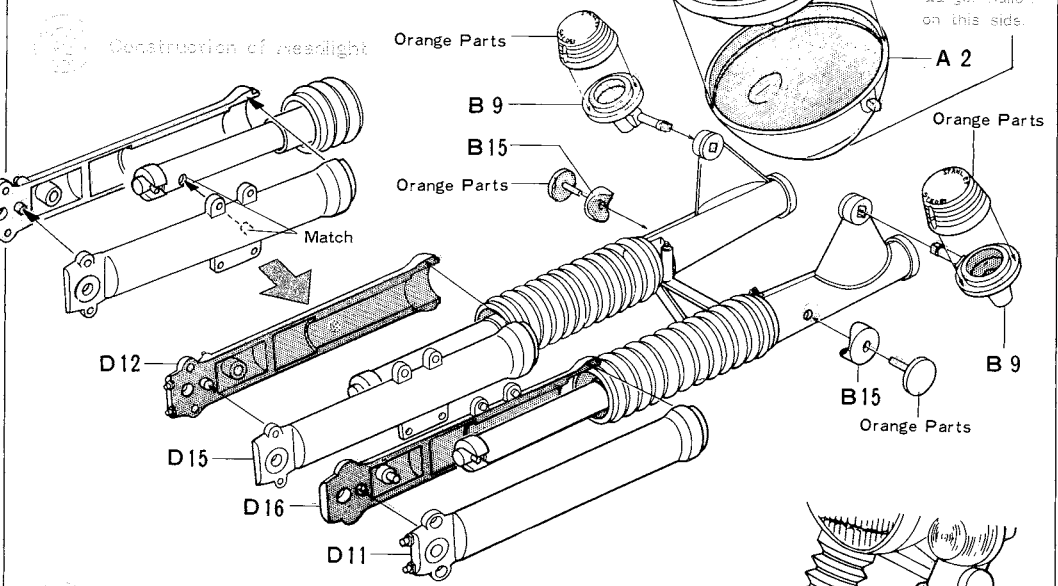

Fixing of Fender

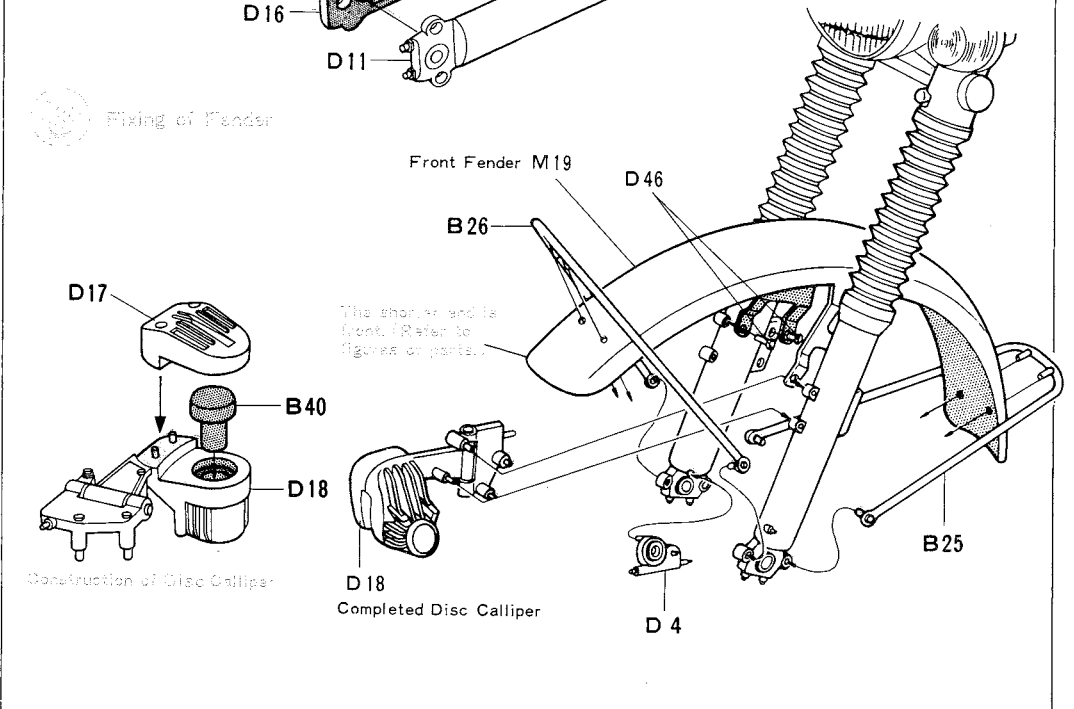

PAINTING

This model of the CB750 is rich in beautiful mechanism. And by good painting you can render its beauty more splendid. Also, painting work itself will be sure to gratify your creative desire fully. Basic painting instructions will be found in each page of this booklet. Refer to them when painting so that you can get a model completely your own.

Construction of Disc Calliper

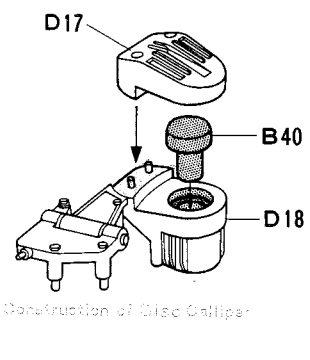

Fig. 4 Construction of Meter
 Firstly, assemble meter parts as illustrated below. Then, put them together as shown to the right.

★Select meter needle (B17) position as you like.

Construction of Tachometer

L 4 (Not to be glued)

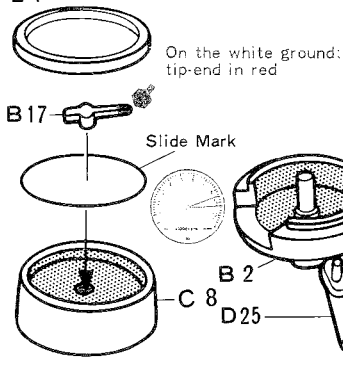

Fig. 5 Construction of Carburetter
 Construct four Carburetters. When fixing Carburetter, take due note of the shape of pin of Parts, D22. Then, glue Air-Cleaner-Case, A6, onto Carburetter.

Construction of Carburetter

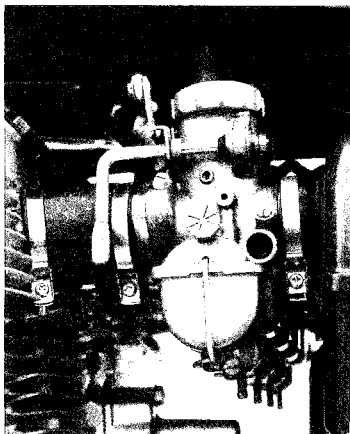
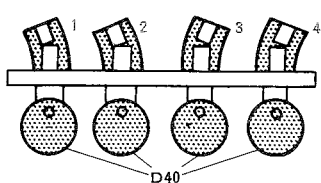
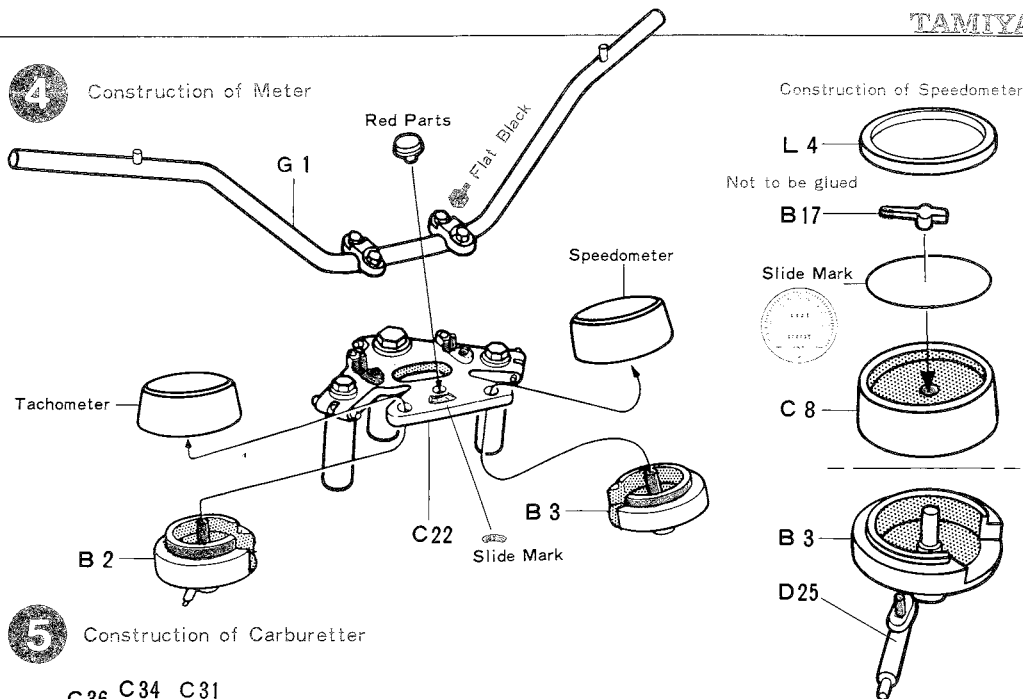
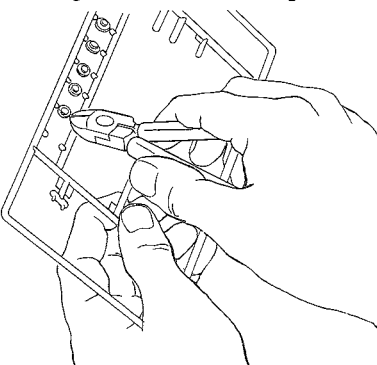

Fig. 6 Construction of Engine, 1
 Glue Parts, E5 and B12, onto Cylinder Head, E6. Next, glue Plug Receptacles, D19, D20 and D28, onto Cylinder Head, E6.

(REMOVING PARTS)

Remove parts by using side cutters or modeling knife. Also remove the gate too.



5 Construction of Carburetter

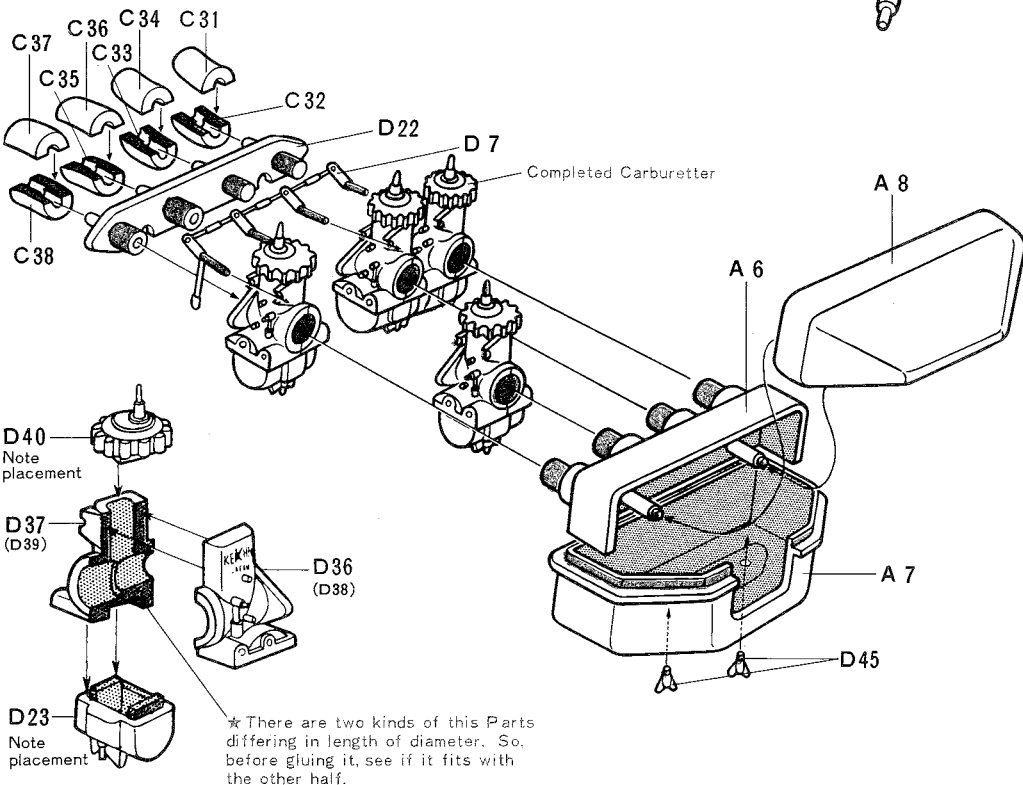

6 Construction of Engine, 1

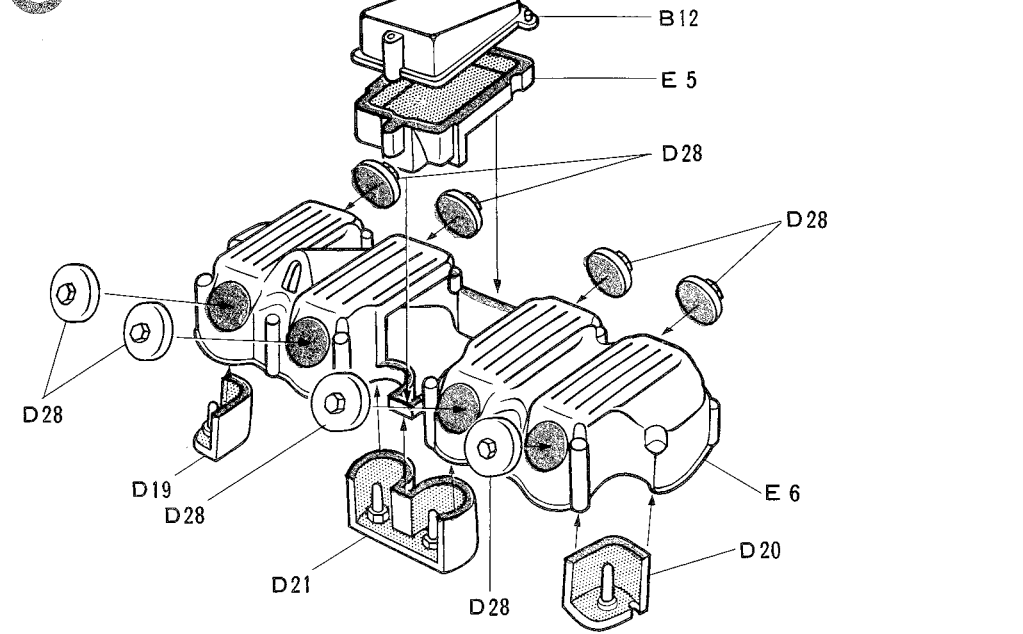

Fig. 7 Construction of Engine 2 Pass Sprocket, B14, through Parts, C28, and secure the whole with Parts, C29. In so doing, be sure not to smear Parts, C28, with adhesives. Then, firstly fix Parts, E12, onto Crankcase, E4. Next, fix the Parts, C28, portion of the completed Sprocket onto the place as indicated in the figure. As for Parts, B18, insert it into the place as shown in the figure after Chain has been constructed. (See Fig. 17.)

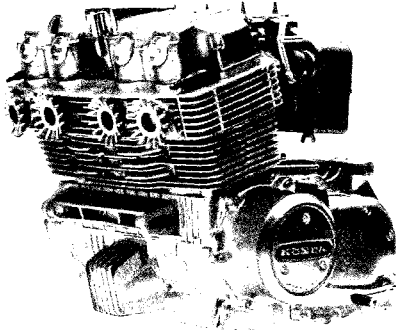

Fig. 8 Construction of Engine 3 Glue Clutchcase, E8, in such a way as to let a thin pin of Parts, B27, pass through the hole in Clutchcase.

- Length of Cords
 Cut the thin black Vinyl Cords
 Clutch cord 23cm
 Speedometer cord 18cm
 Brake cord 17cm
 Throttle cord (a longer one) 12cm
 Tachometer cord 12cm
 Plug cord (two outside ones) 6cm
 Plug cord (two inner ones) 5cm
 Throttle cord (four short ones) 5cm
 Breather cord 5cm
 ★Cut the thick black Vinyl Cord
 Cam Cover Breather Pipe 12.5cm

Fig. 9 Construction of Stand, Fender Snip Stand, C24, with Parts, C14, and glue the whole onto Parts, C4. Fix Spring onto Parts, C12. Then, fix the whole onto the place as shown in the figure. Next, fix respective Parts onto Fender. When gluing Number Plate, paint it first before doing so.

PAINTING

Painting of Engine:
 Engine body proper in a Honda CB750 is made of cast metal. So, the model's one has to look that way. Paint it in silver as if to rub the silver into it. Use the half-dried silver, silver into it.

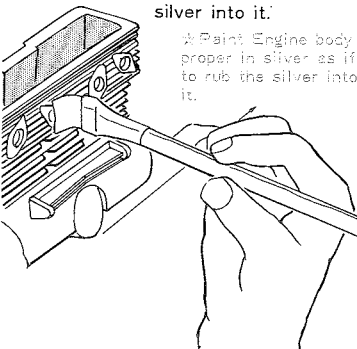

7 Construction of Engine 2

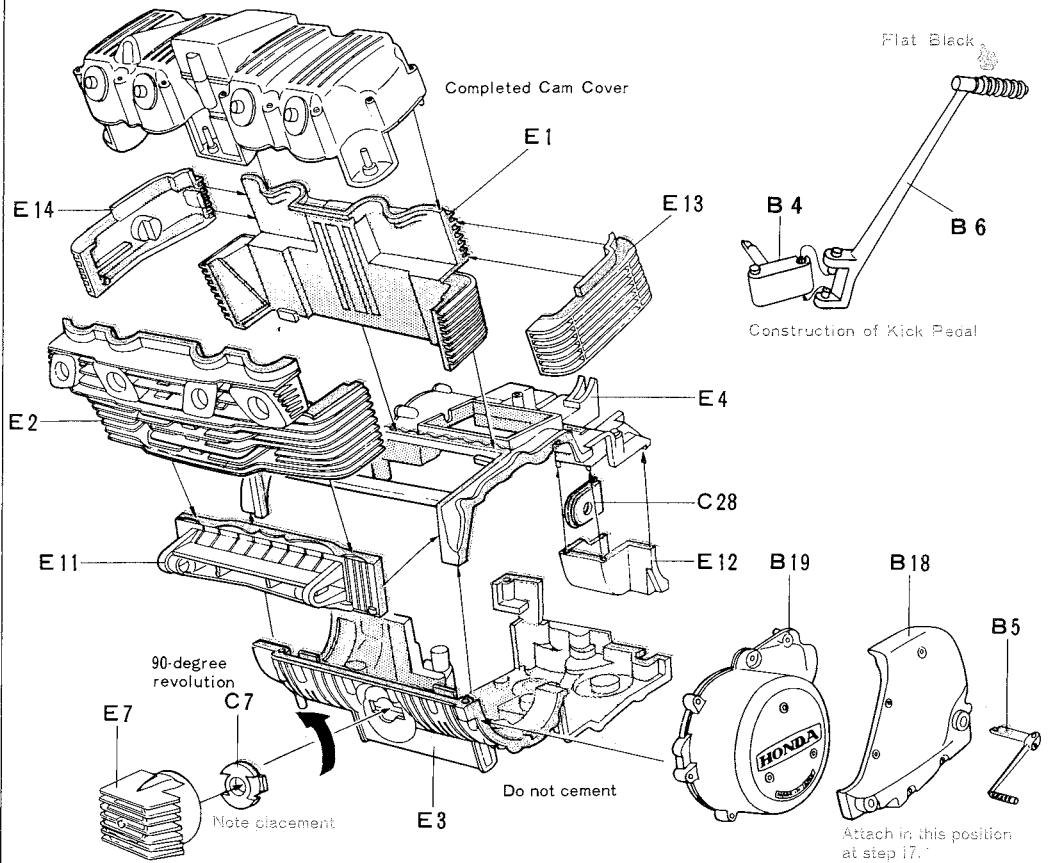

8 Construction of Engine 3

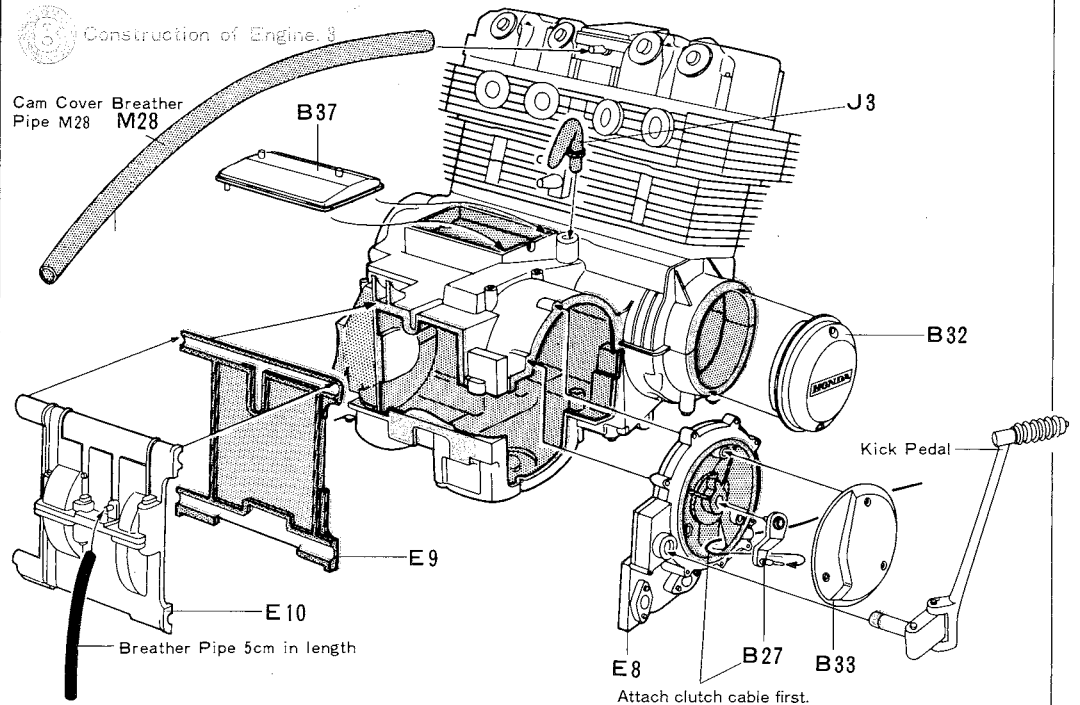

9 Construction of Stand and Fender

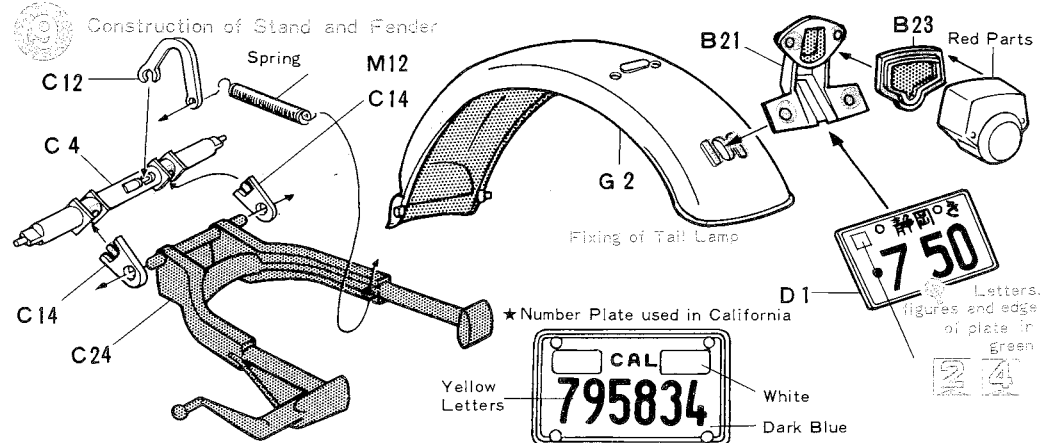
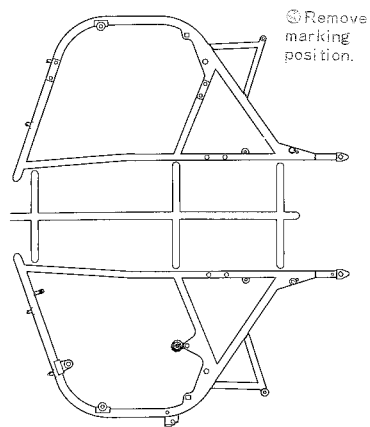

Fig. 10 Construction of Frame



Snip and glue Frame portions, F4 and F5, Fender, G2, Parts, C6, and Stand with Main Frames, F11 and F12. Use a rubber band to glue those parts fully well onto Main Frames.

Fig. 11 Construction of Parts

Firstly, glue Rear Forks, F2 and F3. Then, fix respective Parts. Construct Fuel Tank and apply Decal onto the tank. Lastly, construct Rear Damper and apply Decal onto the Damper.

Cross Section of Rear Damper

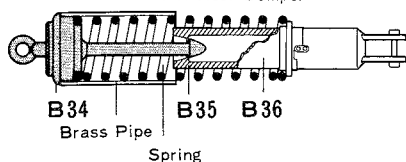

The Picture of A Completed Fuel Tank

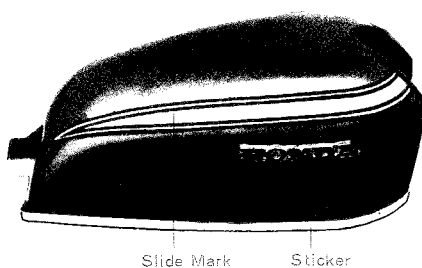

Fig. 12 Construction of Electrical Parts

Attach D8 and D42 on battery case with instant cement. Then attach C13 and D14.

PAINING

Painting of Frame:

Paint the black parts in black. Do it scrupulously a half at a time so that no portion will be left unpainted.

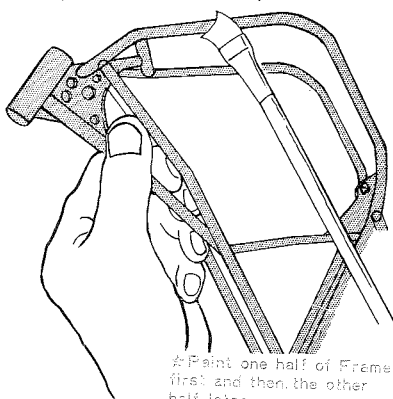

10 Construction of Frame

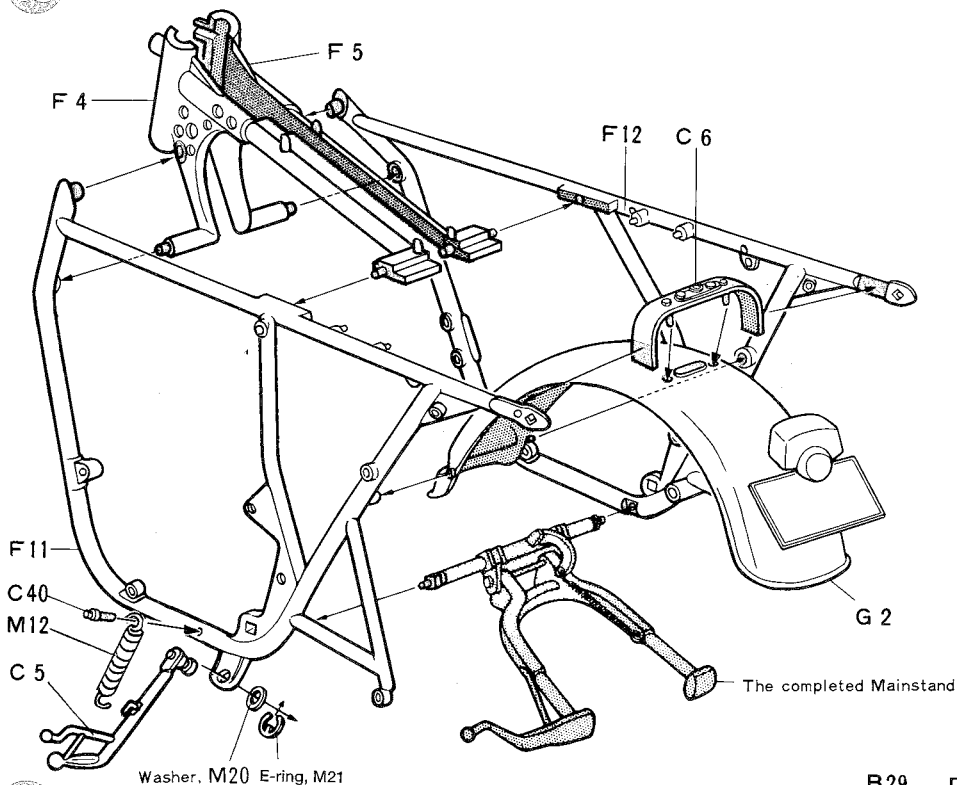

11 Construction of Parts

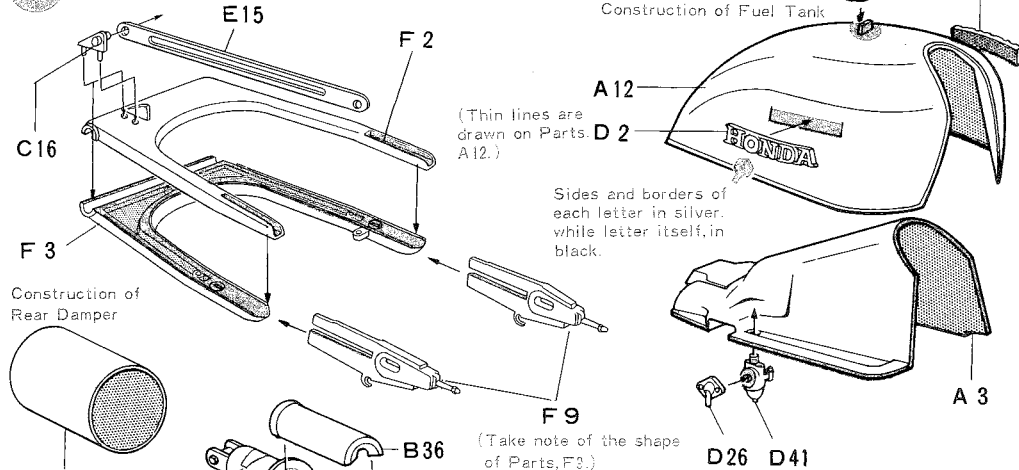

12 Construction of Electrical Parts

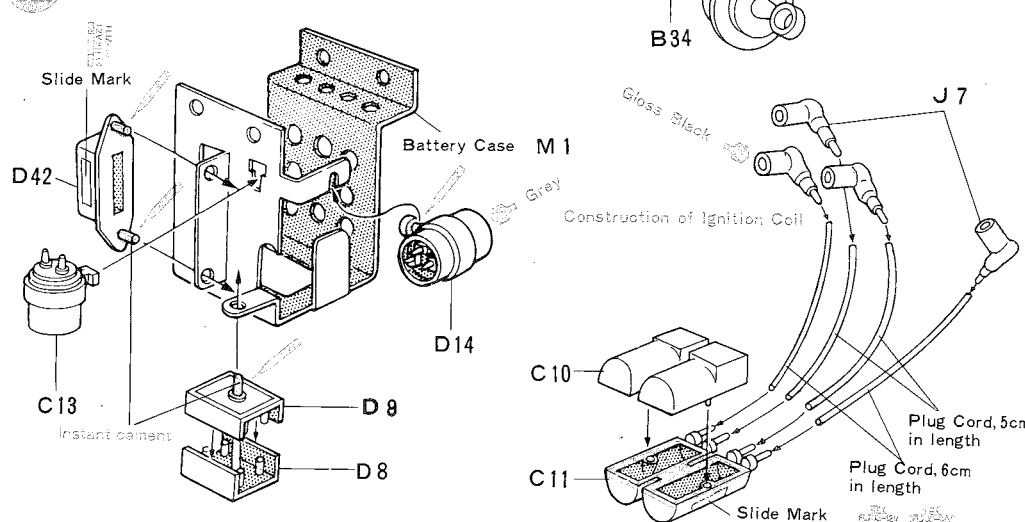
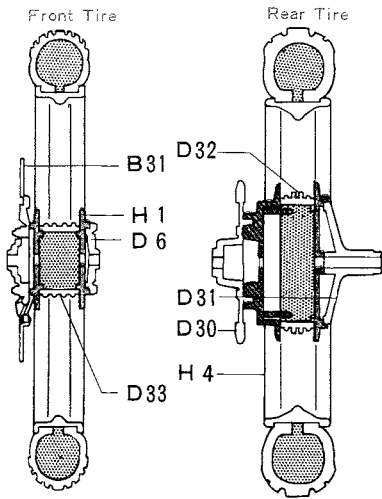
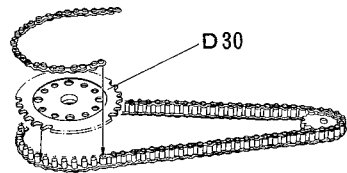

Fig. 13 Construction of Wheel

Construct Wheel, referring to the figure right. Don't glue Brass Pipe and Parts, D31. Paint letters on Tire in white.



(Construction of Chain)



(Construction of Brake Pedal)

As for Brake Pedal, B28, pass it through Frame and then fasten its spring with Frame and Parts, C39, as shown in the figure

Construction of Brake Pedal

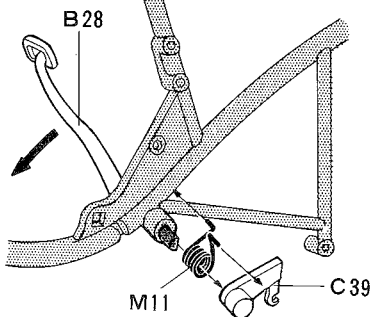

Fig. 15 Construction of Seat

Fix Parts, C2, into Seat, J1. Glue Decal at the backside of Seat. Pile vinyl chloride plates of Battery alternately as shown in the illustration. Then, place the whole inside the case.

PAINTING

Painting of Disk Brake:

Firstly, polish the silver ground with compound. Then, paint Brake Shoeline in chrome silver. In so doing, turn the Disk.

Do an easier painting job by turning the disk around.

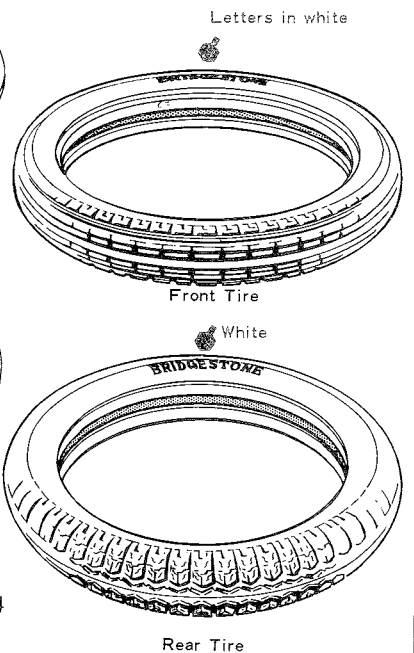
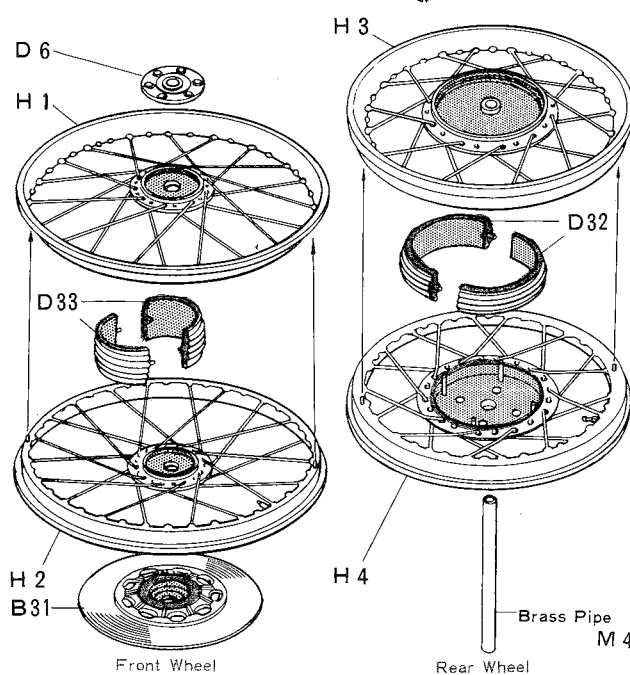
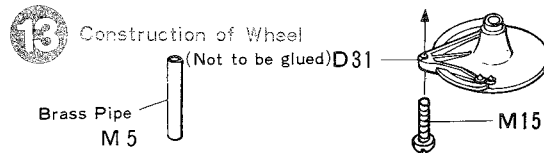
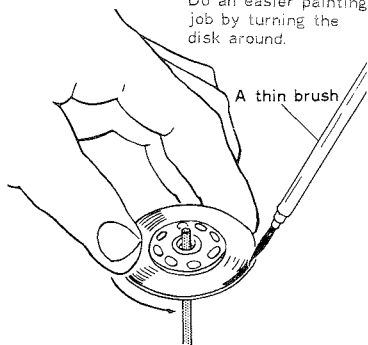

14 Fixing of Parts onto Frame

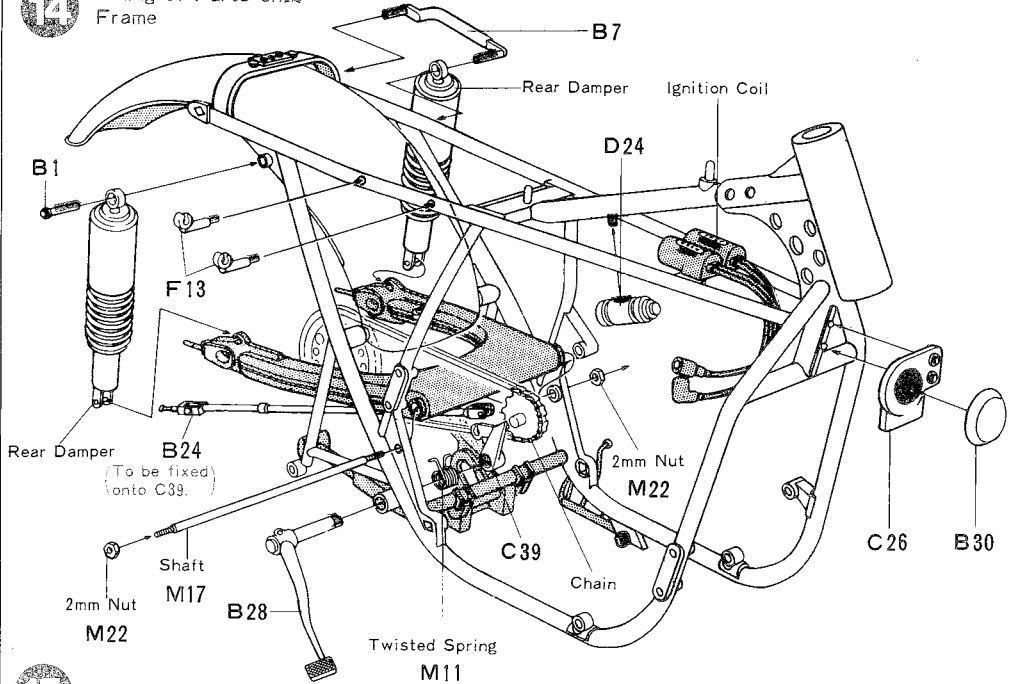

15 Construction of Seat

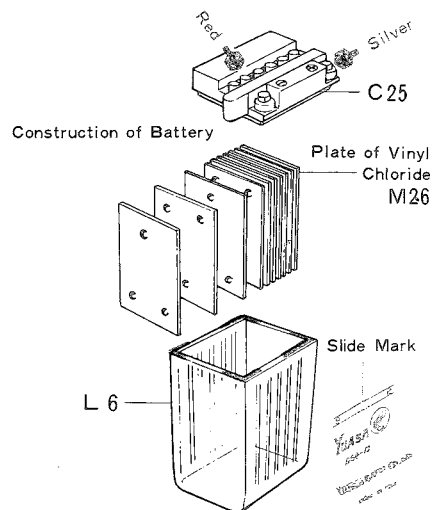
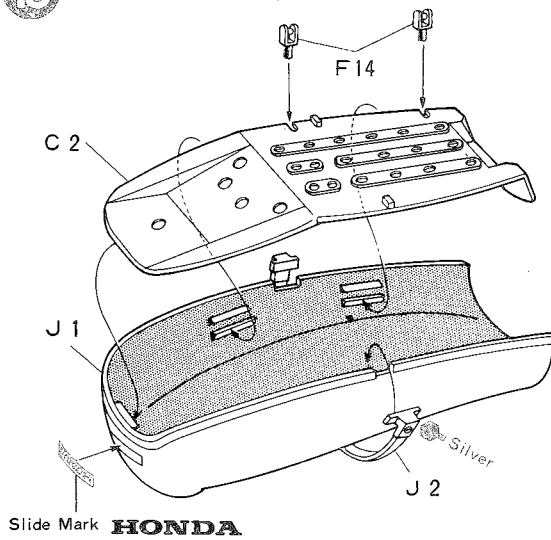
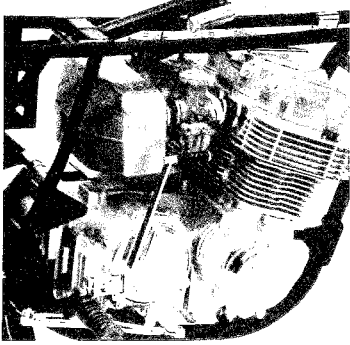

Fig. 16 Mounting of Engine
Mount Engine onto Frame from the latter's right side. Next, fix Carburetter onto Engine and fasten Engine with Stopper Parts.

★After fixing Engine Carburetter onto Engine, hold Engine down with Parts, F8, F10 and F6.

★★If it is desired to have Engine removable later don't glue Stopper Parts, F8, F10 and F6, and Carburetter.



Fixing of Gear Box Cover

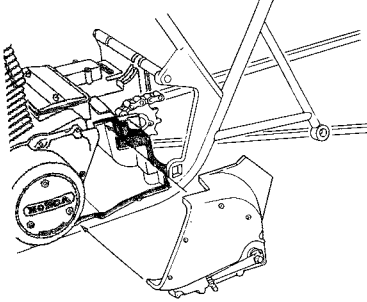
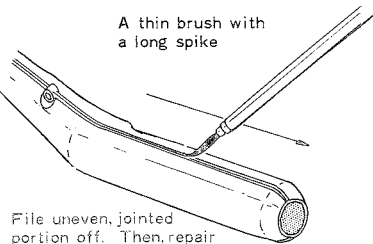

Fig. 18 Construction of Muffler
When constructing Muffler, check the parts number of Muffler Parts.

PAINTING

Repair of Worn-off Plating:

Use chrome silver to repair worn-off plating. In so doing, a thin brush with a long spike is preferred.



16 Mounting of Engine

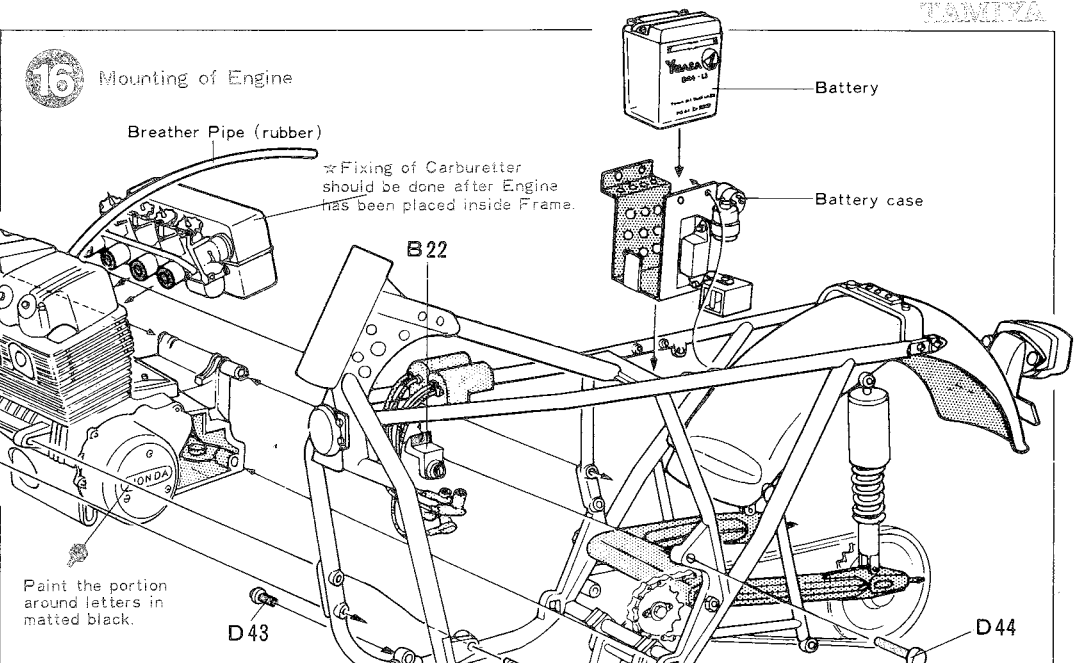

17 Fixing of Tires

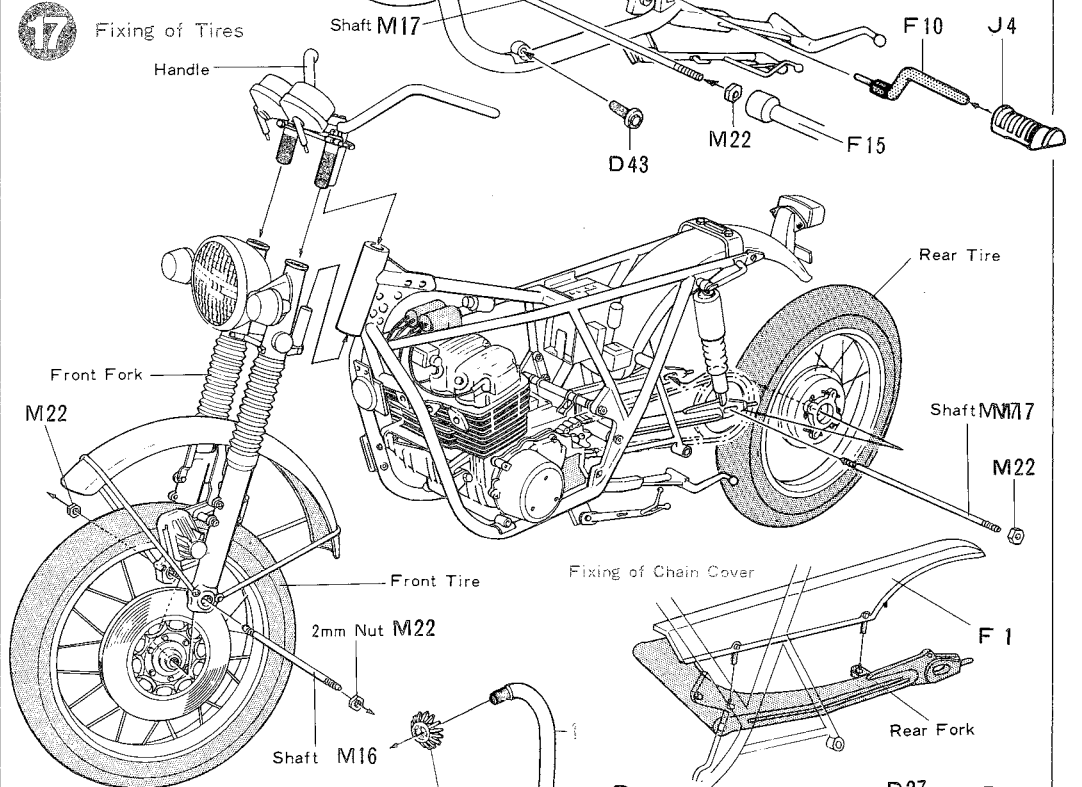

18 Construction of Muffler

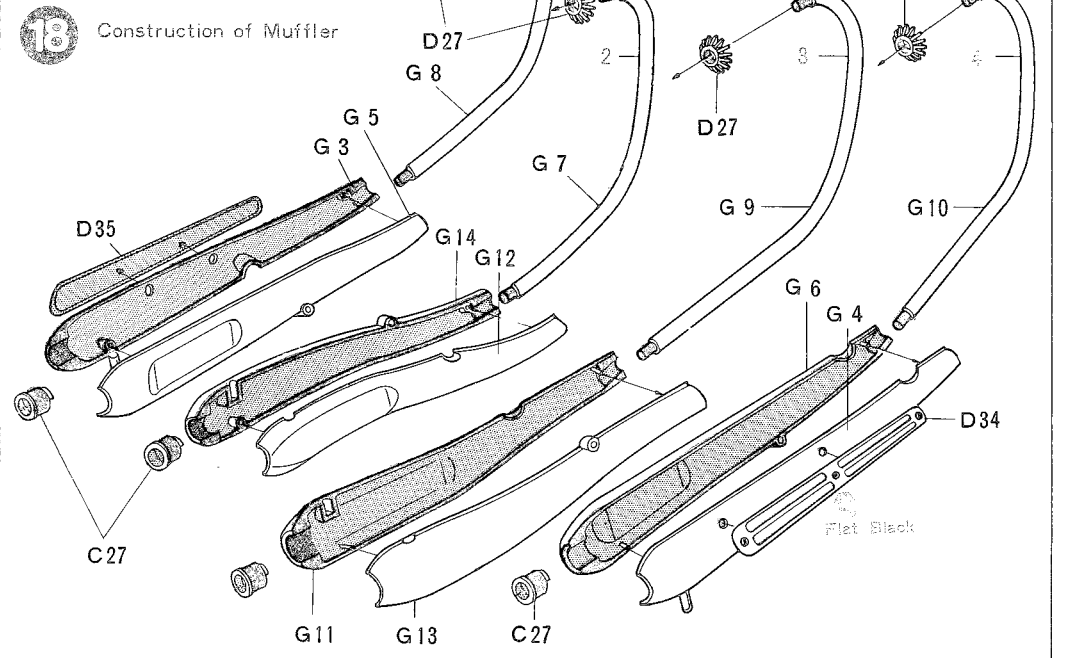

Fig. 19 Fixing of Brake Stopper Arm
 Fix and fasten Brake Stopper Arm onto Parts, D31, with Vis and 2mm Nut. Fix the completed Oil Tank, referring to the cut of Fig. 23.
 (Construction of Handle Parts)
 Firstly, pass Axle Grip, J5 and then construct Clutch and Brake. For Lever angle, refer to the picture on the parcel box. Then, glue Lever. Distribute Cords of Clutch and Speedometer respectively. (Black lines in the figure represent respective Cords.

Construction of Brake Stopper Arm

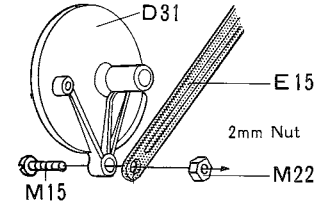
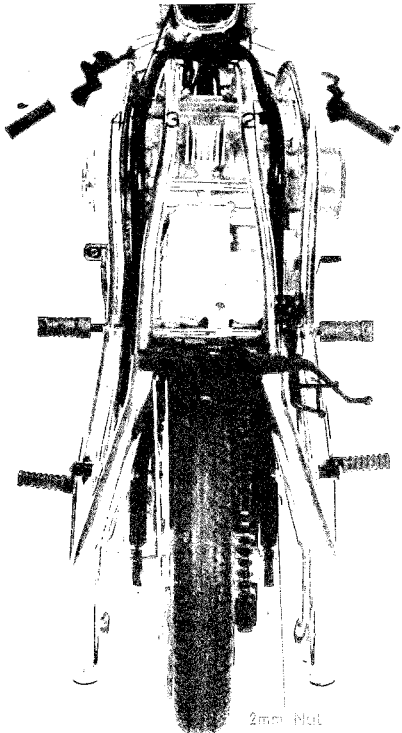
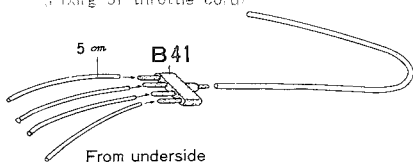

Fig. 20 Fixing of Muffler

Insert Spring from Oil Tank into the place as indicated in the figure, and then, distribute each Cord. Next, fix and fasten Muffler with screw onto the place as shown in the figure and at the rear portion of Frame.

The Picture below shows Muffler fixed (Fixing of throttle cord)



PAINTING

Painting of Bolts:
 Those Bolts which are used in Frame and Engine should be painted in chrome silver. These Bolts serve to accent the whole effect. So, that paint them as scrupulously as possible.

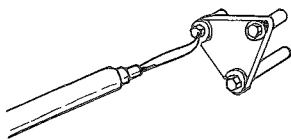

19 Fixing of Brake Stopper Arm

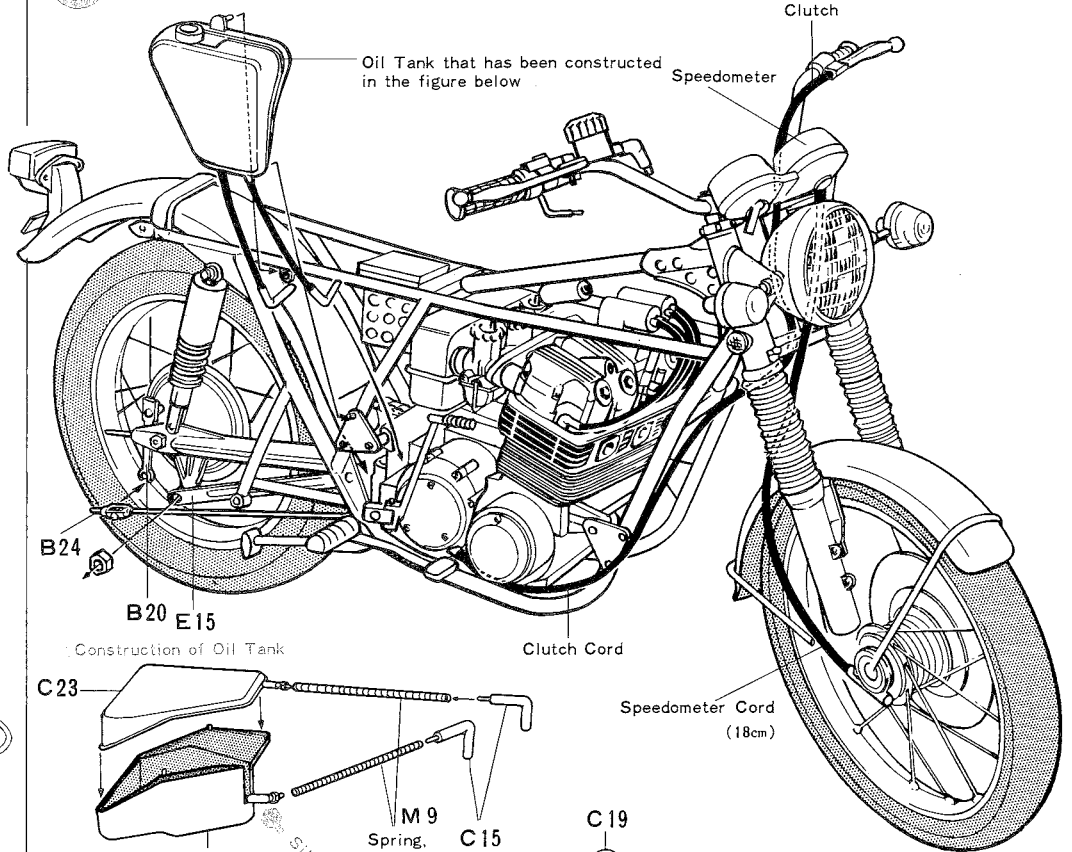

Construction of Oil Tank

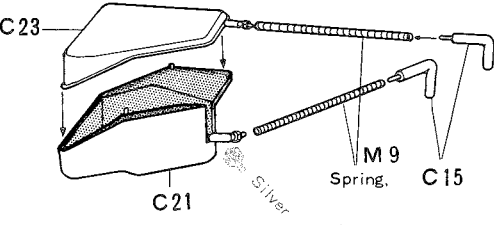

Construction of Handle Parts

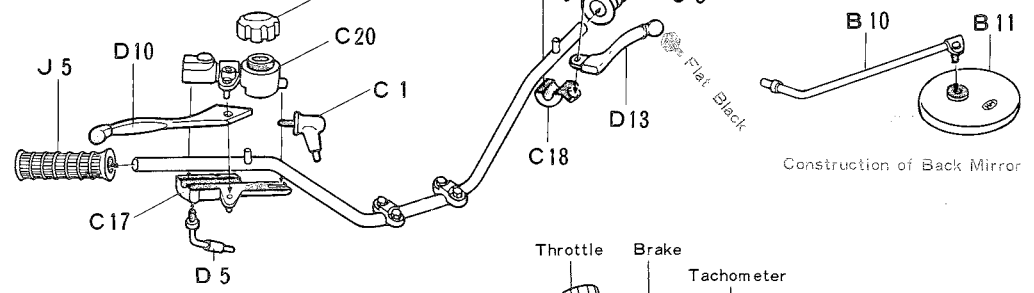

20 Fixing of Muffler

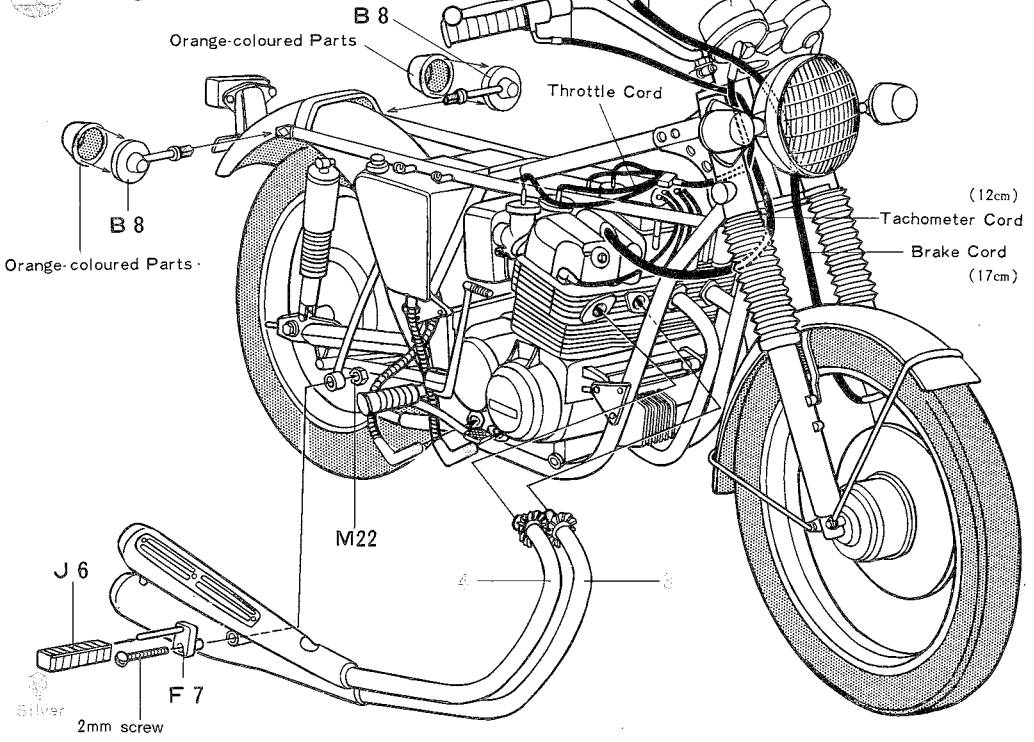

Fig. 21 Fixing of Fuel Tank
Don't glue but just put Fuel Tank,
Side Cover, and Seat onto the frame.

(Fixing of Back Mirror)

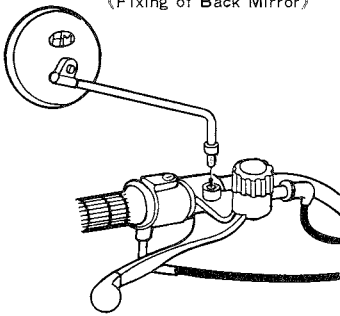
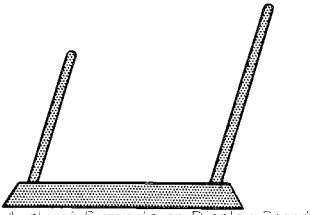

Fig. 22 Display of Engine
Construct Display Stand and display
Engine on the stand as shown in the photo.



Angle of Supports on Display Stand

PAINTING

Finish of the Whole:
After decals have been glued and dried up, apply wax onto the whole to polish.
In so doing, use a soft cloth with a little bit of wax.
Even plating parts will be finished so beautifully that it will look completely different.

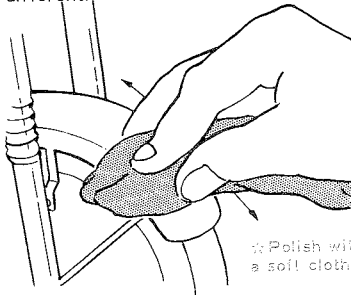

Polish with a soft cloth.

The Picture of a Completed Model

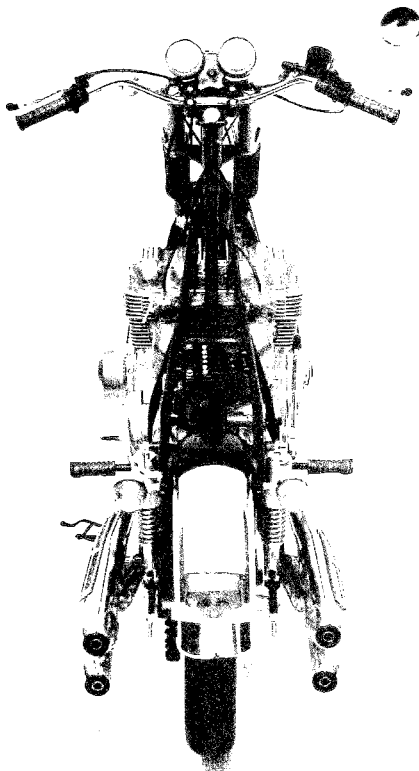
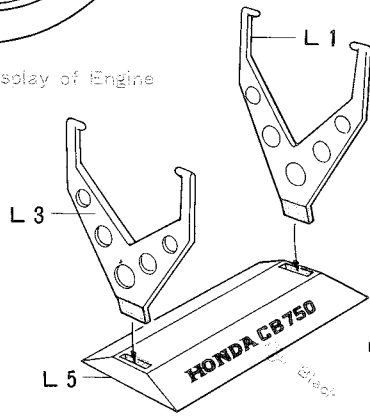
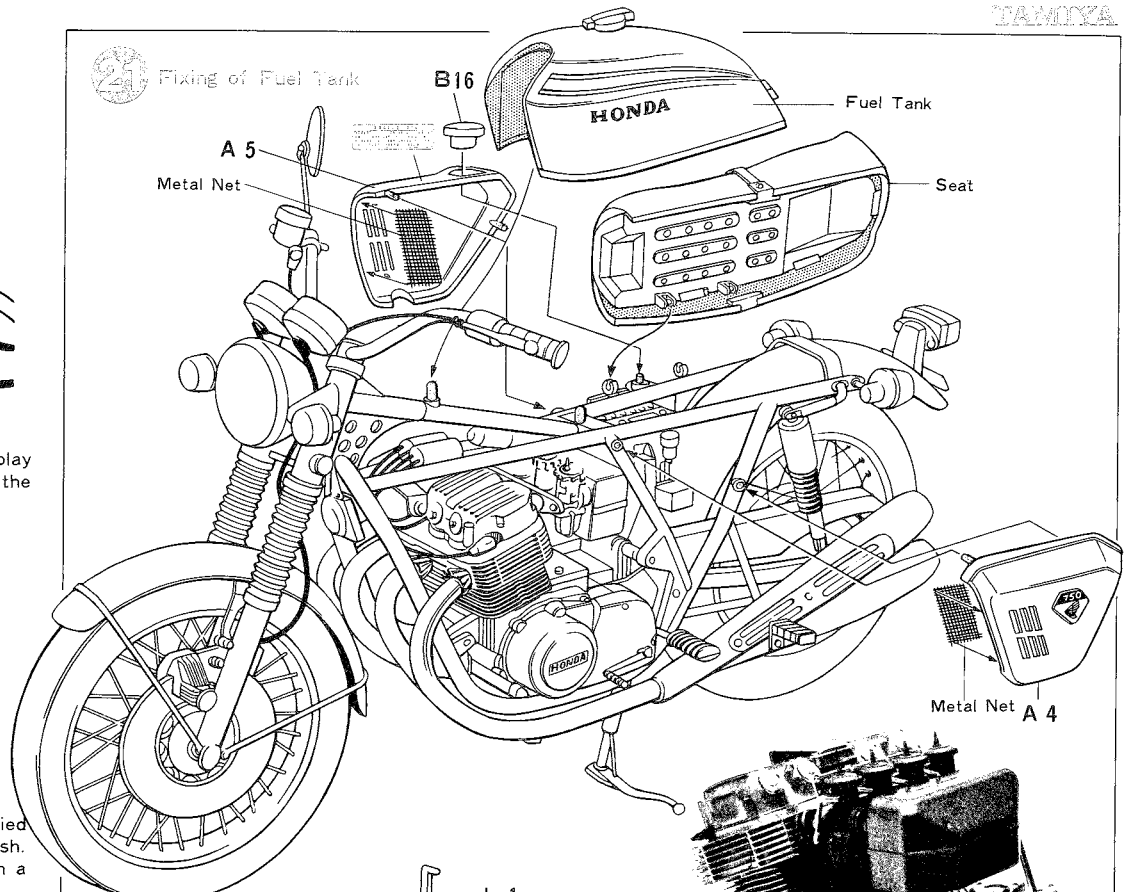
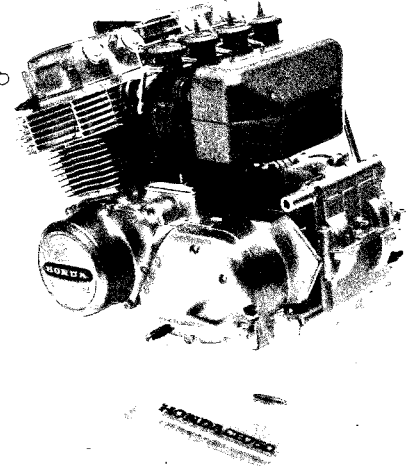

Fig. 23 Display of Engine



Displaying engine.



PAINTING APPLYING DECALS

Painting:
Painting is done not only to change the colour of each parts. It is done so that shape and function of a particular parts will be made all the more clear.
Seven colours in all are to be used to increase a massive feeling of the model. Name of each colour will be found in right side of this page.

Before Painting:
Parts:
Before painting, clean out any dusts and oils from the surface of each part with soft cloth. Wash out with detergent if needed. Those portions of parts on which cement has been overflowed can not be concealed by paint. After cement has dried, remove overflows with modeling knife and file to realize smooth surface.
Irregular parting-line (place of joint between parts, or metals), too, should be corrected by filing.
Key to fine finishing of parts is to paint them after they have been assembled in their places. Parts of a same colour should be painted together as far as possible after they have been glued and their uneven jointed places, made fully even.

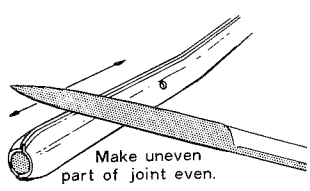

Needless to say, those parts which could not be reached by a painting brush once they have been constructed, should be painted before construction.

Painting tools:
Get a brush, a dissolving dish and a waste ready. For a painting brush, use one for design work. Use two kinds of brushes: A flat one and a thin one. And both should be of soft hairs and with long spikes.
For a dissolving dish, use either a china dish or a transparent prepackage in which the model parts has been contained. Or again, a palette bought at a paint shop will do.



After painting, remove paints off brushes with lacquer thinner and then wash them with water. Keep the cleansed brushes in good state for future use.

Paints and Solvents
There two kinds of paints for the plastics — the alcohol-induced ones and the enamel paints. For the former type, methyl-alcohol and for the latter, turpentine respectively can be used in place of thinner. So, get them at a pharmacy or a paint shop. Even in case of a same

colour, each kind of paints could represent a colour feeling distinctly its own. Use either of them, therefore, to get a colour feeling best suited for the occasion.



For brush cleansing, cheap lacquer thinner will be used. However, in using it, take care that lacquer thinner won't dissolve the plastics. Also, take full caution when using paints and solvents as they catch fires easily.

Colours of Paints to be Used

Black:
Glossy black, common to both kinds of paints.

Flat black:
Flat black, common to both kinds of paints.

Chrome silver:
Bright silver colour.
Glittering silver peculiar to an enamel one.

(Body colour:)
In a Honda CB750 model, metallic colours should be used.

(Other colours:)
Seven colours in all are used to paint the whole of the model. Also, some other colours like red, white and grey will be used to accent the painting effect.
See further colour photogravures of the original motorcycle or pictures in catalogue to produce a much better feeling of actuality by painting.

Silver:
Common silver of the alcohol-type without gloss.

Chrome plating:
Plastic plating parts themselves. In repair, use chrome silver.

Gun Metal:
Used for painting chain.
Express metal place with black leather.

Applying Decals
Where to apply decals are indicated in the two-view plan below. However, each precise spot to be applied with a decal will be found in each figure for construction. See it for precise work.

- ① A decal to be applied should be cut off beforehand.
- ② Dip it in water. When the ground paper it is on arches, get the whole out of water to place on a cloth such as a towel.
- ③ A minute or two later, hold edge of the ground paper to slide the decal onto the model from the ground paper.
- ④ Then, get a little of water on your finger to wet the decal so that the latter will be moved more easily onto the right spot.
- ⑤ Press the decal down with a soft cloth such as a towel to force air bubbles out of underside of the decal. Continue the work until the excess water, too, will be fully absorbed. When the surface to be applied with a decal is uneven or curved, press the decal down with a steamed towel so that the warmed, wet decal will fit the surface well. Cut off the excess transparent portion around a decal before applying. When so done, you can expect a sharp finish with the decal precisely in its specified place.

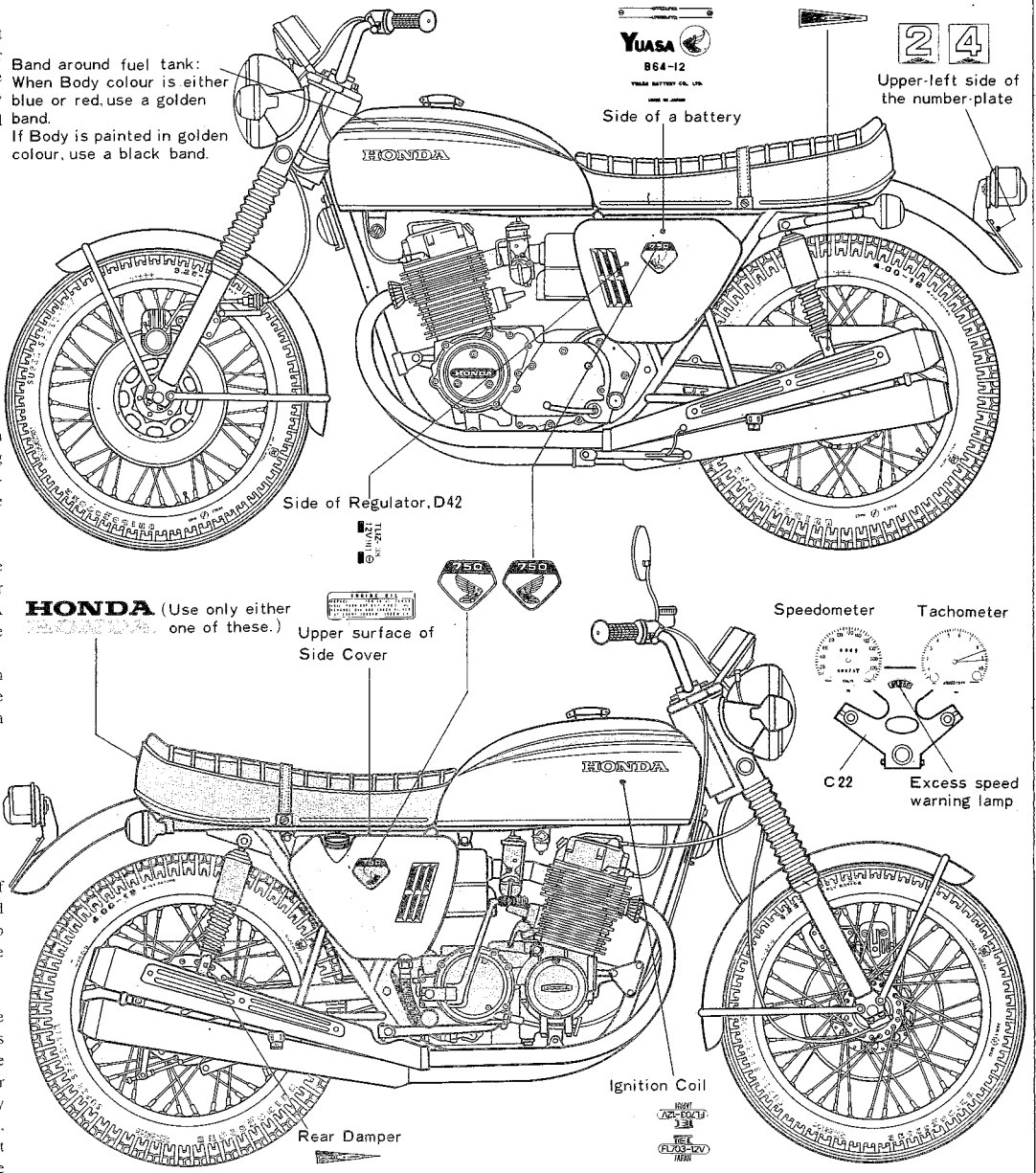

PARTS



PARTS

1. Front Fork Cover C
2. Head Light Case
3. Fuel Tank Under side
4. Battery Cover
5. Oil Tank Cover
6. Air Cleaner Case C
7. Air Cleaner Case B
8. Air Cleaner Case A
9. Front Fork Cover Left A
10. Front Fork Cover Right A
11. Front Fork Cover B
12. Fuel Tank



PARTS

1. Damper Stopper
2. Tachometer
3. Speedometer
4. Kick Starter Joint
5. Gear Change Pedal
6. Kick Starter Arm
7. Side Grip
8. Front Flasher Lamp Base
9. Rear Flasher Lamp Base
10. Back Mirror Stay
11. Back Mirror
12. Head Breather Cover
13. Head Light Sealed Beam
14. Drive Sprocket
15. Reflector Parts
16. Oil Tank Cap
17. Meter Needle
18. Transmission Cover
19. Dynamo Cover
20. Rear Brake Arm
21. Number Plate Bracket
22. Combination Switch
23. Tail Light Base
24. Rear Brake Rod
25. Front Fender Stay A
26. Front Fender Stay B
27. Clutch Parts
28. Rear Brake Pedal
29. Fuel Tank Cap
30. Horn A
31. Front Disc
32. Point Cover
33. Clutch Adjuster Cover
34. Damper A
35. Damper B
36. Damper C
37. Starting Motor Cover
38. Pipe Holder
40. Brake Pad



PARTS

1. Master Cylinder Boot
2. Seat Under Side
3. Front Damper Stopper
4. Main Stand Parts A
5. Side Stand
6. Frame Parts
7. Oil Filter Parts
8. Meter Case
9. Oil Cup Cap
10. Ignition Coil B
11. Ignition Coil A
12. Return Spring Hook
13. Starter Magnetic Switch
14. Main Stand Parts B
15. Oil Pipe Joint
16. Brake Stopper Receiver
17. Master Cylinder Body B
18. Clutch Lever Parts B
19. Clutch Lever Parts A
20. Master Cylinder Body A
21. Oil Tank B
22. Fork Top Bridge
23. Oil Tank A
24. Main Stand
25. Battery Top
26. Horn B
27. Muffler Parts
28. Drive Sprocket Receiver
29. Driver Sprocket Stopper
30. Steering Stem
31. Insulator 4A
32. Insulator 4B
33. Insulator 3A
34. Insulator 3B
35. Insulator 2A
36. Insulator 2B
37. Insulator 1A
38. Insulator 1B
39. Brake Crank Arm
40. Spring Stopper

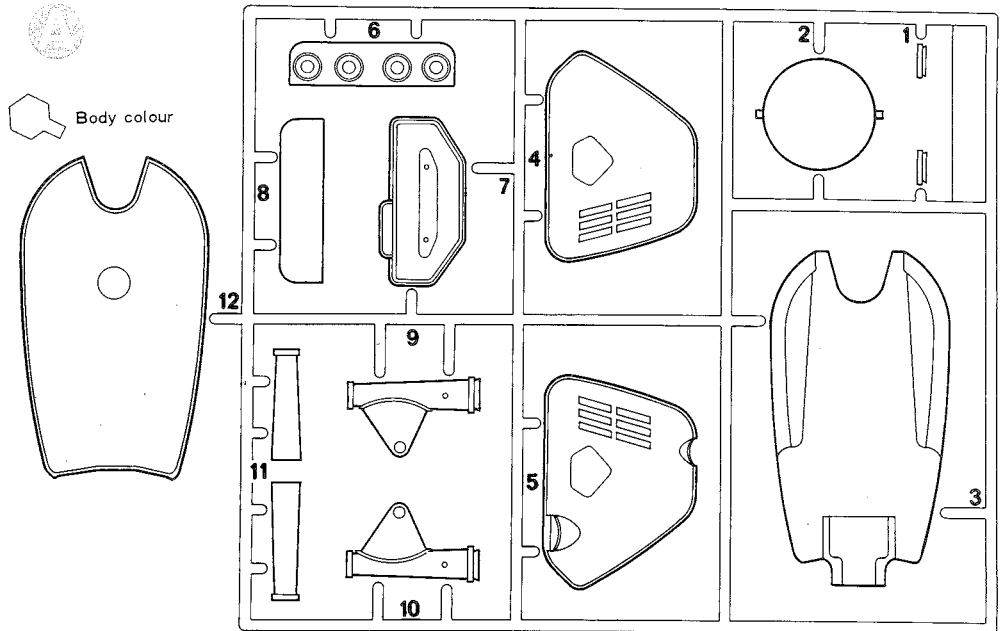

Metal plated Black Flat black

This is not needed.

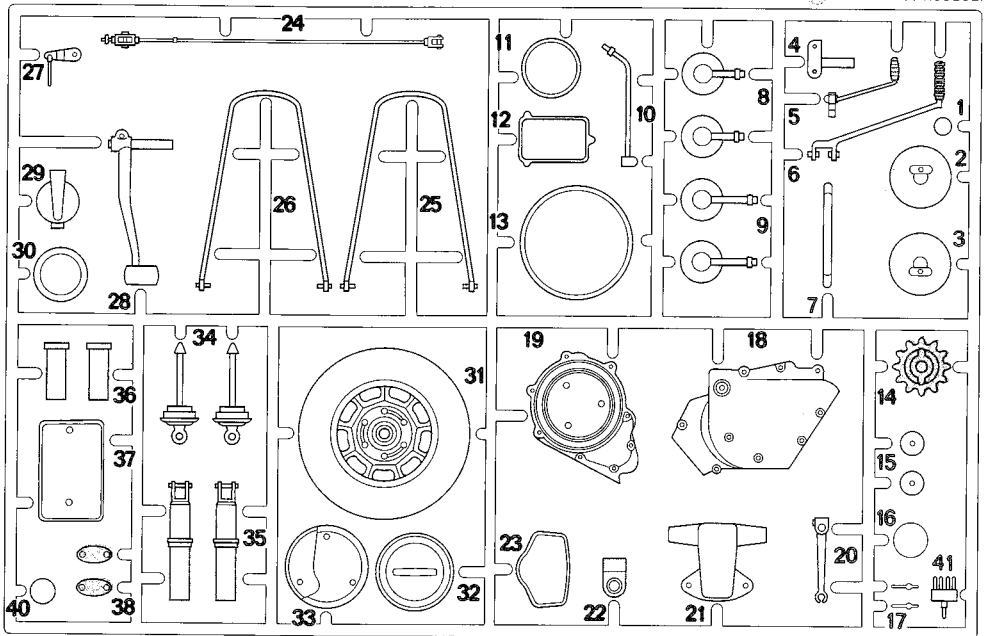

Gloss Black Flat Black

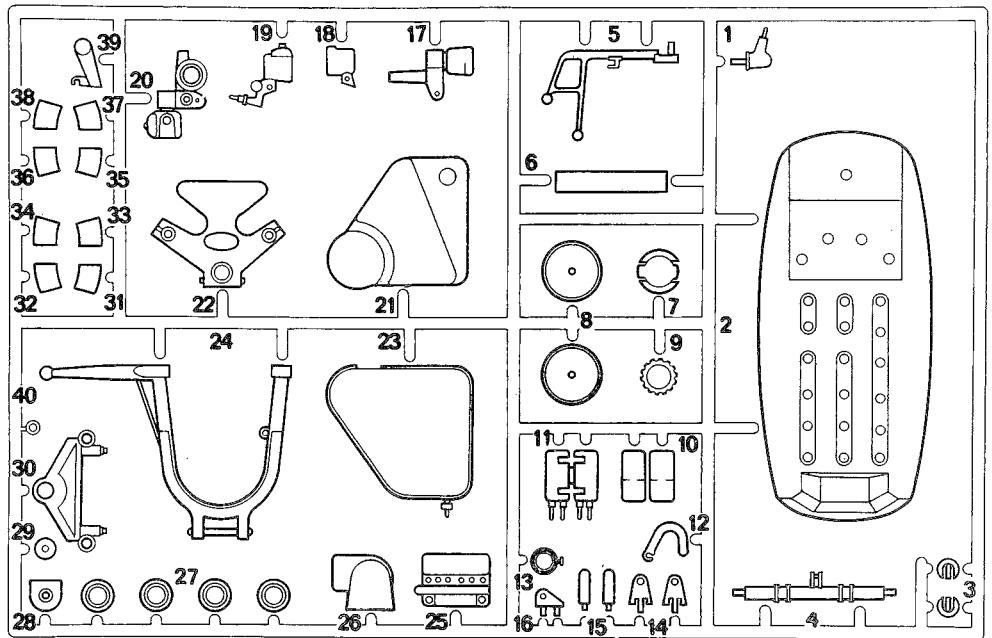

PARTS

E PARTS

1. Cylinder Front Side
2. Cylinder Back Side
3. Lower Crank Case
4. Upper Crank Case
5. Cylinder Head B
6. Cylinder Head A
7. Oil Filter
8. Clutch Case
9. Crank Case Back Side A
10. Crank Case Back Side B
11. Crank Case Front Side
12. Lower Crank Case Parts
13. Cylinder Left
14. Cylinder Right
15. Brake Stopper Arm

D PARTS

1. Number Plate
2. Emblem Right
3. Emblem Left
4. Speedometer Gear Box
5. Throttle Cable Joint A
6. Front Wheel Parts
7. Choke Lever
8. Rectifier
9. Rectifier
10. Brake Lever
11. Front Fork Bottom Case Left A
12. Front Fork Bottom Case Right A
13. Clutch Lever
14. Flasher Relay
15. Front Fork Bottom Case Right B
16. Front Fork Bottom Case Left B
17. Caliper B
18. Caliper A
19. Engine Parts B
20. Engine Parts C
21. Engine Parts A
22. Stay Plate
23. Carburettor D
24. Condenser
25. Meter Joint
26. Fuel Cock B
27. Exhaust Joint
28. Tappet Adjusting Hole Cap
29. Damper Rod
30. Final Sprocket
31. Rear Brake Panel
32. Rear Brake Drum
33. Front Wheel Hub
34. Muffler Protector Right
35. Muffler Protector Left
36. Carburettor Right B
37. Carburettor Right C
38. Carburettor Left B
39. Carburettor Left C
40. Carburettor A
41. Fuel Cock A
42. Regulator
43. Caliper Mount
44. Engine Mount
45. Air Cleaner Bolt

G PARTS

1. Handle Pipe
2. Rear Fender
3. Muffler Upper Left A
4. Muffler Upper Right A
5. Muffler Upper Left B
6. Muffler Upper Right B
7. Exhaust
8. Exhaust
9. Exhaust
10. Exhaust
11. Muffler Lower Right B
12. Muffler Lower Left B
13. Muffler Lower Right A
14. Muffler Lower Left A

F PARTS

1. Chain Case
2. Rear Fork Lower
3. Rear Fork Upper
4. Frame Left
5. Frame Right
6. Engine Hanger Bracket A
7. Rear Step
8. Engine Hanger Bracket B
9. Rear Fork Parts
10. Step Arm
11. Main Frame Left
12. Main Frame Right
13. Seat hinge A
14. Seat hinge B
15. Wrench A
16. Wrench B



Metal plated (flat)

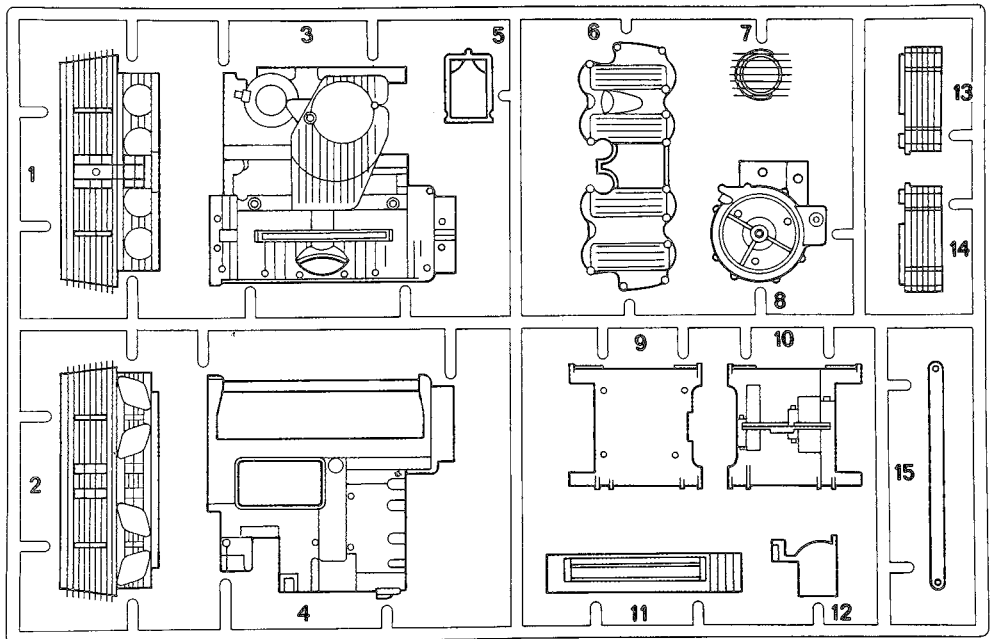

Metal plated (flat)

White

Flat black

This is not needed.

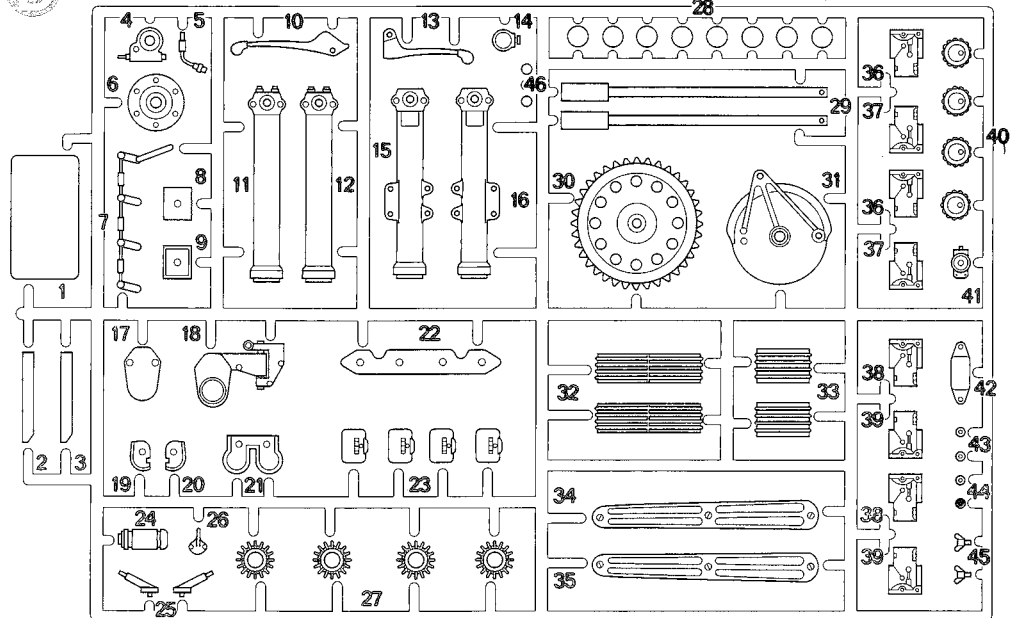

Matted black



Gloss Black

Chrome

Silver

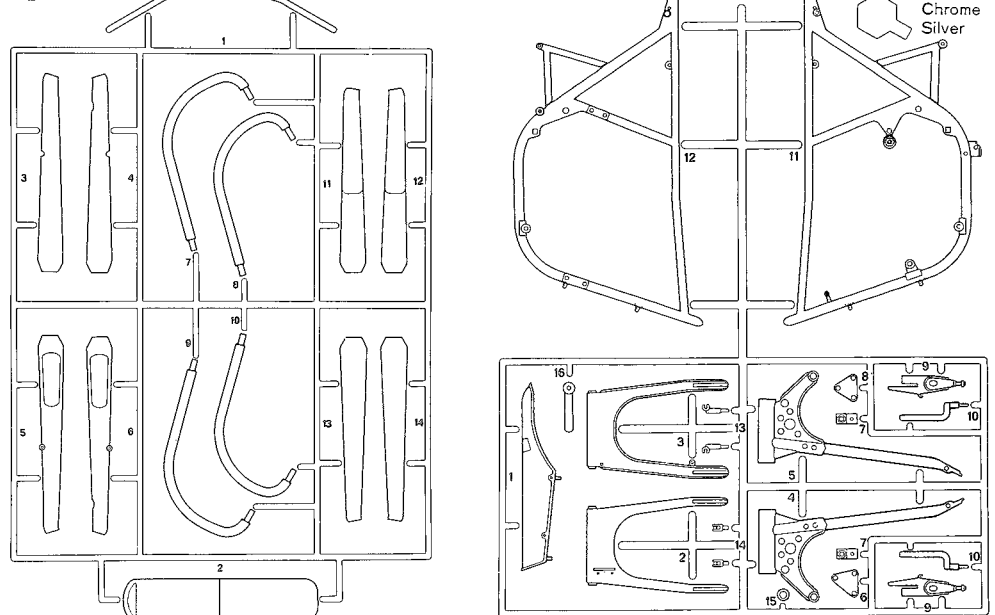

PARTS



PARTS

- 1. Seat
- 2. Seat Belt
- 3. Cord Boot
- 4. Step Rubber
- 5. Accelerator Grip
- 6. Rear Step Rubber
- 7. Spark Plug Socket



PARTS

- 1. Front Wheel
- 2. Front Wheel
- 3. Rear Wheel
- 4. Rear Wheel



PARTS

- 1. Display Stand Stay
- 2. Head Light Lens
- 3. Display Stand Stay
- 4. Meter Glass
- 5. Display Stand
- 6. Battery Case
- 7. Light Bulb



PARTS

- 1. Battery Case
- 2. Brass Pipe (6φ×56mm)
- 3. Brass Pipe (5.3φ×46mm)
- 4. Brass Pipe (3φ×42mm)
- 5. Brass Pipe (3φ×25mm)
- 6. Brass Pipe (10.5φ×17mm)

- 8. Damper Boots (rubber)
- 9. Oil Tank Spring
- 10. Rear Damper Spring
- 11. Twisted Spring for Brake
- 12. Spring for Stand
- 13. Spring for Front Suspension
- 14. 2mm Vis (20mm below neck)
- 15. 2mm Vis (6mm below neck)
- 16. Front Shaft
- 17. Rear Shaft
- 18. Shaft for Rear Fork
- 19. Fender
- 20. 6φ Washer
- 21. E-shaped Ring
- 22. 2mm Nut
- 23. Chain
- 25. Metal Net
- 26. Plate of Vinyl Chloride
- 27. Black Vinyl Pipe
- 28. Black Vinyl Pipe
- 29. Driver
- 30. Driver adapter

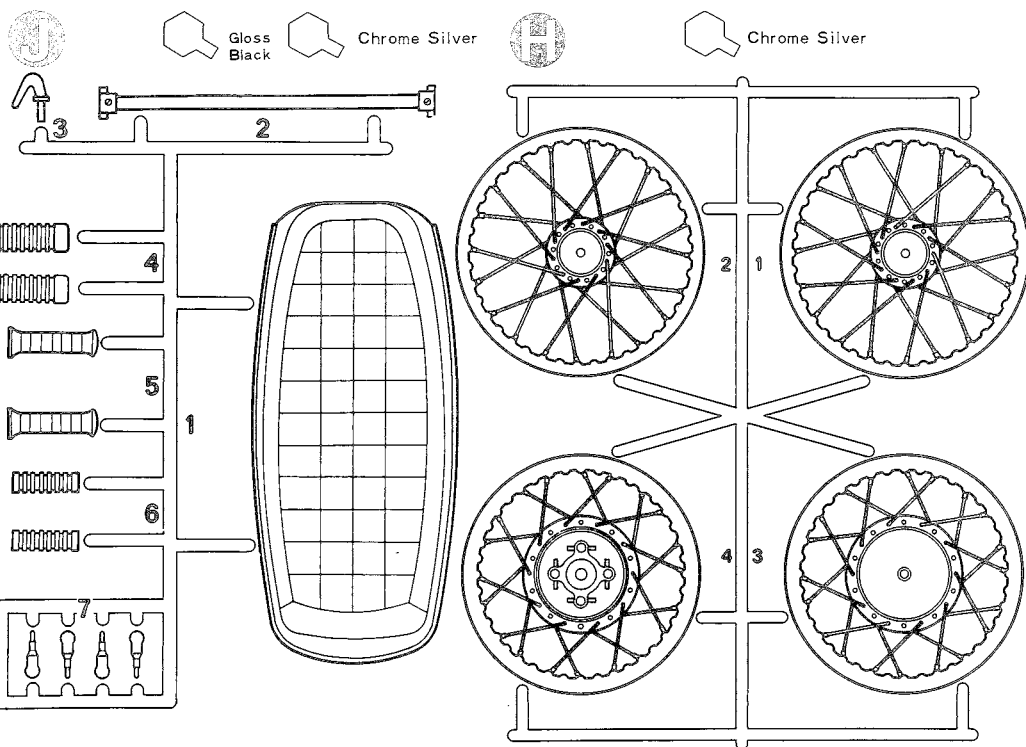

This is not needed.

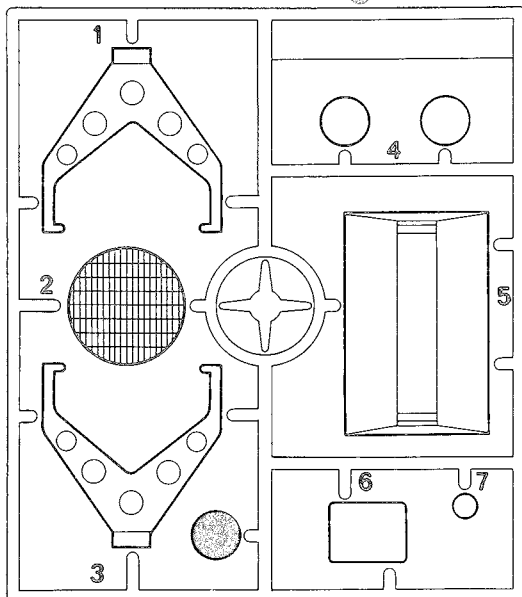

Chain Parts

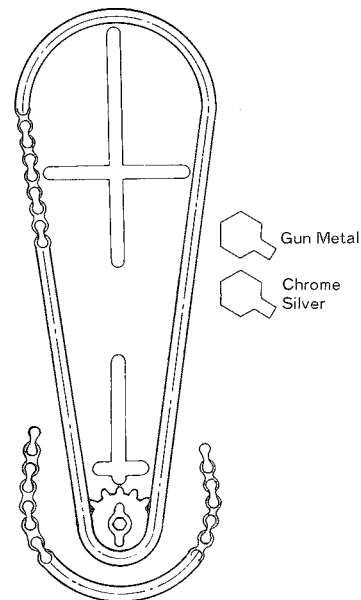

Orange-Coloured Parts

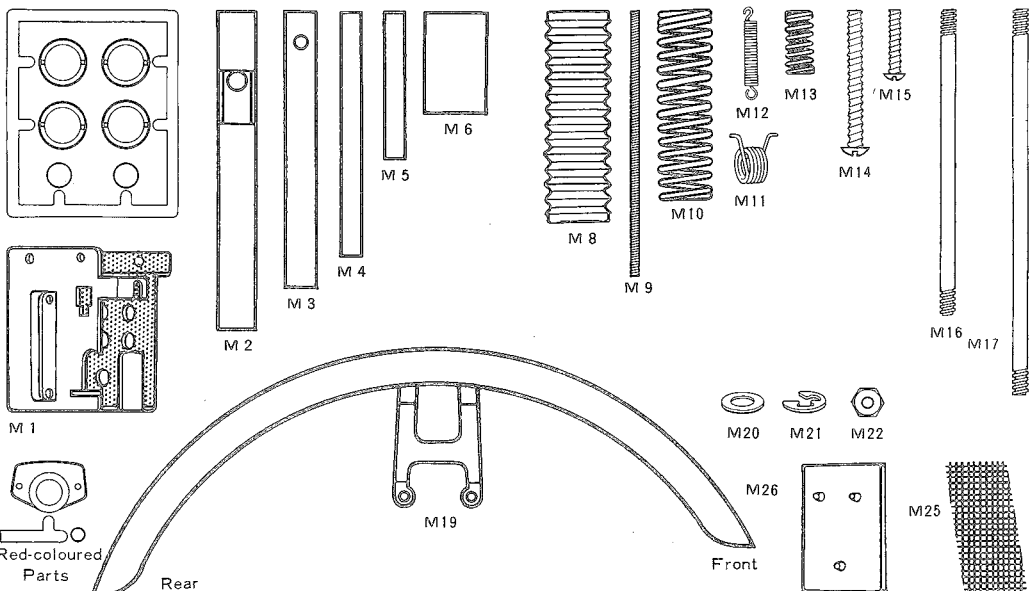

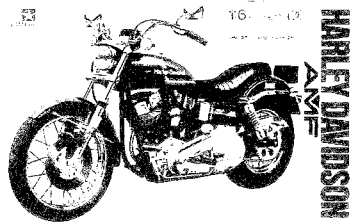

HARLEY-DAVIDSON
AMF

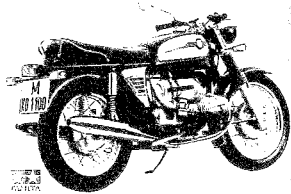

BMW R75

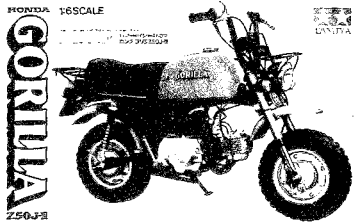

GORILLA
1/6 SCALE
AMF

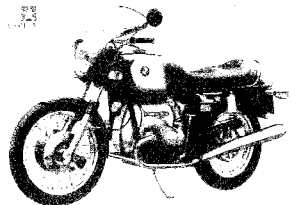

BMW R90S
1/6 SCALE
AMF

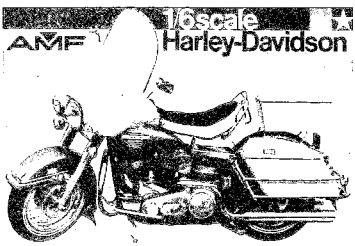

1/6 scale Harley-Davidson
AMF

The history of Tamiya 1/6 scale motorcycle series dawned in 1970 with the Honda CB750 as the first item. 1/6 big scale models feature the beauty of the real motorcycle as it is, as well as depiction of intricate mechanisms. This series offers the joy of building and also authentic portrayal of the motorcycle.

★Some of shown products have been discontinued.

HONDA CB750 POLICE TYPE

(BS-0604)

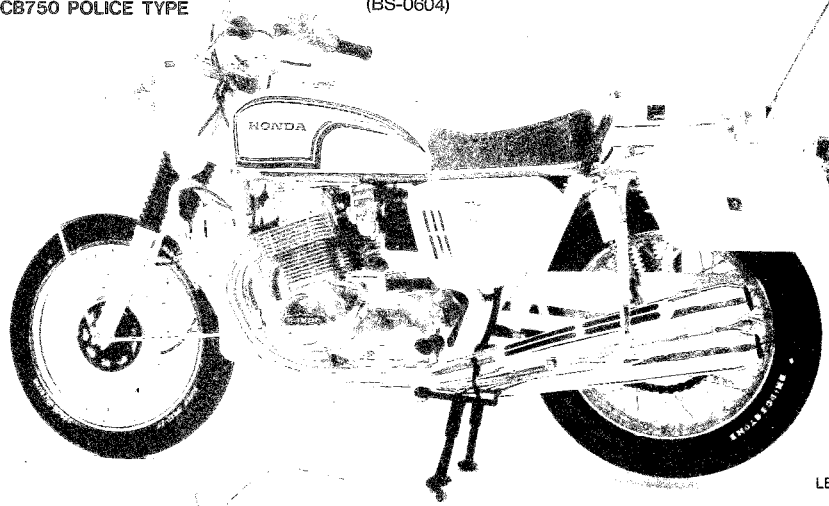

LENGTH 359mm

BMW R90S (BS-0608)

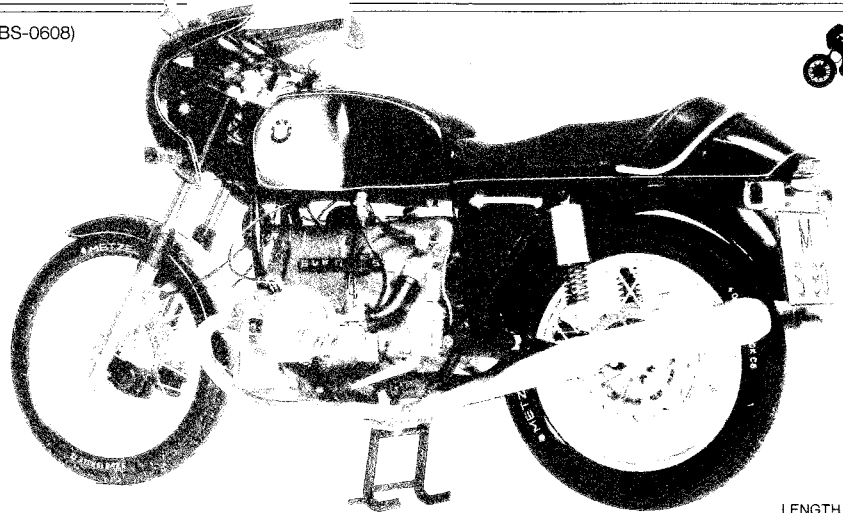

LENGTH 348mm

HARLEY DAVIDSON FXE 1200

(BS-0610)

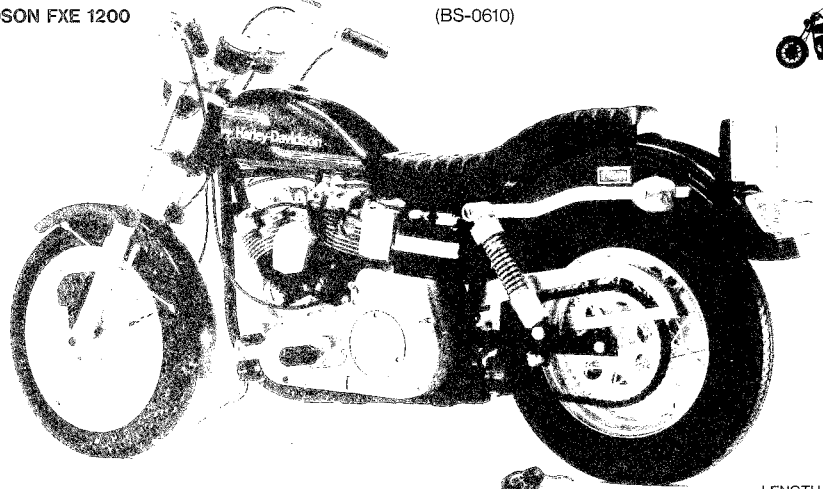

LENGTH 389mm

YAMAHA YZ250 (BS-0611)

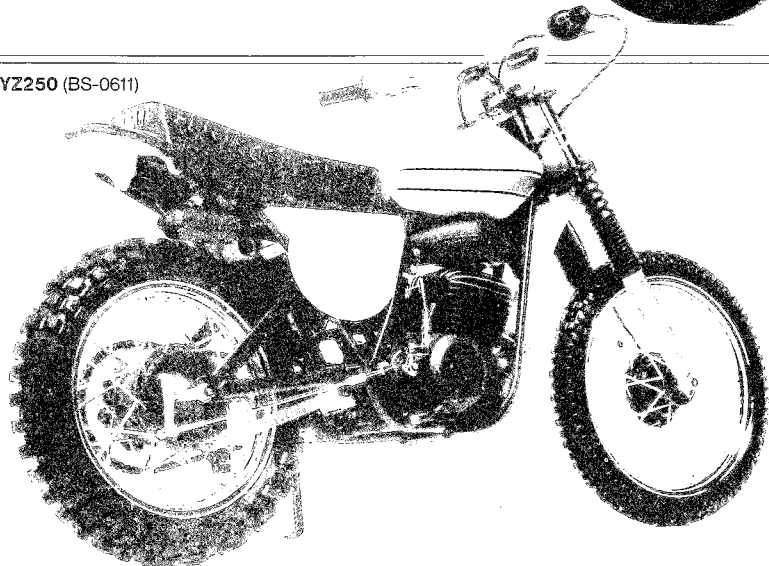

LENGTH 343mm

TAMIYA
TAMIYA, INC.
3-7 ONDWARA, SHIZUOKA-CITY, JAPAN