

Harley-Davidson®

FLH Classic

1/6th SCALE



BIG SCALE 1/5



TAMIYA
TAMIYA PLASTIC MODEL CO.
3-7 ONDAMARA, SHIZUOKA-CITY, JAPAN

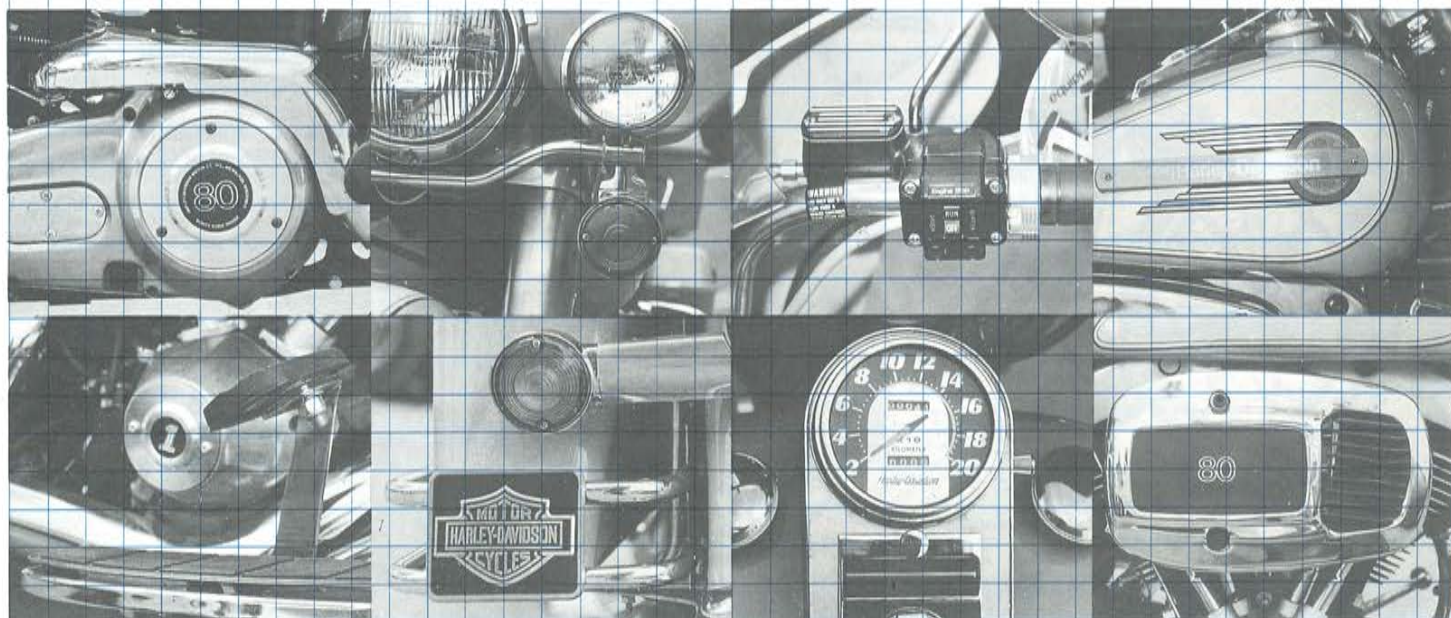
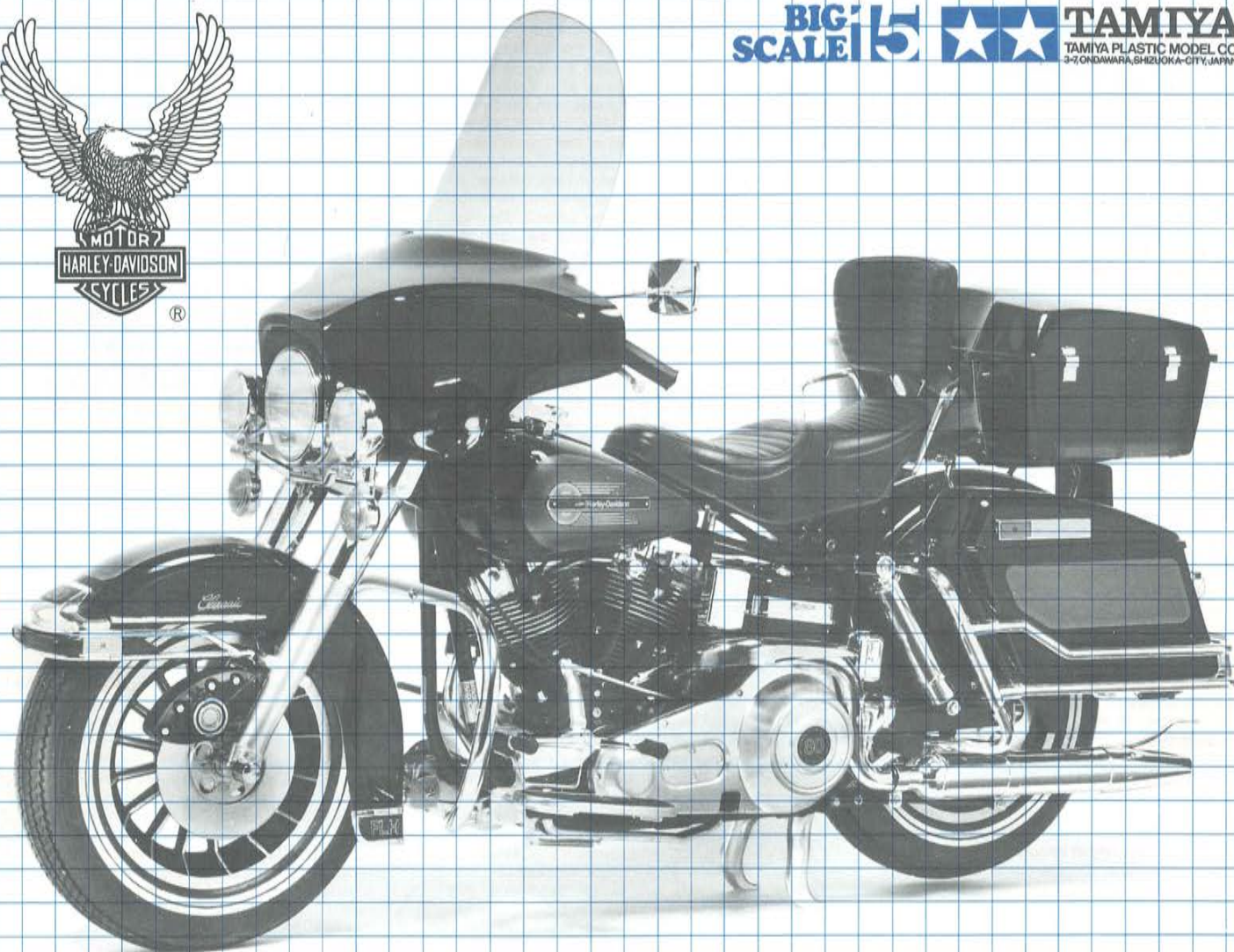

Harley-Davidson® FLH Classic

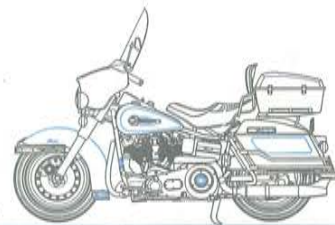

By courtesy of the
Harley-Davidson Motor Company, Inc.

In 1901 two young men, William S. Harley and Arthur Davidson, became interested in making motorcycles and were later joined by Davidson's two brothers. They had only minimal technical data to follow, insufficient tools and lack of money. In spite of this, with the help of O. Evinrude, who was later successful in the development of outboard motors, these four men were able to achieve their dream of creating an entirely new kind of machine. Their first motorcycle had a 406cc engine offering about 3 hp and employing a belt drive system. Most of the main parts were hand made. In 1903 with the financial help of the Davidson brothers' father, a small workshop was built in their backyard. Three motorcycles are believed to have been built that year and in 1904, with an enlarged workshop, eight machines were manufactured. In 1906 a new big factory was built in Milwaukee, the site of the present company, and in 1907 the Harley Davidson Motor Company was formed. That year 150 vehicles were produced. The company tried actively to develop new techniques and released the first V twin engine model in 1909, a clutch mechanism in 1912 and a drum brake and two-speed transmission in 1914. In 1915 they succeeded in developing a revolutionary three-speed transmission. The company began to enjoy world-wide fame when they started releasing models with a V twin engine. A 1200cc V twin engine vehicle was released in 1922 and an economical single engine type in 1926. In the 1930's demand for high-performance machines increased and in 1936 Harley Davidson added a 1300cc V twin engine model to their range. Soon after that, the 938cc OHV V twin engine model 61 was released. This had such advancements as semi-spherical combustion chambers and dry-sump system. The two world wars contributed in no small measure to the development of the company, and production of their military WLA 45 with a V twin engine of 738cc reached 90,000. After WWII small 125cc 2-stroke motorcycles and scooters were manufactured. Harley Davidson became the United States only motorcycle manufacturing company in 1953 when their rivals, Indian, ceased trading, and they further consolidated their position by absorbing Aermacchi of Italy in the 1960's. The FLH 80 Classic, the best model ever produced by Harley Davidson, made its debut in 1979. It is based on the FLH 120 Electra Glide. The "80" of the FLH 80 represents the engine capacity of 80 cubic inches (1,340cc). The Classic and Electra Glide models trace back to the OHV V twin engine model 74 (1200 cc) introduced in 1941. Improvements were

made to the model over the years: in 1948, an aluminium cylinder head and hydraulic tappets were used, in 1949 a telescopic front fork was adopted and the model was given the nickname "Hydra Glide"; in 1959 hydraulic rear dampers were introduced and the nickname changed to "Duo Glide." An electric starter was utilised in 1965 and the engine output increased to 65 hp. This model was given the name "Electra Glide." The engine output was further increased to 66 hp in 1968 and hydraulic disc brakes were fitted to both wheels in 1972. The Electra Glide attracted many fans and was at the time considered the best Harley Davidson machine ever produced. In 1978, celebrating the 75th anniversary of the establishment of the Harley Davidson Motor Company, a limited number of motorcycles with a V twin engine of 1340cc based on the Electra Glide, were produced. In 1979, the 80 series, equipped with the same 1340cc engine, was put into mass production, and the FLH 80 inherited the position of king of motorcycles from the Electra Glide. The FLH 80 does not have anything remarkably new in either composition or mechanism, but is an extremely stable and reliable vehicle. The Classic offers a maximum output of 71 hp with a top speed of about 170 km/h. It is not a sports machine, but is a two-wheeled cruising vehicle for long-distance touring and is vastly suited to the enormous distances covered by an established road network in the United States. The characteristic is typified by its large windshield, comfortable saddle with its unique riding position, large saddle bags and large tour pak. The tough 1340cc engine and the big body, 2m 40cm in overall length and more than 340kg in weight, make for easy, effortless and comfortable driving, and long distance touring becomes more enjoyable. Available usually in two-tones of cream and brown, the FLH 80 Classic can also be found in black and dark silver metallic colouring.

* * *

1901 interessierten sich zwei junge Männer, William S. Harley und Arthur Davidson, Motorräder herzustellen. Später kamen dann noch die zwei Brüder Davidsons dazu. Sie hatten nur wenigen Daten zu folgen, unzureichendes Werkzeug und vor allem wenig Geld. Trotzdem wurden diese vier Männer erfolgreich und konnten ihren Traum verwirklichen durch die Hilfe von O. Evinrude, dem Erfinder der Aussenbord-Motoren. Ihre erste Maschine hatte einen 406 cc Motor mit etwa 3 PS, der Antrieb erfolgte mit einem Treibriemen. Die meisten Teile waren "handmade." Mit finanzieller Hilfe des Vaters der Brüder Davidson

konnte 1903 eine kleine Werkstatt in ihrem Hinterhof eröffnet werden.

Drei Motorräder wurden in diesem Jahr gebaut, 1904 in einer grösseren Werkstatt bereits acht. Eine grosse Fabrik wurde 1906 in Milwaukee gebaut (Sitz der heutigen Firma) und 1907 konnte die Harley Davidson Motor Company gegründet werden.

150 Motorräder konnten in diesem Jahre bereits gebaut werden.

Die Firma entwickelte neue Techniken und 1909 konnte das erste V2 Modell gebaut werden, ein Kupplungsmechanismus wurde 1912, eine Trommelbremse und eine 2-Gang Übersetzung 1914 erfunden und gebaut. Das Jahr 1915 brachte die revolutionäre Dreigang-Schaltung.

Die Firma wurde weltbekannt mit dem Verkauf der V2 Motorräder. 1922 kam die 1200 cc V2 Maschine, und 1926 ein wirtschaftlicher Einzylinder.

In den 30er Jahren steigerte sich die Nachfrage nach leistungstärkeren Maschinen und 1936 baute H.D. bereits eine 1300 cc V2 Maschine, gefolgt von der 938 cc OHV (obengesteuerte Ventile) V2-61 mit Verbrennungskammer und Trockensumpfschmierung. Auch die beiden Kriege konnte die Entwicklung der Firma nicht bremsen und das Modell WLA 45 V2—738 cc erreichte eine Produktion von ca 90.000 Stück. Nach 1945 wurden kleine 125 cc 2-Takt Motorräder und Motorroller hergestellt.

Als 1953 die Firma Indian den Verkauf einstellen wurde Harley Davidson der einzige Produzent in Amerika, der Motorräder herstellte. Auch die Übernahme der Firma Aermacchi in Italien konnte nur die Position Harley Davidsons festigen. Das beste Modell, das je von H.D. hergestellt wurde, die FLH 80 Classic, kam 1979 auf den Markt, und basiert auf der FLH 120 Electra Glide.

Die Zahl "80" bedeutet 80 cub. inches = 1340 cc. Die Classic und die Super Glide gehen beide auf das OHV 2 Zylinder Modell 74 (1200 cc) welche bereits 1941 hergestellt wurde. Natürlich wurden im Laufe der Jahre Verbesserungen an diesem Modell gemacht; 1948 Aluminium Zylinderkopf und hydraulische Ventilstößel, 1949 Teleskopvorderradgabel und den Spitznamen "Hydra-Glide." 1959 kamen hydraulische Stossdämpfer und der Spitzname wurde in "Fuo-Glide" abgeändert. 1965 wurde der elektrische Starter eingebaut und die Motorleistung auf 65 PS erhöht. Neuer Name nun: Electra-Glide. 1968 erfolgte die Auslieferung mit 66 PS und 1972 erhielten die Bremsen hydraulische Scheibenausführung.

Es war die beste Maschine, die Harley Davidson mit der Electra-Glide bis jetzt hergestellt hat.

1978, 75-jähriges Firmenjubiläum, wurde eine begrenzte Anzahl mit dem V2 1340 cc Motor hergestellt. Die 80er Modelle wurden 1979 auch mit dem gleichen 1340 cc Motor produziert und in Massen hergestellt, und die FLH 80 wurde die Königin der Motorräder.

Am Mechanismus gibt es nichts bemerkenswertes Neues, aber die FLH ist eine äusserst stabile und zuverlässige Maschine. Die Classic bringt eine max. Leistung von 71 PS mit 170 km/Stde. Es ist keine Sportsmaschine, aber ein Motorrad für lange Strecken und für die enormen Entfernungen in den US bestens geeignet.

Auffallend ist das grosse Windschild, der bequeme Sitz, grosse seitliche Criffe und grosse Tourentaschen. Der starke Motor mit 1340 cc, die Grösse mit 2,4 Metern und mehr als 340 Kilo Gewicht, macht es leicht, ohne Anstrengungen lange Touren zu fahren.

Die FLH wird in den Farben creme/braun oder schwarz/silbermetallic geliefert.

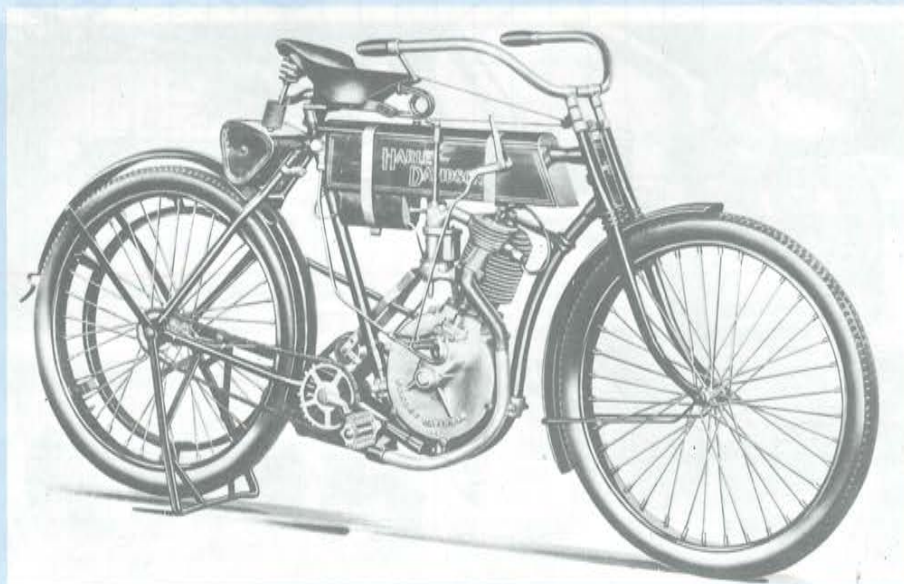

READ BEFORE ASSEMBLY.
ERST LESEN — DANN BAUEN.

- * Study the instructions and photographs before commencing assembly.
- * You will need a sharp knife, a screw-driver, a file and a pair of pliers.
- * Do not break parts away from sprue, but cut off carefully with a pair of pliers.
- * Use cement sparingly. Use only enough to make a good bond.
- * Apply cement to both parts to be joined.
- ☛ This mark shows the colour.

- * Vor Beginn die Bauanleitung studieren und den Nummern nach die Elemente zusammenbauen.
- * Bauteile nicht vom Spritzling abbrechen, vorsichtig abschneiden oder abwicken, Teil vor Kleben zusammenhalten, auf genauen Sitz achten. Nicht zuviel Klebstoff verwenden. Kleine Teile hält man mit Pinzette fest.
- * Abziehbilder vorsichtig von der Unterlage im Wasser abschieben, auf richtigen Sitz achten und gut trocknen lassen.
- ☛ Zeichen für Bemalung

☑ : Parts to be cemented
 ☑ : hier ankleben

PAINTING

«Painting of Frame»
 Paint black parts in black. Frame should be carefully painted one side at a time so as to not leave finger marks.

«Bemalung des Rahmens»
 Alle schwarzen Teile in schwarz bemalen. Zuerst eine Seite so lassen sich Fingerdrücke vermeiden.

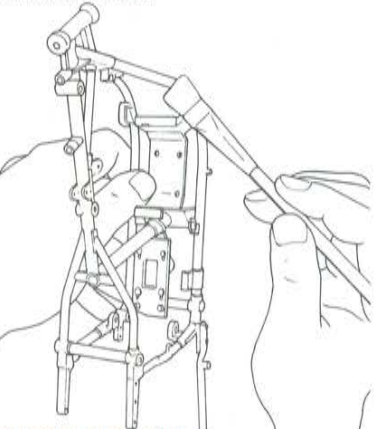

«Timing of Painting»
 Parts to be painted in the same colour should be painted after being assembled. This is the tip for gaining the best result. Parts with adhesives forced out and loosened seams should be filed before painting. Direct your attention even to the smallest screw.

Teile die in gleicher Farbe bemalt werden, sollten nach dem Kleben bemalt werden. Vor dem Bemalen die Klebstoffreste entfernen. Auch auf das kleinste Detail achten.

«Rear Fork»

«Hinteren Gabel»

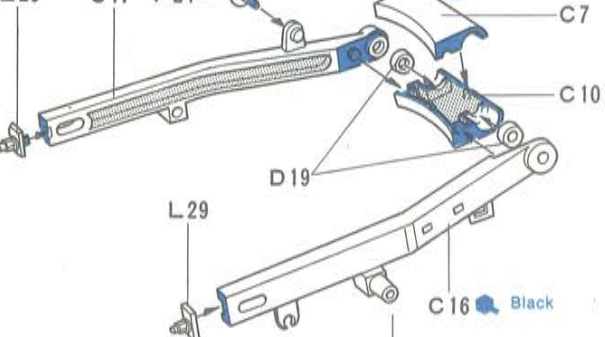

1 Saddle Support
Sattel-Federbein

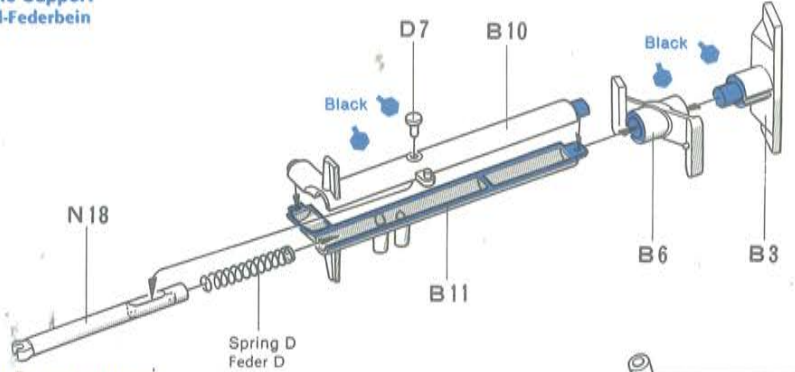

2 Construction of Frame
Rahmenbau

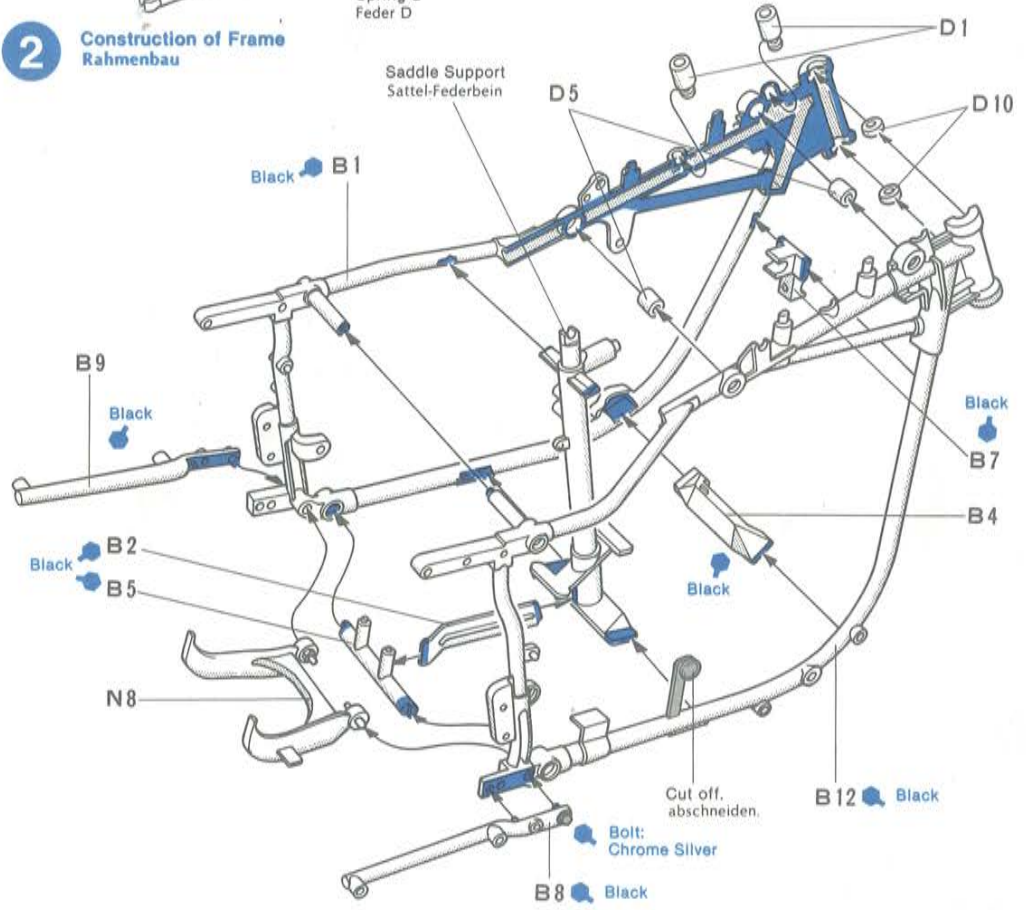

3 Fixing of Chain
Einbau Kette

«Chain»
 «Kettenbau»

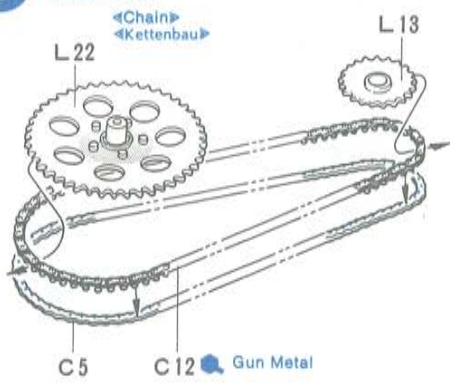

«Cross Section of Chain»
 «Querschnitt Kette»

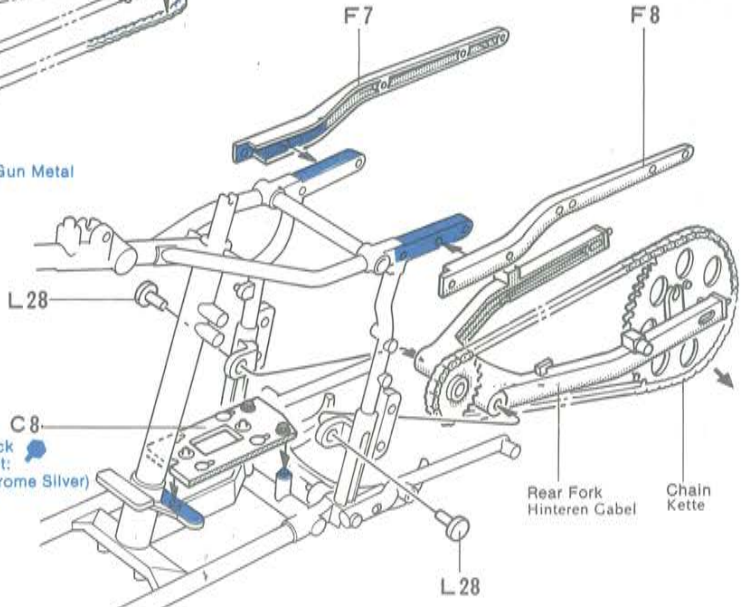
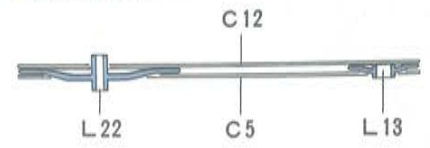

Hold small parts with tweezers to facilitate the work.
Kleine Teile hält man mit Pinzette.

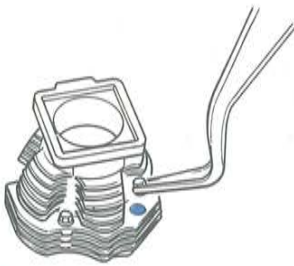

5 «Cylinder 1»
«Zylinder 1»

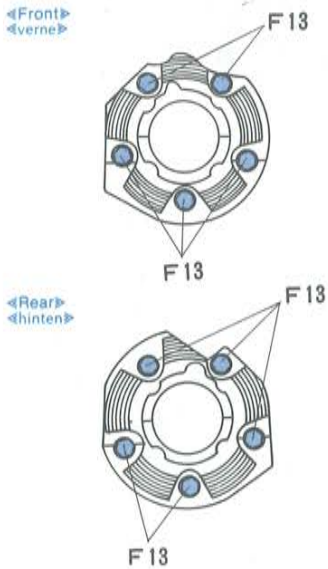

7 «Completion of Engine»
«Motor-Endmontage»



PAINTING

«Painting of Engine»
«Bemalung Motor»
It is recommended to paint the engine with a hard brush.
Harten Pinsel verwenden.

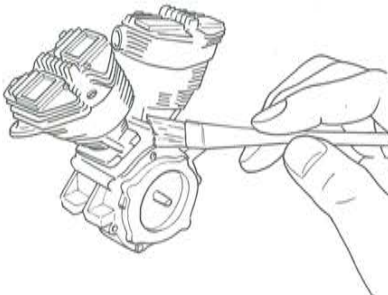

4 Tappet Cover
Ventil-Deckel

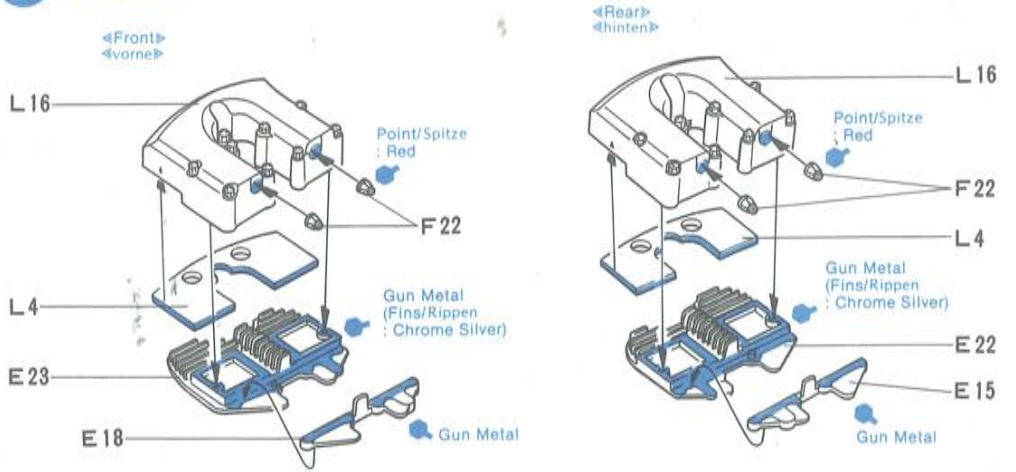

5 Cylinder 1
Zylinder 1

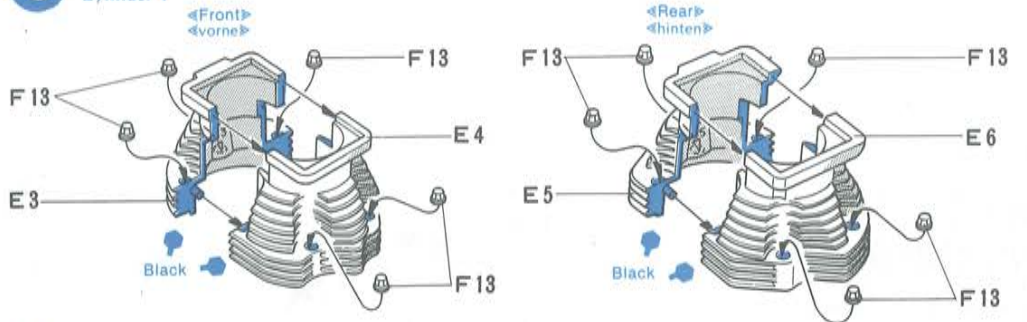

6 Cylinder 2
Zylinder 2

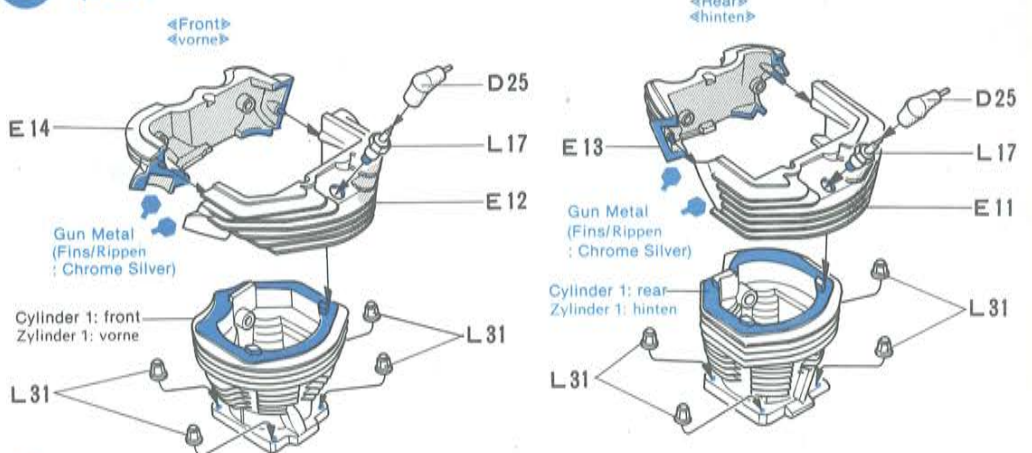

7 Completion of Engine
Motor-Endmontage

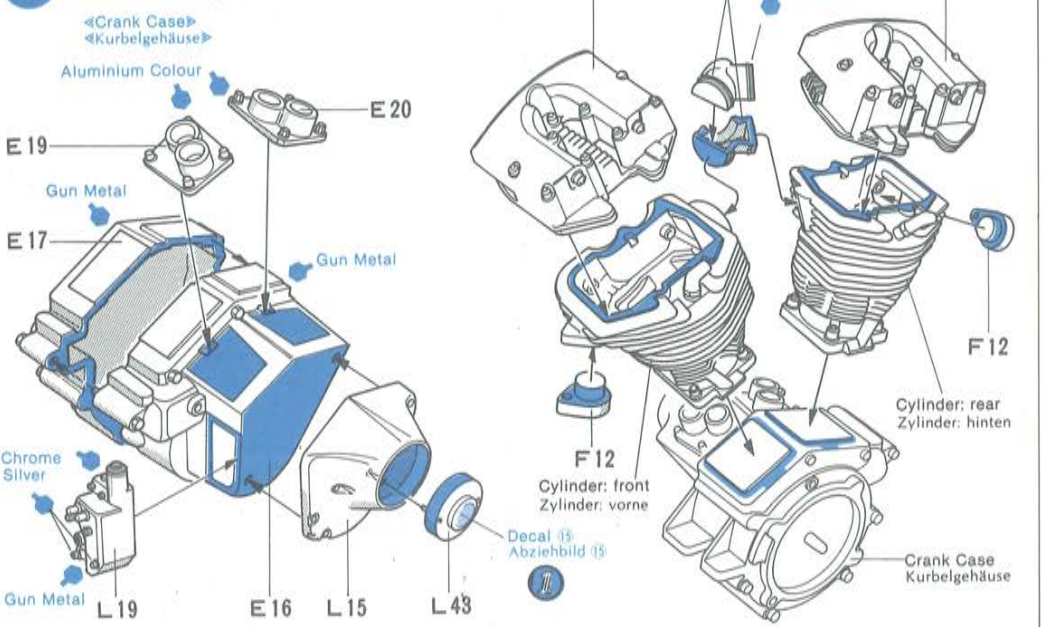

PAINTING

«Painting Bolts»

All the bolts used in the frames and the engine are chrome plated. Paint them with care, since they serve to enhance to overall appearance of your finished model.

«Bemalung der Bolzen»

Alle Bolzen im Rahmen und Motor sind chrome-sorgfältig bemalen. Sie erreichen dadurch ein besseres Aussehen des Modells.

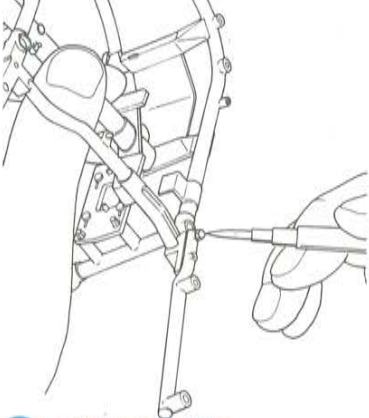

9 «Fixing of Engine» «Einbau Motor»

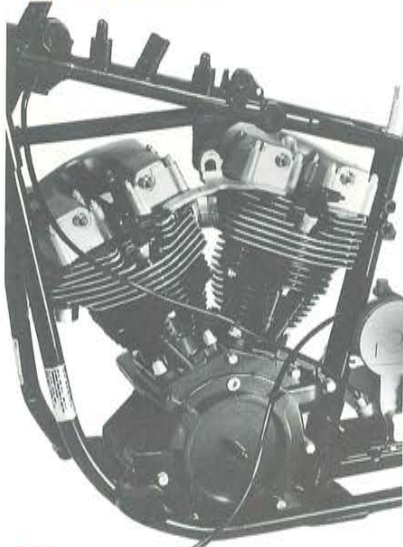

10 «Fixing of Chain Case» «Einbau Ketten-Gehäuse»

«Side Stand»
«Seitenständer»

«Step 1»

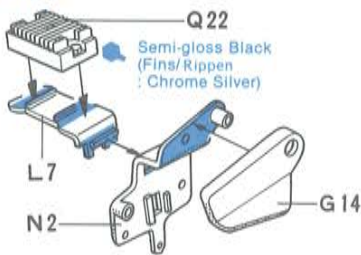

«Step 2»

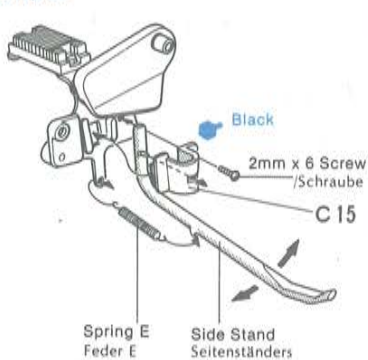

8 Chain Case Ketten-Gehäuse

«Chain Case»
«Ketten-Gehäuse»

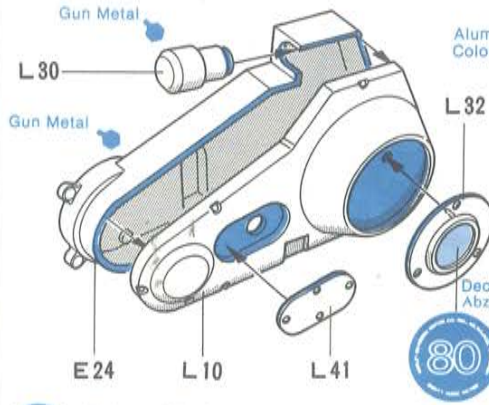

«Gear Case»
«Getriebe-Gehäuse»

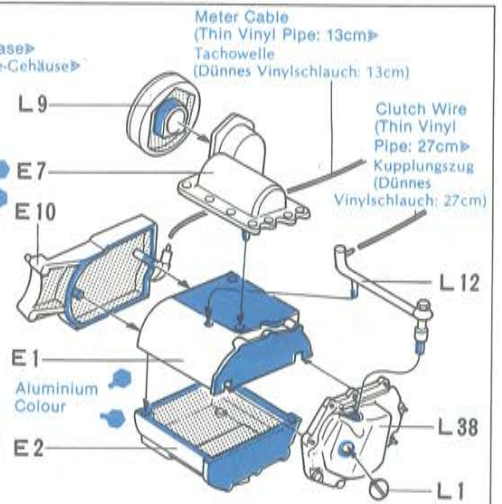

9 Fixing of Engine Einbau Motor

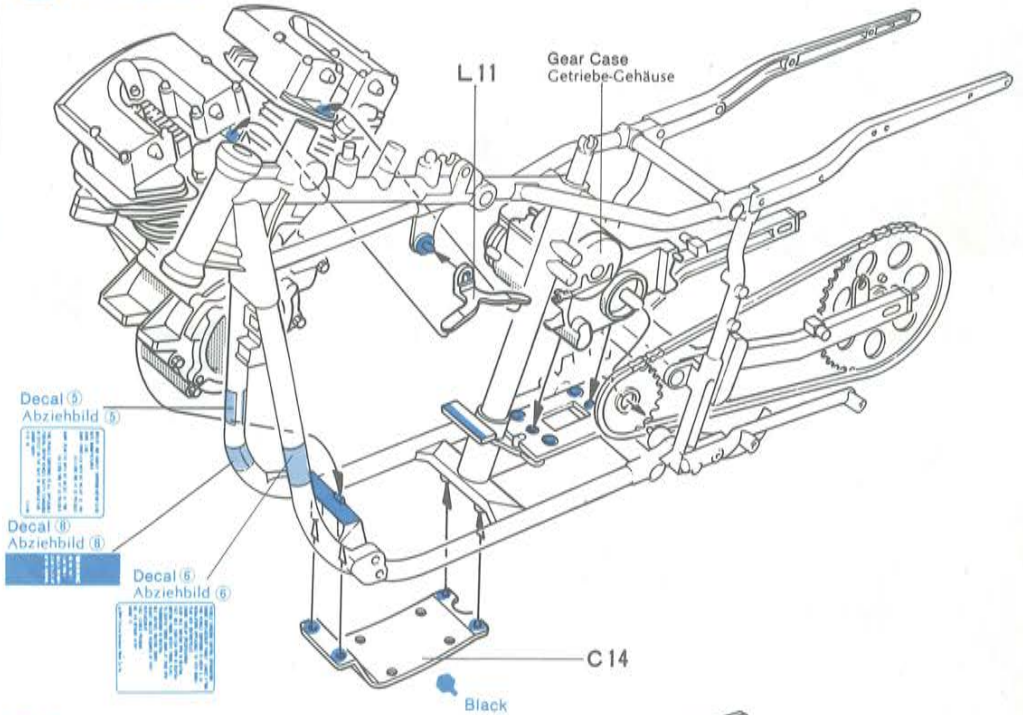

10 Fixing of Chain Case Einbau Ketten-Gehäuse

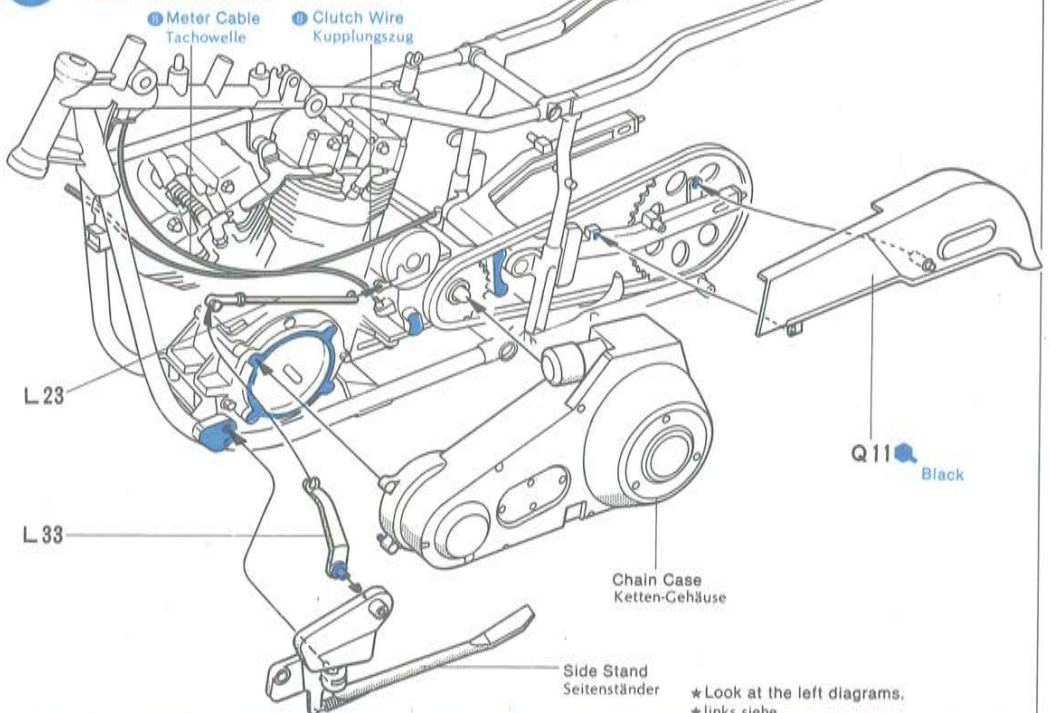

★ Look at the left diagrams.
★ links siehe.



11 «Brake Pedal»
«Fussbremse»



12 «Fixing of Brake Pedal»
«Einbau der Fussbremse»
«Fixing of L24»
«Einbau der L24»



«Fixing of F15s»
«Einbau der F15s»



14 «Rear Fender»
«Hinteren-Schutzblech»



11 Brake Pedal
Fussbremse

«Step 1»

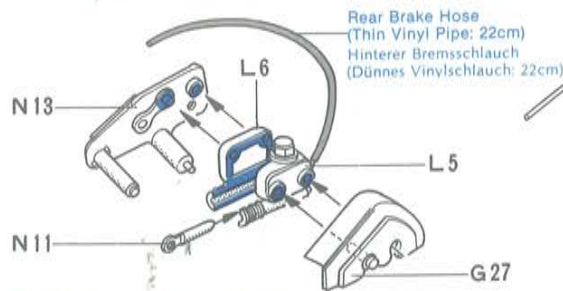

«Step 2»

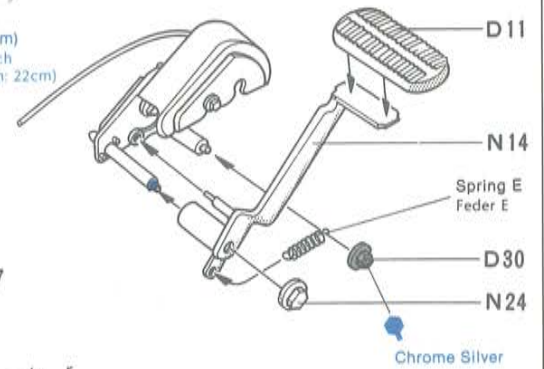

12 Fixing of Brake Pedal
Einbau der Fussbremse

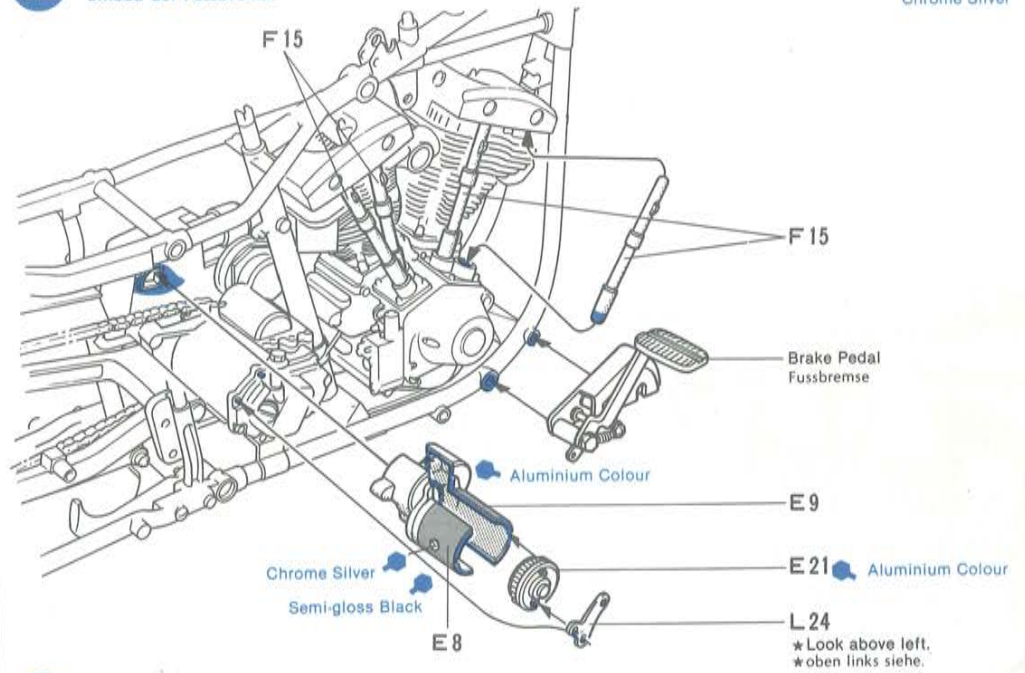

13 Rear Fender Parts
Hinteren-Schutzblech Teile

«Tail Lamp»
«Rückleuchte»

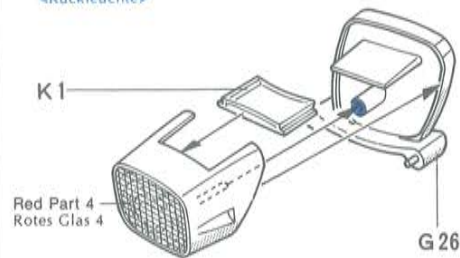

«Rear Bumper»
«Hinterer Stossfänger»

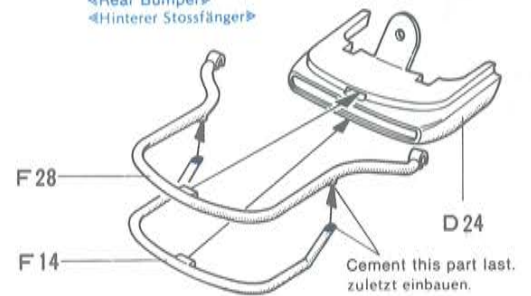

14 Rear Fender
Hinteren-Schutzblech

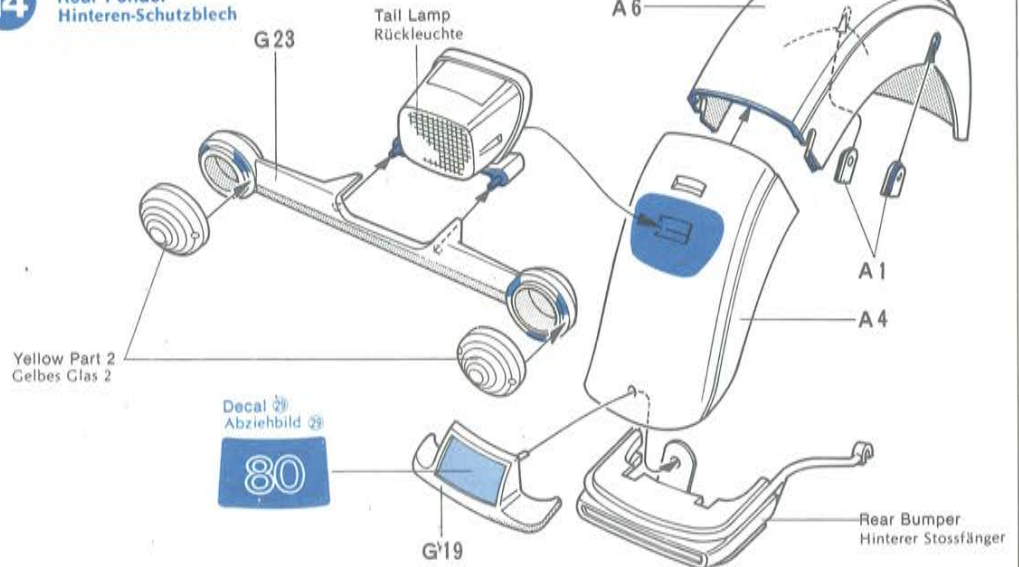

15 <Oil Tank and Battery>
<Öl Tank und Batterie>



15 Oil Tank and Battery
Öl Tank und Batterie

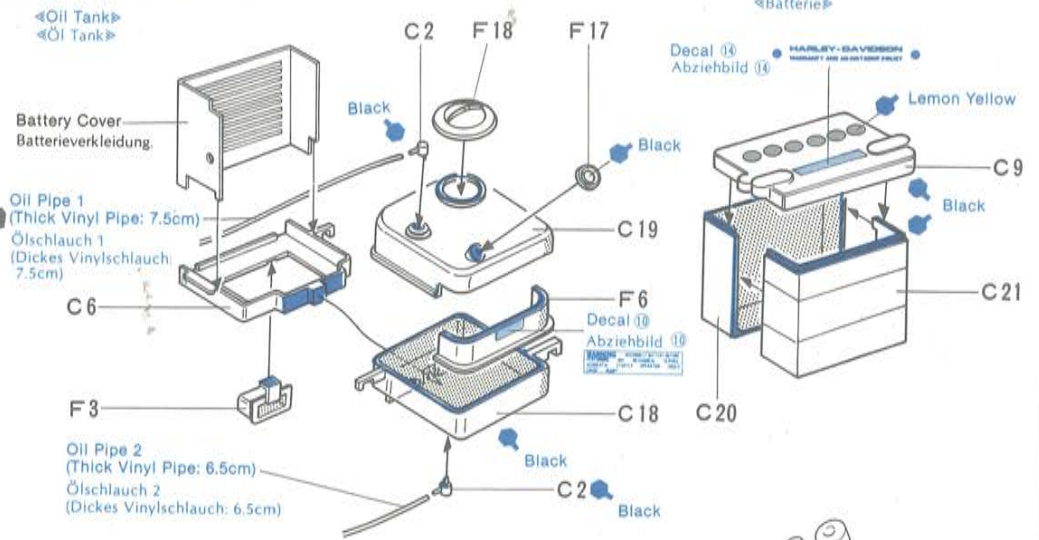

16 <Fixing of Rear Fender>
<Einbau der Hinteren-Schutzblech>



16 Fixing of Rear Fender
Einbau der Hinteren-Schutzblech

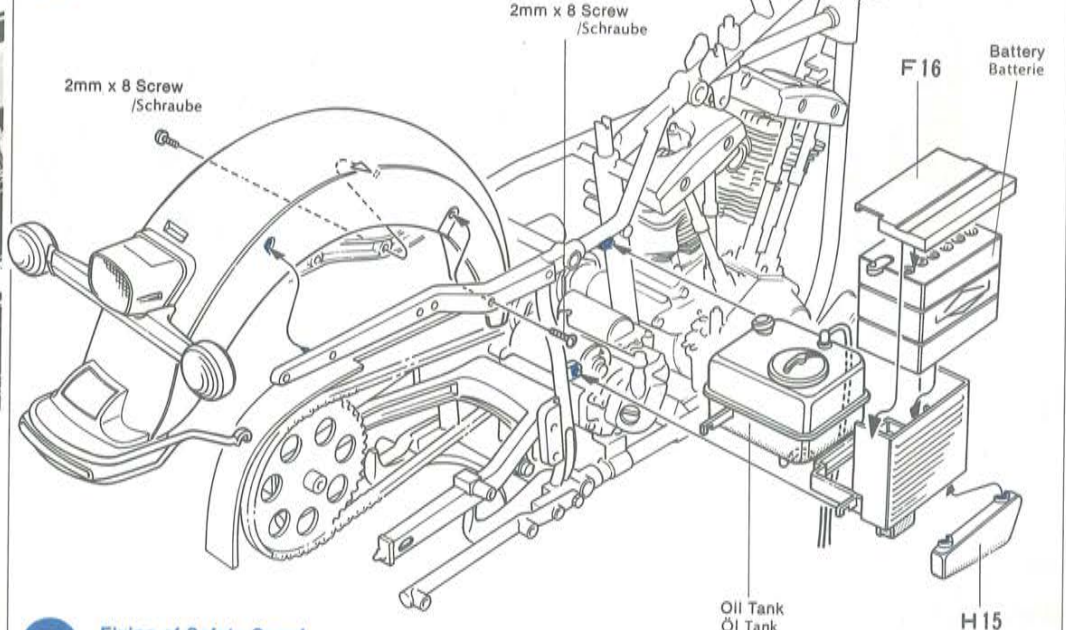

17 Fixing of Safety Guard
Einbau der Schutzbügel

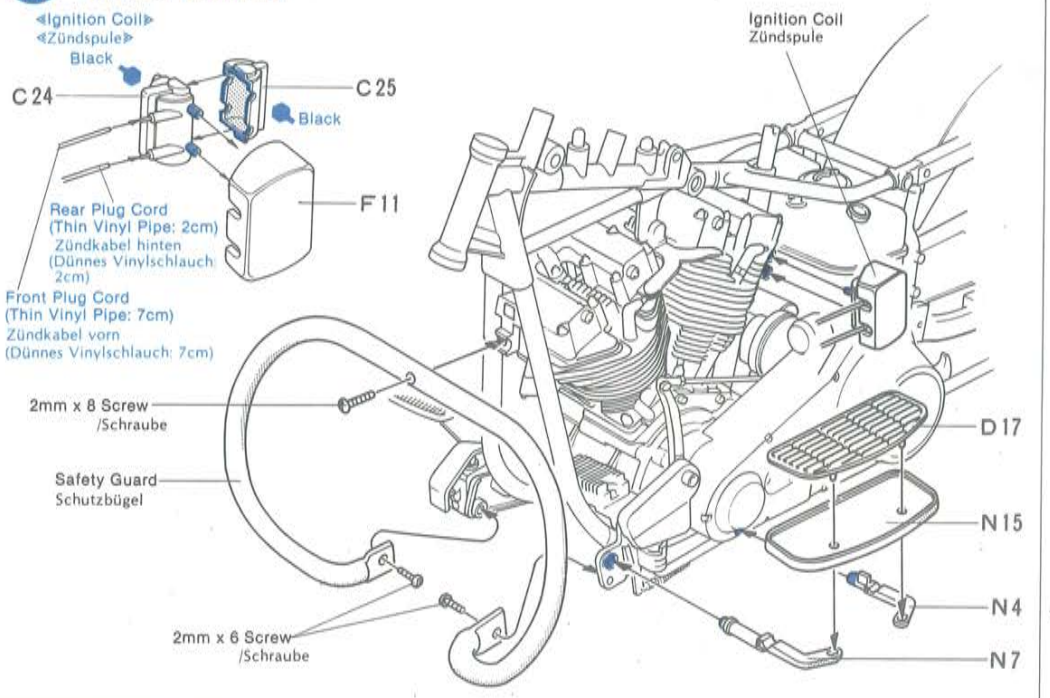

BUILD A COLLECTION OF TAMIYA
PRECISION MOTORCYCLE MODELS
1/6 HARLEY DAVIDSON® POLICE BIKE



1/6 HARLEY DAVIDSON® FXE 1200



18 <<Rear Damper>>
<<Hintere Stossdämpfer>>
<<Cross Section>>
<<Querschnitt>>

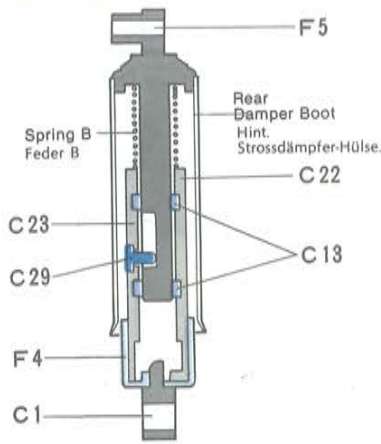

20 <<Rear Wheel>>
<<Hinterrad>>

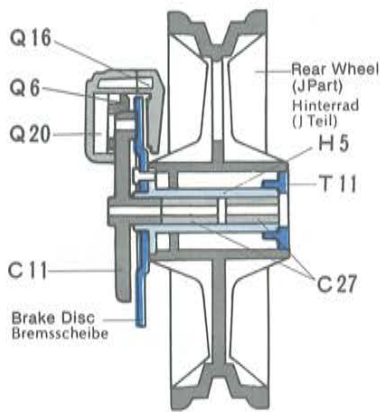

21 <<Fixing of Rear Wheel>>
<<Einbau Hinterrad>>



18 Rear Damper
Hintere Stossdämpfer

<<Step 1>>

★ Make 2 sets.
★ 2 Satz

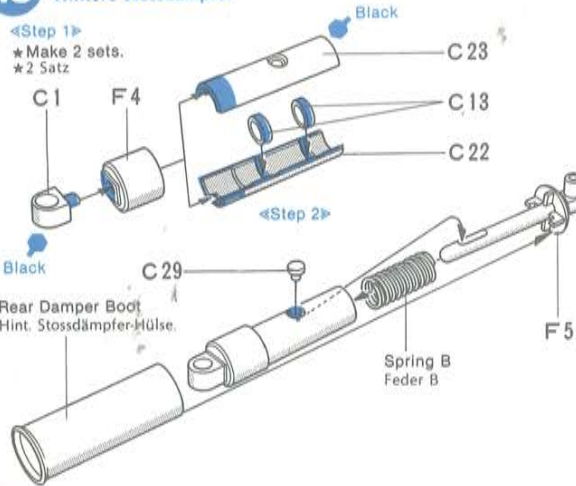

19 Rear Bumper: right
Hintere Fänger: rechts

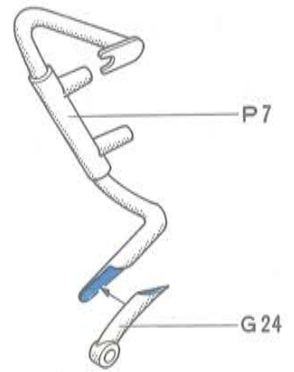

20 Rear Wheel
Hinterrad

<<Step 1>>

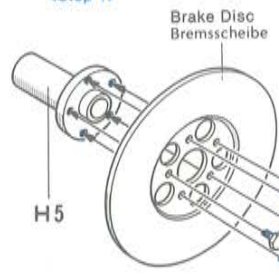

<<Step 3>>

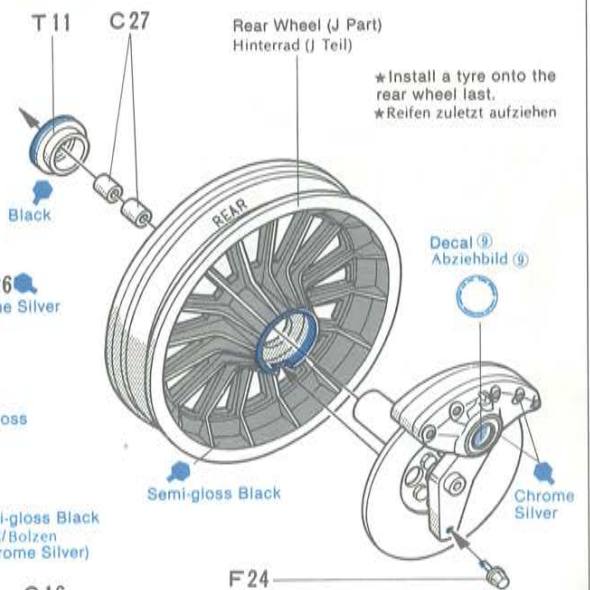

<<Step 2>>

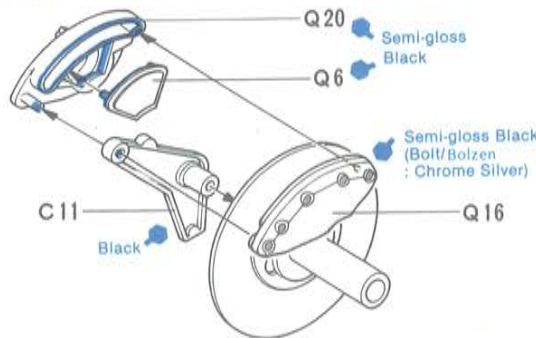

21 Fixing of Rear Wheel
Einbau Hinterrad

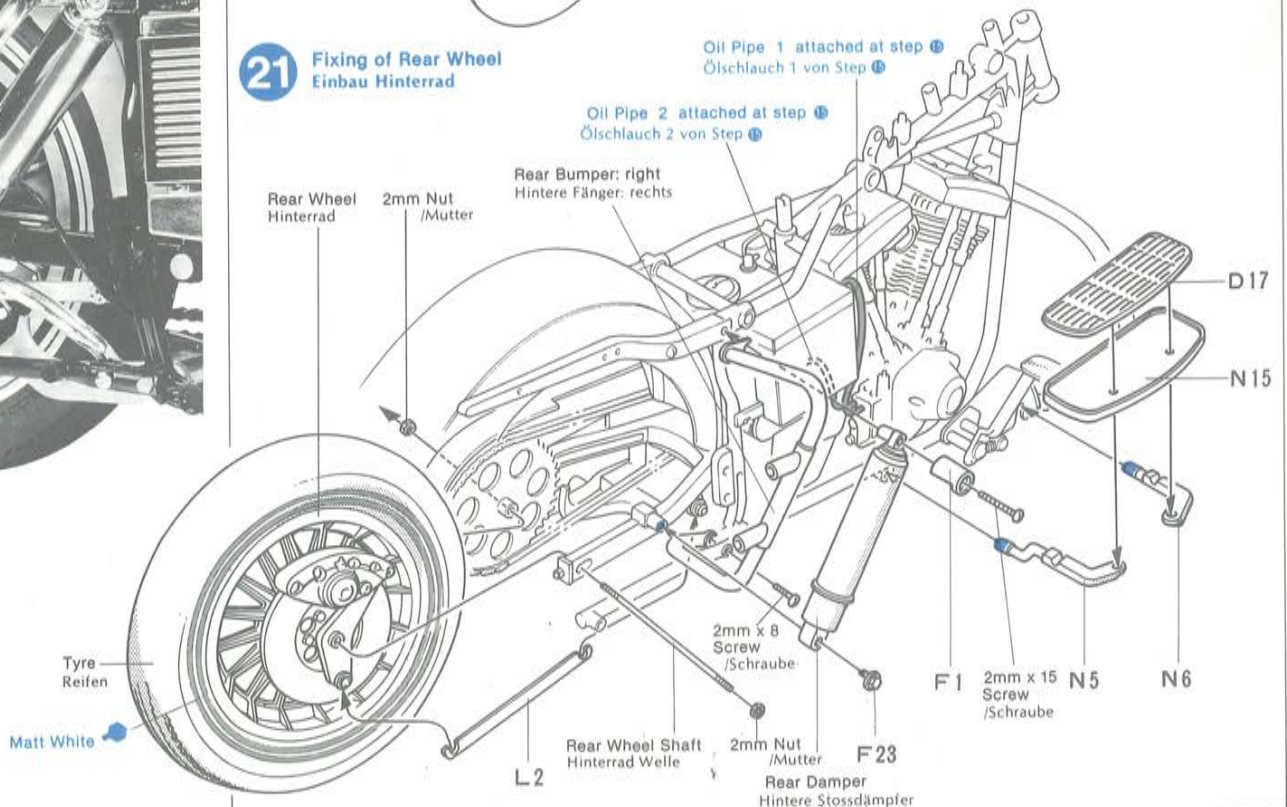

22 «Spare Plug Case»
«Zünkerzen Kasten»



22 Spare Plug Case
Zünkerzen Kasten

«Spare Plug Case»
«Zünkerzen Kasten»

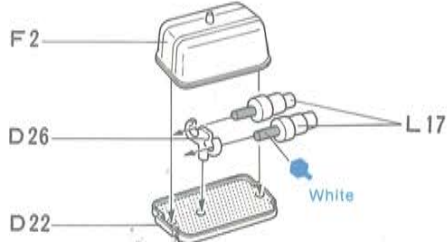

«Rear Bumper; left»
«Hintere Fänger: links»

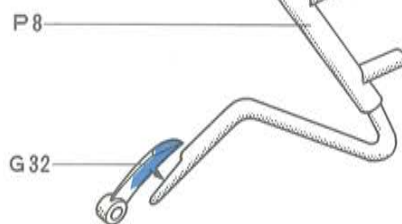

23 «Saddle Frame»
«Sattel-Rahmen»

«Front View»



«Rear View»

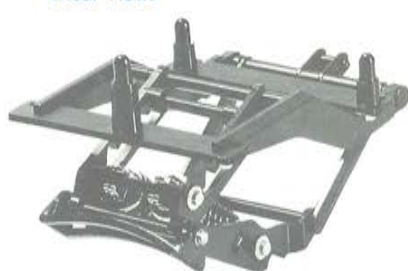

23 Saddle Frame
Sattel-Rahmen

«Saddle Frame A»
«Sattel-Rahmen A»

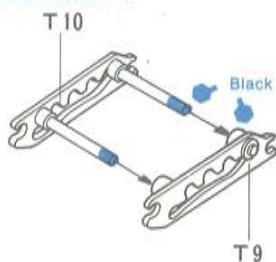

«Saddle Frame B»
«Sattel-Rahmen B»

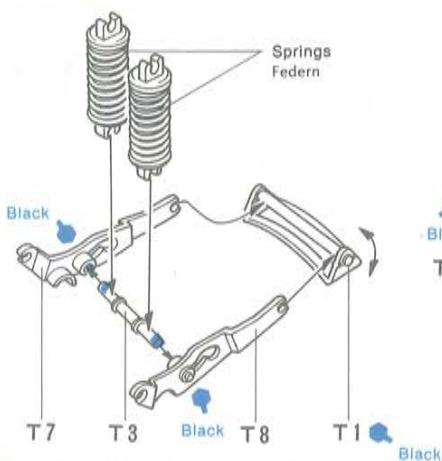

«Spring»
«Feder»
* Make 2 sets.
* 2 Satz

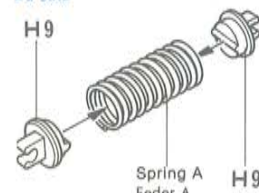

«Completion»
«Endmontage»

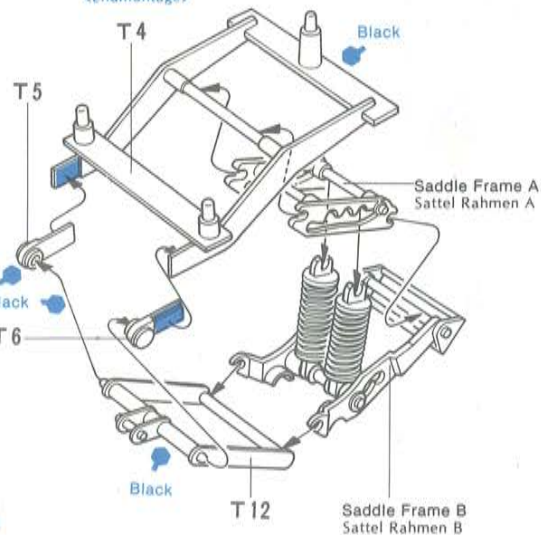

24 «Fixing of Saddle Frame»
«Einbau der Sattel-Rahmen»

24 Fixing of Saddle Frame
Einbau der Sattel-Rahmen

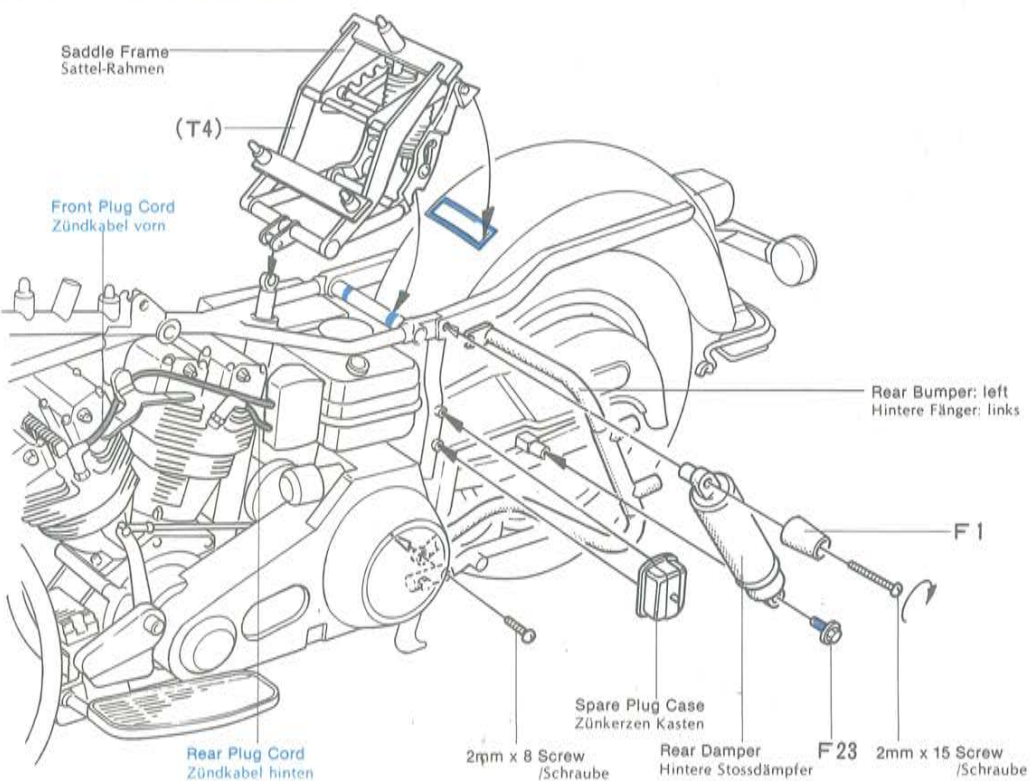

25 «Fixing of Saddle Bag Stay»
«Einbau des Sattellagers»

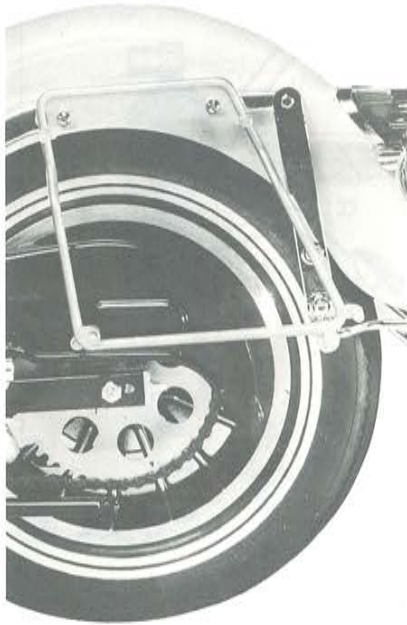

25 Fixing of Saddle Bag Stay
Einbau des Sattellagers

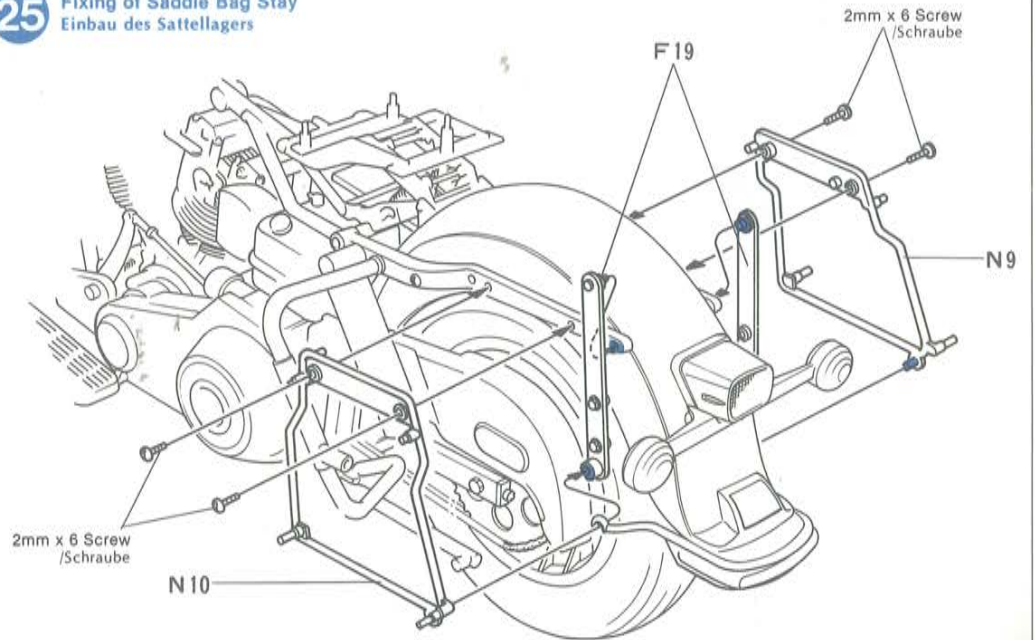

27 «Front Fork 2»
«Vorderrad-Gabel 2»

«Cross Section»
«Querschnitt»

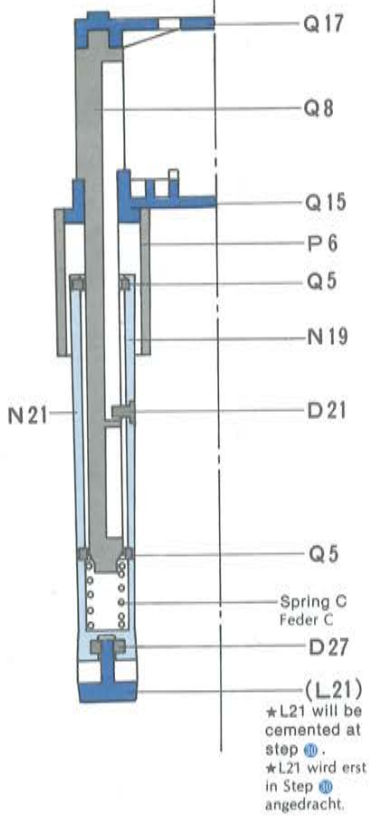

«Q16, Q20»



26 Front Fork 1
Vorderrad-Gabel 1

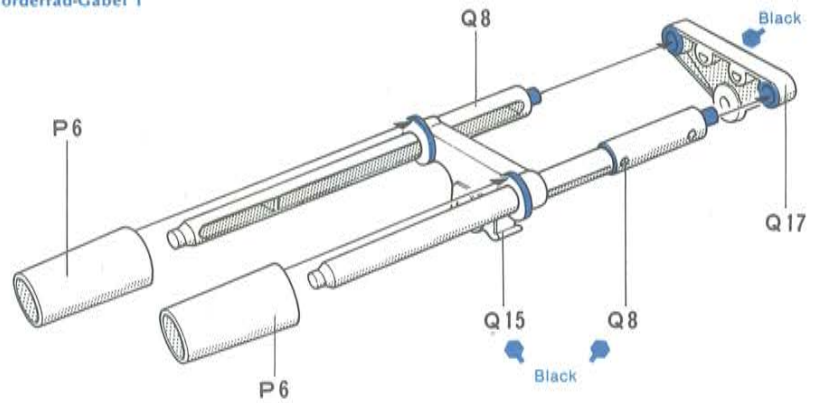

«Outer Tube: right»
«Gabel-Aussenteil: rechts»

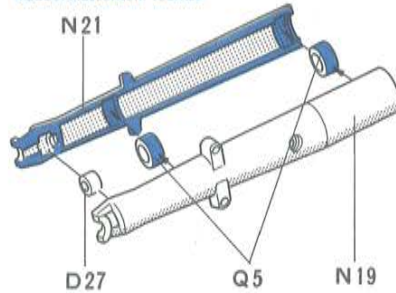

«Outer Tube: left»
«Gabel-Aussenteil: links»

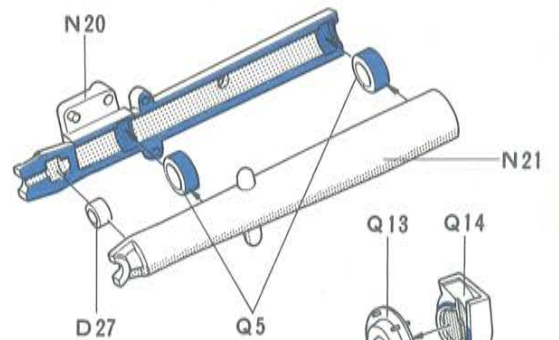

27 Front Fork 2
Vorderrad-Gabel 2

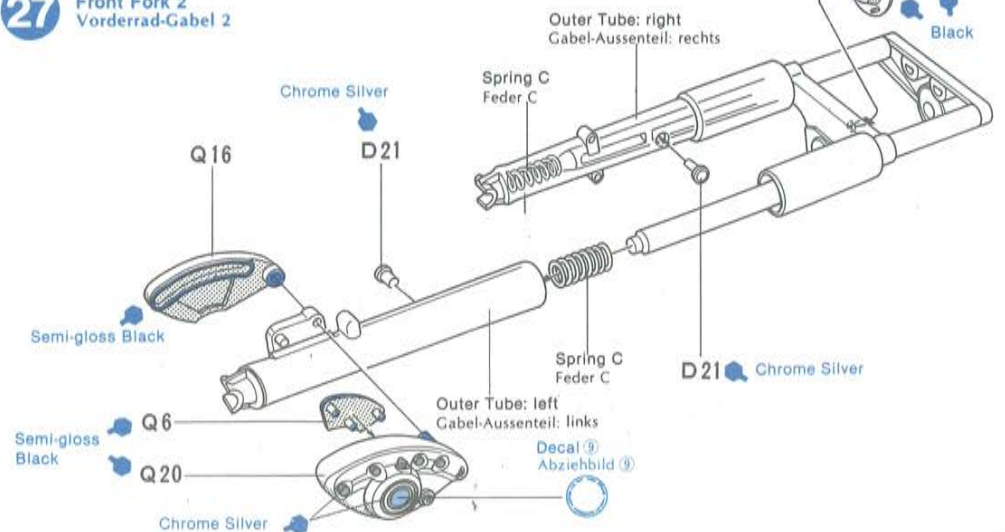

28 «Front Fender»
«Vorderes-Schutzblech»

«Front Bumper»
«Vorderer-Stossfänger»



29 «Front Wheel»
«Vorderrad»

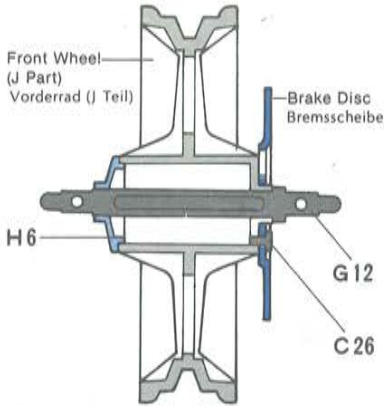

30 «Fixing of Front Wheel»
«Einbau Vorderrad»
«Fixing of Front Fender»
«Einbau des Vorderen-Schutzbleches»

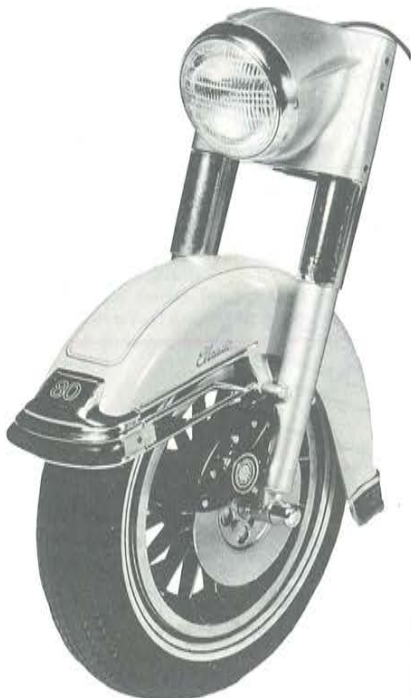
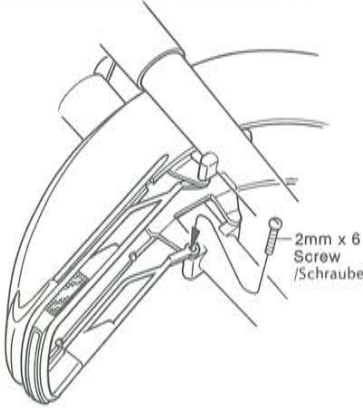

28 Front Fender
Vorderes-Schutzblech

«Front Bumper»
«Vorderer-Stossfänger»

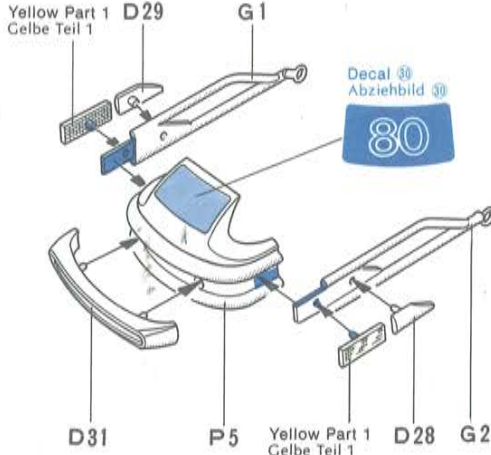

29 Front Wheel
Vorderrad

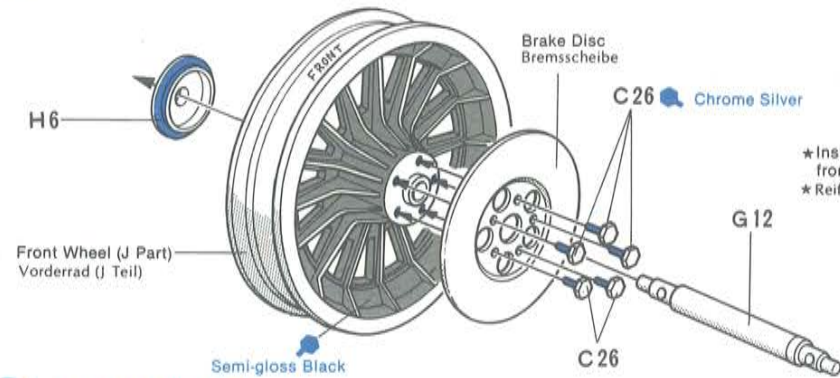

30 Fixing of Front Wheel
Einbau Vorderrad

«Head Lamp»
«Scheinwerfer»

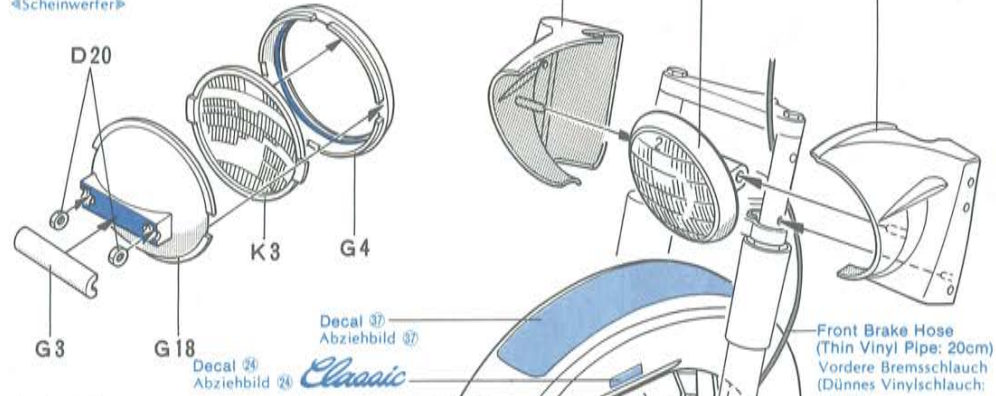

★Apply on the other side also.
★An den gegenteilige Seite ebenfalls befestigen.

Front Bumper
Vorderer-Stossfänger

2mm x 6 Screw
/Schraube

G17

Front Wheel
Vorderrad

Tyre
Reifen

L21

Matt White

G17

L20



31 <Handle Bar> <Lenkstange>

<Q4, Q7>



<Decal ⑧>
<Abziehbild ⑧>



32 <Fixing of Front Fork> <Einbau Vorderrad-Gabel>



PAINTING

<Repair of worn-off plating>

<Chromteile>

Apply silver paint with a very fine pointed brush to make good any damaged chrome work.

Schadhafte Stellen der Chromschicht mit spitzem Pinsel und Silber Farbe ausbessern.



31 Handle Bar Lenkstange

<Clutch Lever>
<Kupplungsgriff>

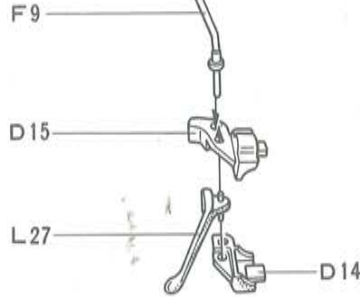

<Q7>

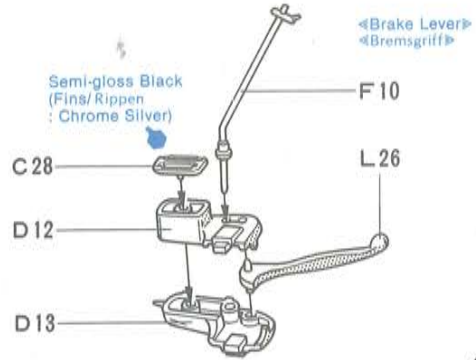
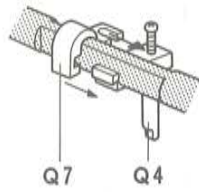

Semi-gloss Black
(Fins/Rippen
: Chrome Silver)

<Brake Lever>
<Bremsgriff>

2mm x 6 Screw
/Schraube Q7

Black

Handle Bar
Lenkstange

Clutch Lever
Kupplungsgriff

Black

Decal ⑧
Abziehbild ⑧

Brake Lever
Bremsgriff

32 Fixing of Front Fork Einbau Vorderrad-Gabel

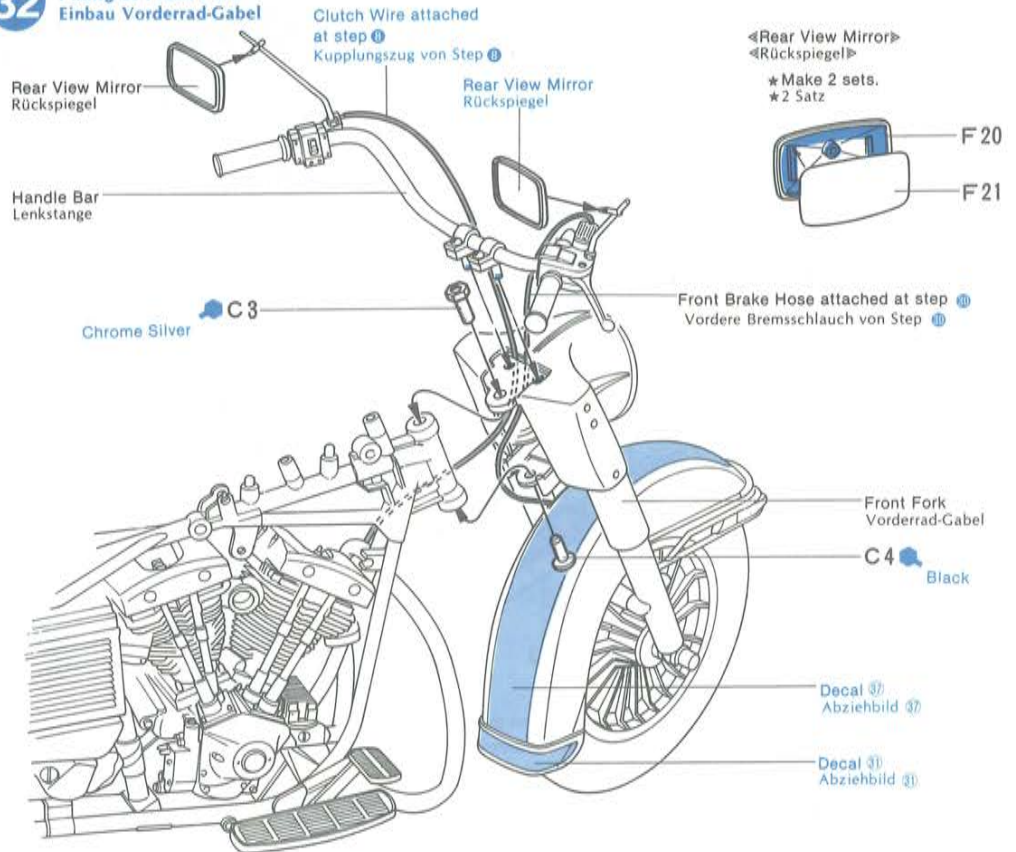

33 Mufflers Auspuffes

<Right>
<rechts>

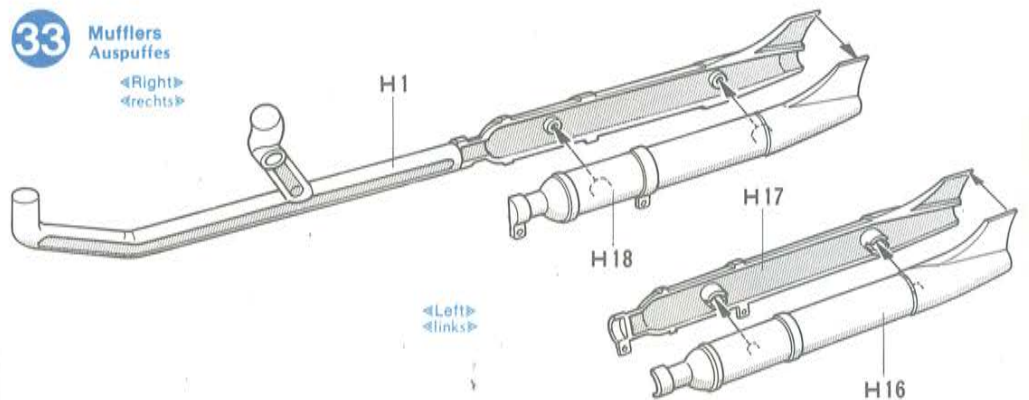

34 «Fixing of Left Muffler»
«Einbau des Linken Auspuff»

Fold and push to catch H8.
Hier biegen und festhalten.

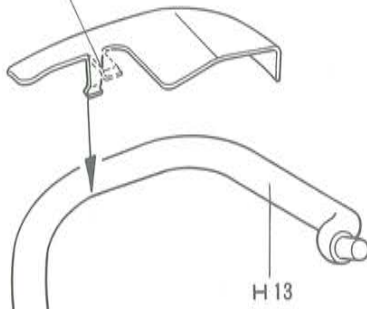

«Fixing of F27»
«Einbau der F27»

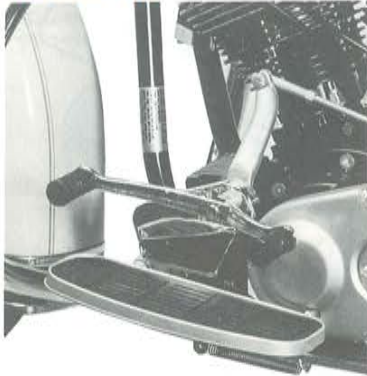

34 Fixing of Left Muffler
Einbau des Linken Auspuff

«Rear Carrier»
«Gespäckhalter»

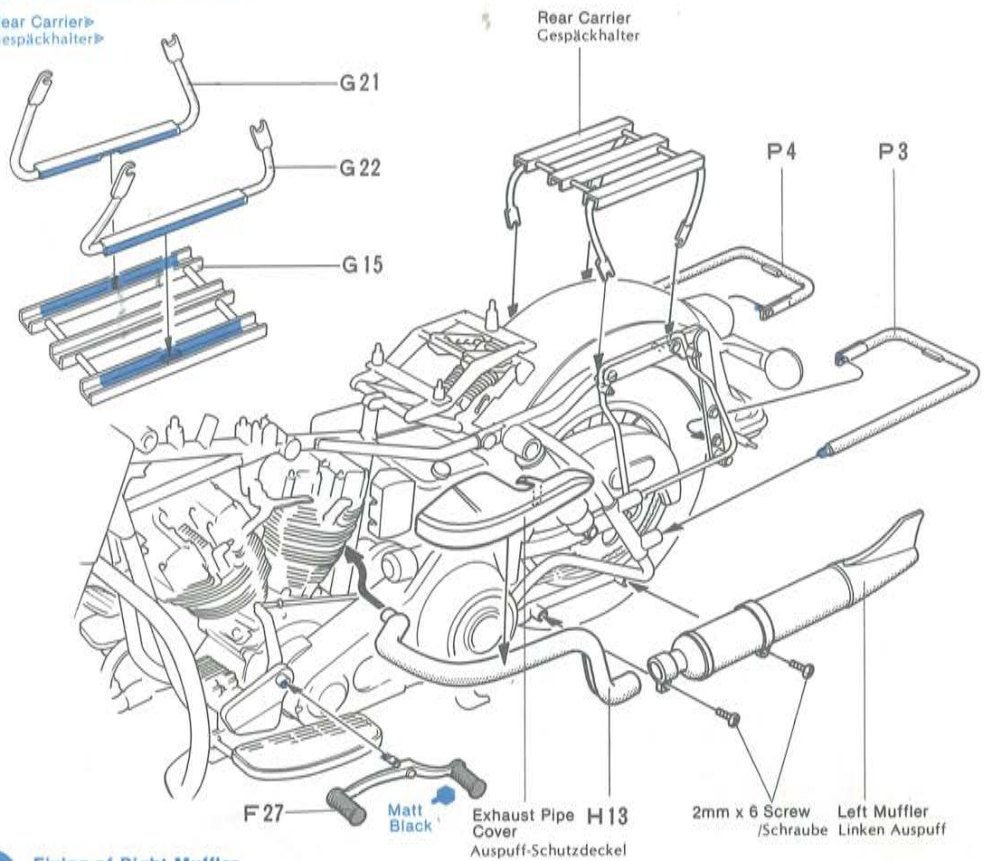

35 Fixing of Right Muffler
Einbau des Rechten Auspuff

«Air Cleaner»
«Luft Filter»

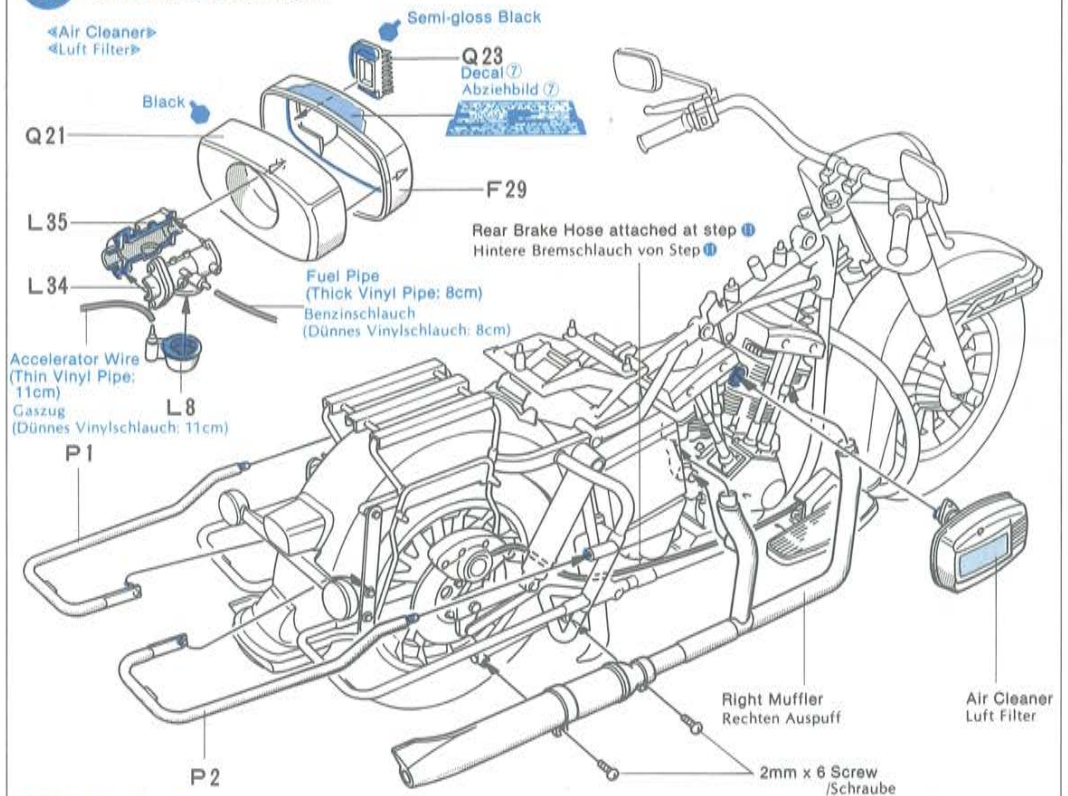

36 «Number Plate»
«Nummernschild»

U.S. Number Plate
US Nummernschild

Decal 22 Abziehbild 22 Decal 23 Abziehbild 23



Japanese Number Plate
Japan, Nummernschild

Decal 34 Abziehbild 34 or 33 34 Chrome Silver



PAINTING

«Painting of Number Plate»
«Nummernschild»

To obtain better result, hold Number Plate on a rest and paint it carefully.
Schild auflegen und dann sorgfältig bemalen.

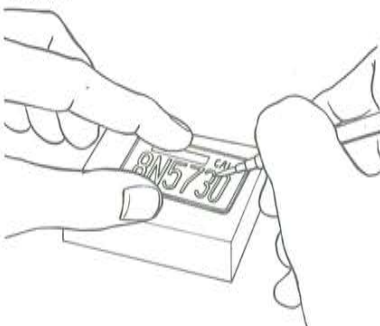

36 Number Plate
Nummernschild

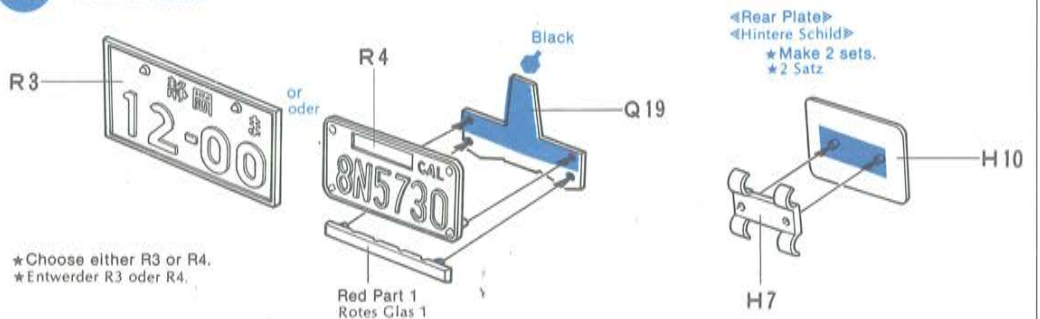

* Choose either R3 or R4.
* Entweder R3 oder R4.

PAINTING

«Finish of Painting»

After the paint has dried well, polish with great care the whole body with a small amount of rubbing compound or wax. This will give your model a really high gloss.

«Bemalung»

Nach gutem Trocknen der Farbe kann man alle Flächen mit etwas Wachs polieren, das gibt dem Modell erst den richtigen Glanz.



38 «Fuel Tank»

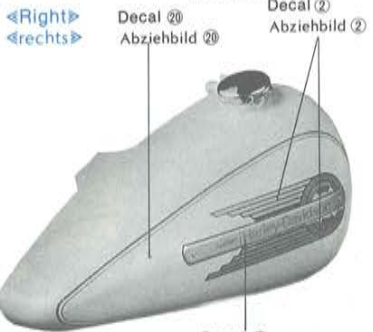
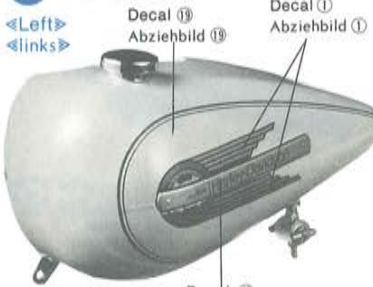

39 «Fixing of Saddle Bags»



37 Saddle Bags Satteltaschen

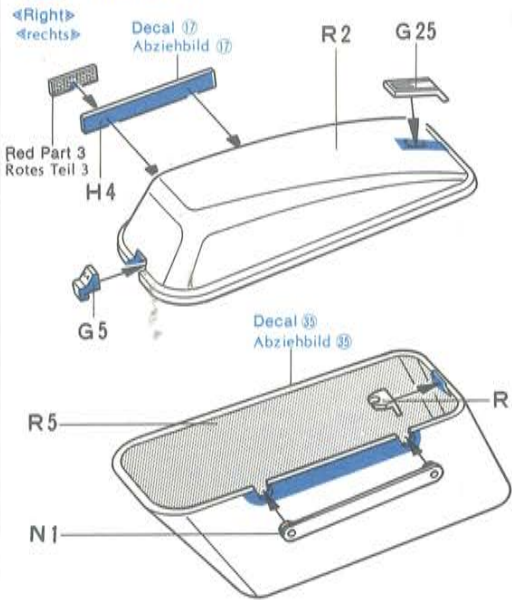

«Left»
«links»

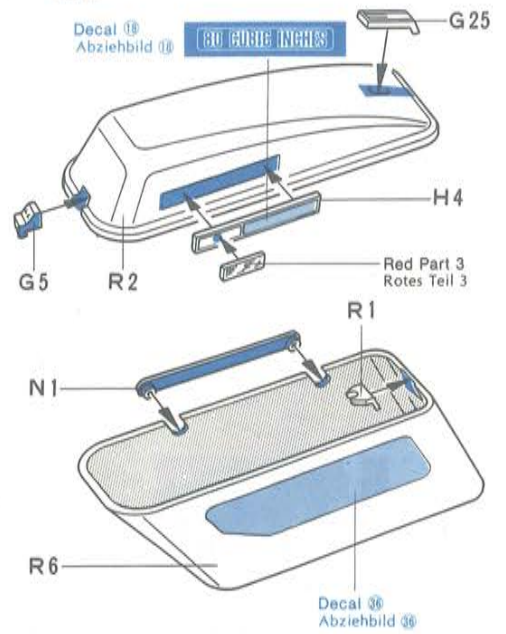

38 Fuel Tank Tanks

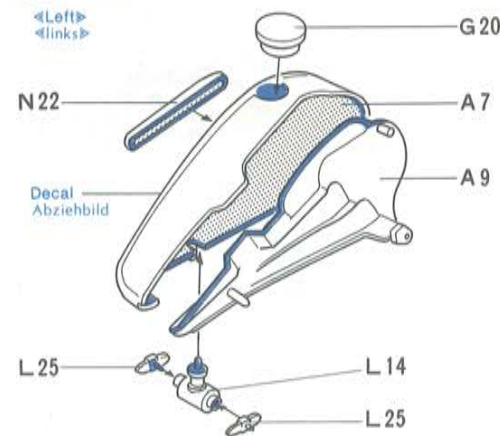

«Right»
«rechts»

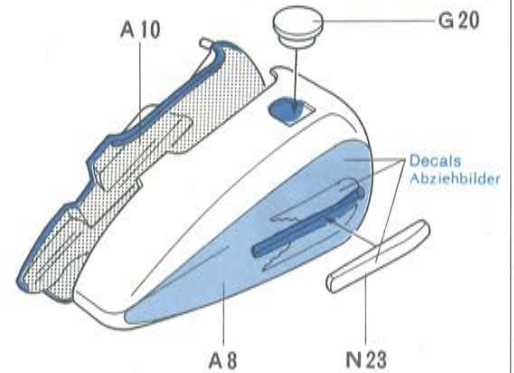

39 Fixing of Saddle Bags Einbau der Satteltaschen

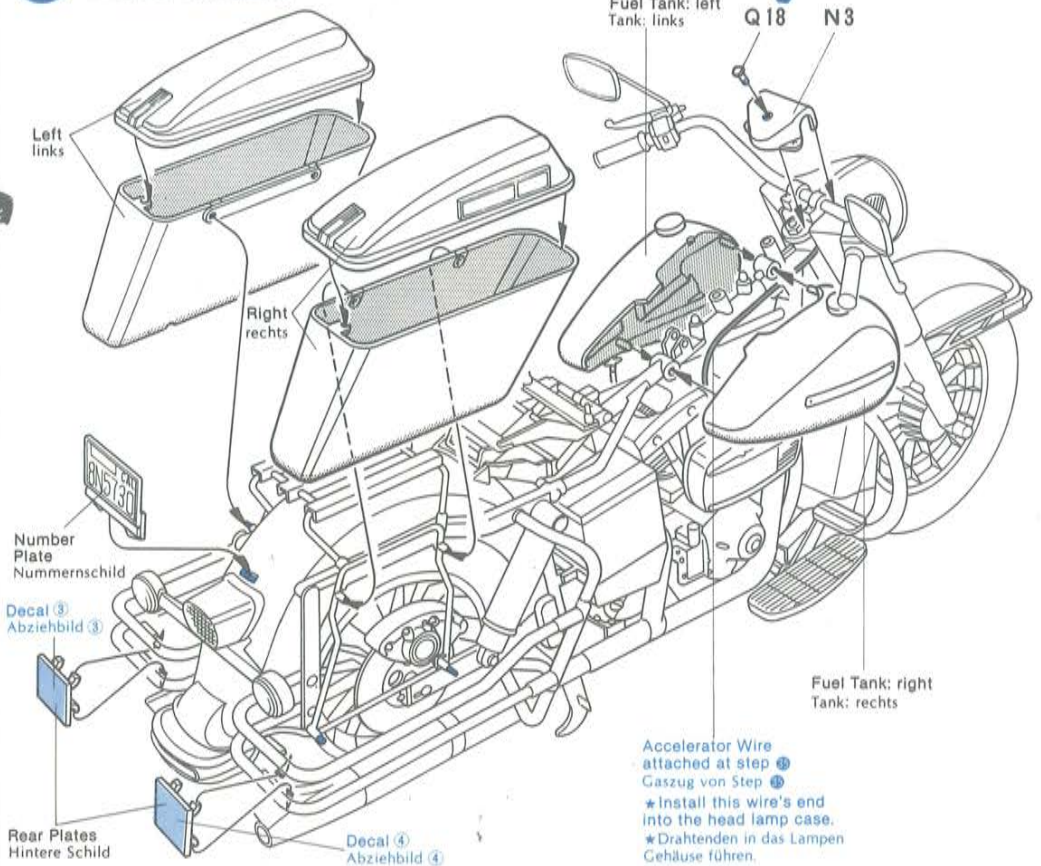

40 <<Meters>>
<<Zähler>>
<<Speedometer>>
<<Tachometer>>

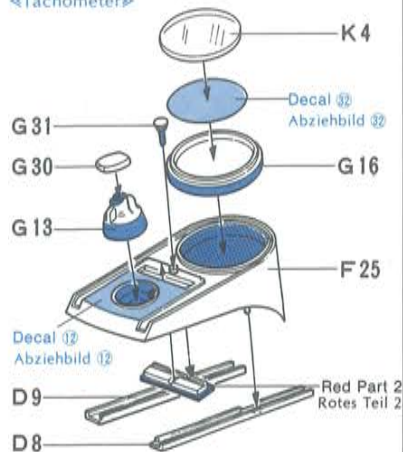

<<Decals>>
<<Abziehbilder>>

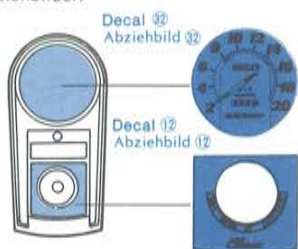

<<Combination Meters>>
<<Tacho-Kombination>>

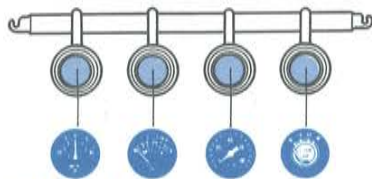

Decals: 25 26 27 28
Abziehbilder: 25 26 27 28

Decals' positions are optional.
Abziehbilder nach Wahl anbringen.

42 <<Saddle>>
<<Sattel>>



43 <<Side Lamps>>
<<Seiten-Lampen>>



40 Meters
Zähler

<<Combination Meters>>
<<Tacho-Kombination>>

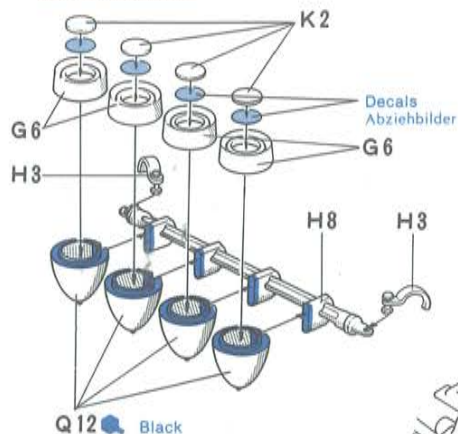

41 Tour-Pak
Sattel-Koffer

<<Step 1>>

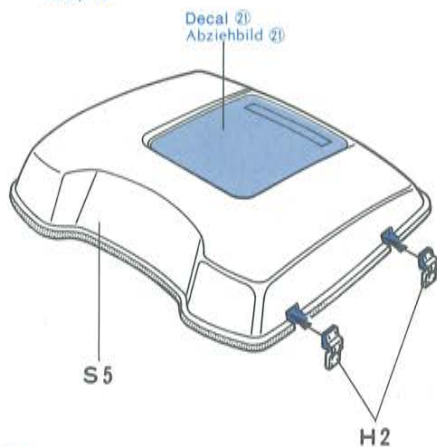

42 Saddle
Sattel

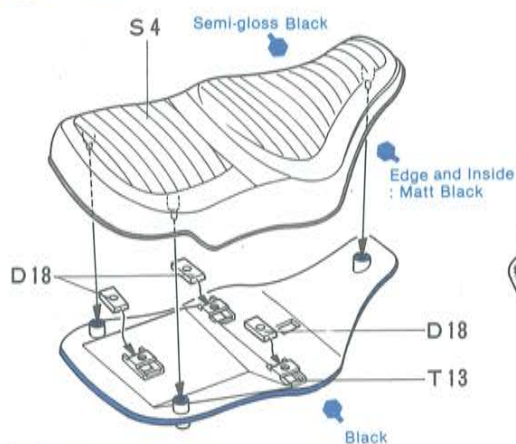

43 Side Lamps
Seiten-Lampen

<<Indicator Lamp: left>>
<<Blinklampe: links>>

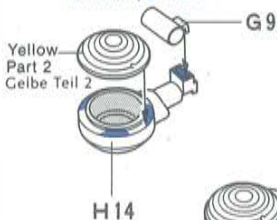

Indicator Lamp: left
Blinklampe: links

<<Left>>
<<links>>

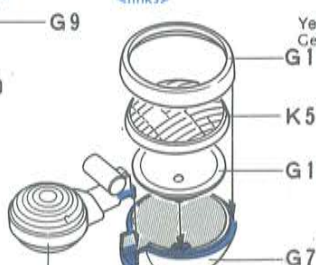

Indicator Lamp: right
Blinklampe: rechts

<<Indicator Lamp: right>>
<<Blinklampe: rechts>>

<<Right>>
<<rechts>>

<<Step 2>>

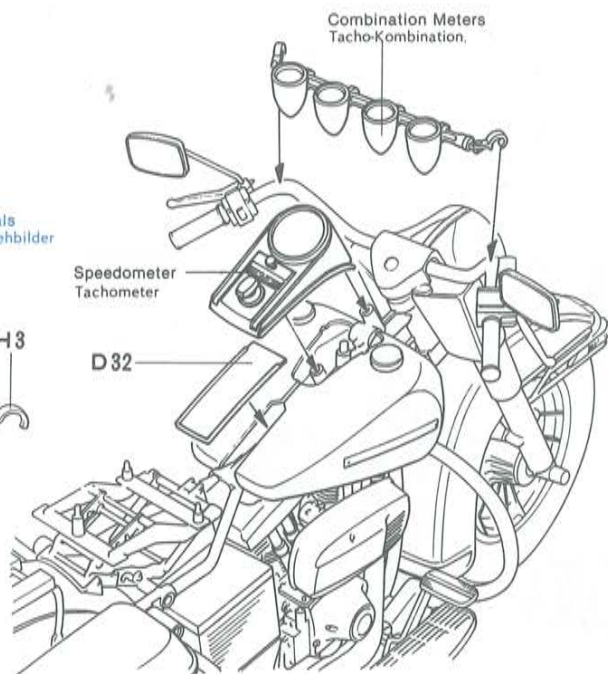
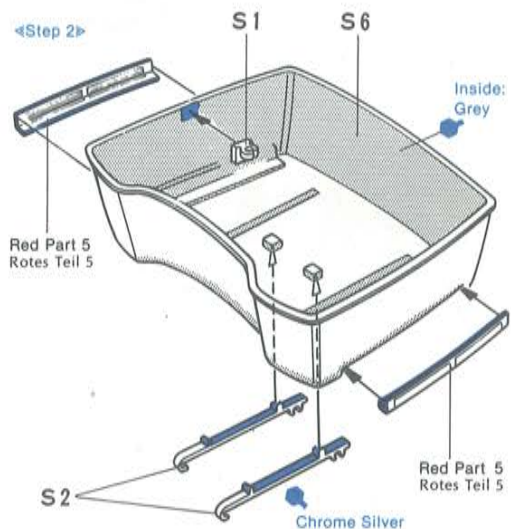

44 «Fixing of Side Lamps»
«Einbau Seiten-Lampen»



44 Fixing of Side Lamps
Einbau Seiten-Lampen

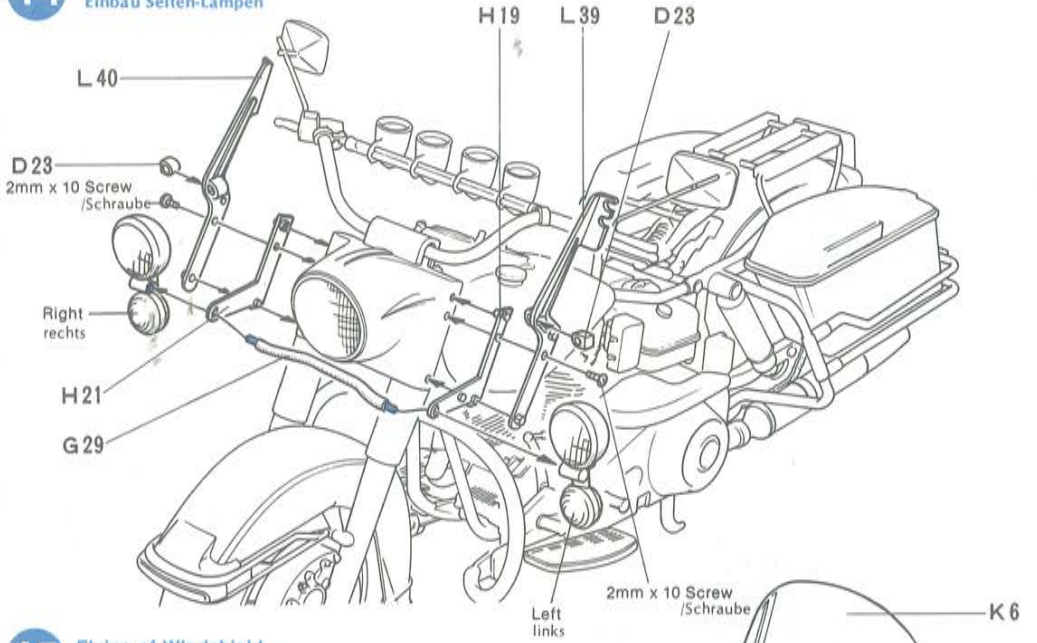

«Completion»
«Endmontage»



45 Fixing of Windshield
Einbau des Schutzschildes

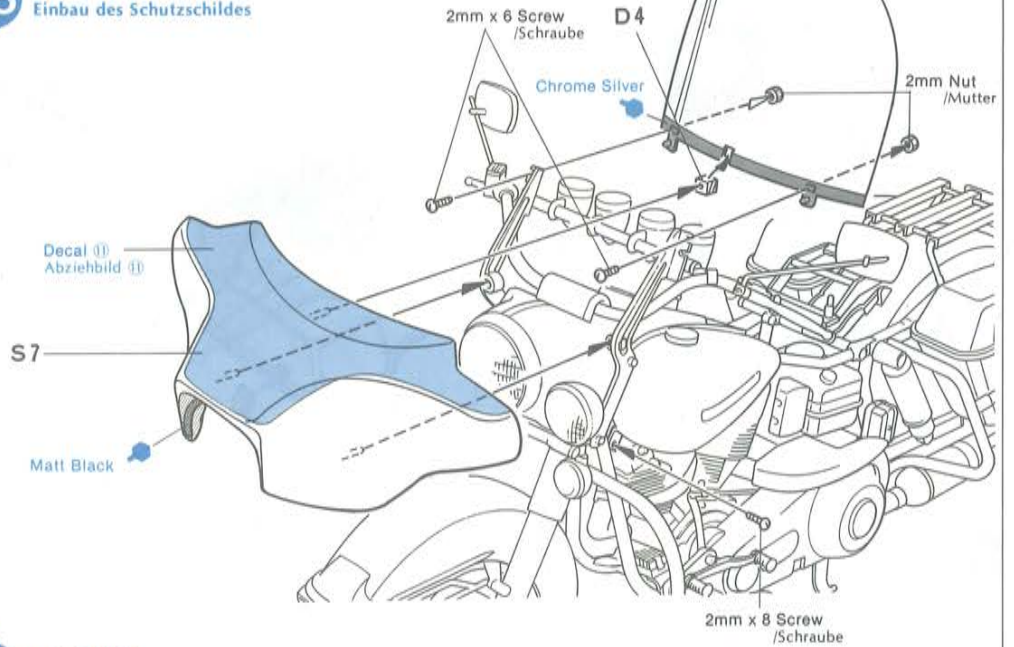

«Step Bar: right»
«Fussraster: rechts»

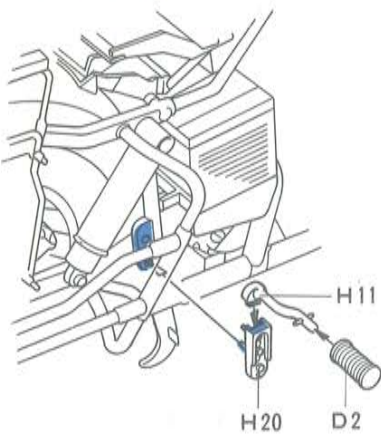

46 Completion
Endmontage

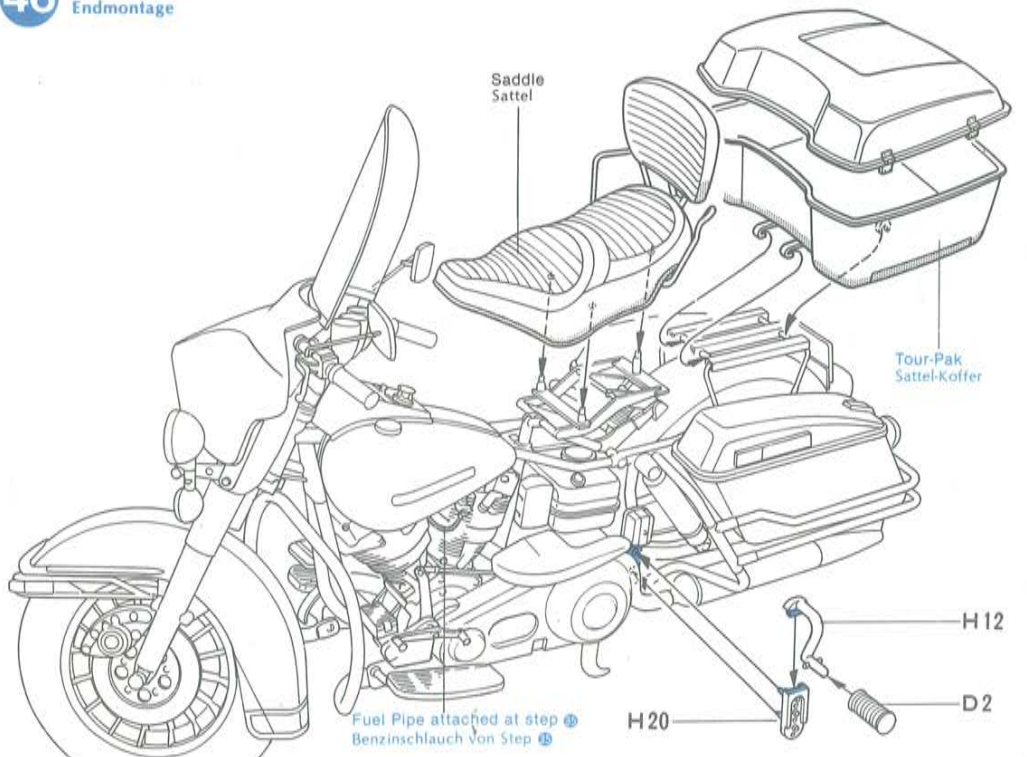

PAINTING & APPLYING DECALS

Da die Farben unter der englischen Bezeichnung zu erhalten sind, geben wir nur die englischen Namen an. **Keine Farben auf Nitro-basis verwenden!!!** Wir übernehmen keine Haftung für Schäden die durch falsche Farbenwahl entstehen. **Nur Farben verwenden, die für Polystyrol Plastik geeignet sind.**

«PAINTING»

The FLH 80 Classic is painted in classical two-tone colouring as its name implies. The kit represents the black and metallic grey model. For the black coloured sections, we recommend that you spray Clear Lacquer over the original plastic colour. Apply decals to metallic grey coloured portions. Do not spray decals with Clear Lacquer as this will adversely affect them. For painting of small parts, see the assembly drawings.

«Bemalung der FLH 80»

Der Kit ist in den klassischen Farben schwarz/grau metallic gehalten. Wir empfehlen das Modell mit Klarlack zu über sprühen. Decken Sie die grau metallic Farbe ab. Sprühen Sie niemals Abziehbilder mit Klarlack, da diese sonst brüchig werden. Kleine Teile bemalen Sie bitte der Anleitung entsprechend.

Natürlich können Sie das Modell auch immer in Ihren Farben bemalen.

«Painting»

When painting your model, remember to try and be as authentic as possible. 7 basic colours are recommended for your use. If you stick by these colours, you will convert the real aura of the actual machine.

«Bemalung»

Beim Bemalen des Modelles soll man versuchen, so genau wie möglich zu sein. 7 Grundfarben werden benötigt, für eine "echte" Harley-Davidson.

«7 Basic Colours» «7 Grundfarben»

Black
Metallic Grey
Gun Metal
Chrome Silver
Matt Black
Matt White
Aluminium Colour

«Before painting»

Remove all dust, dirt and adhesive smears before attempting any painting. Remember painting does not generally hide bad workmanship. As previously mentioned, remove excessive glue or joins with a file, sharp knife or very fine emery cloth. Most parts are best painted after assembly, but some inaccessible parts may be painted before removing from the sprue.

«Vor dem Malen»

Soll man Staub und Leimreste entfernen. Auch eine gute Bemalung verdeckt nicht schlechte Bawarbeit. Unebenheiten mit Feile oder Klinge entfernen. Viele Teile lassen sich erst nach dem Zusammenbau bemalen, jedoch die kleinen Teile bemalt man am besten am Spritzling.

«Spray Painting Hints»

Firstly always spray indoors in windless and dust-free conditions. Spread newspaper under your work. Mix the paint well by shaking the can for three minutes and then test spray against some cardboard from about 20 cm, checking that the paint is properly mixed. When spraying the body, hold the can about 20 cm from the plastic, moving the can quickly always in the same direction and ensure every application. A good tip is to imagine you are spraying a large surface, i.e. the surrounding newspaper, you will then probably achieve a more even finish.

«Bemalung mit Sprayfarben»

Nur in Zug- und staubfreien Räumen spritzen. Teile auf ausgebreitete Zeitung stellen. Spraydose gut durchschütteln (3 Min) und durch Spritzen auf Karton prüfen, ob Farben gut gemischt ist. (20 cm Abstand). Das Modell in gleicher Richtung grossflächig besprühen. Keine Sprayfarben auf Nitrobasis

sondern nur Sprayfarben für Polystyrol Plastik verwenden.

«Decal Application»

- 1 Remove all dust, dirt and adhesive smears with a wet cloth before applying any decals.
- 2 The decal to be applied should be removed beforehand from the decal sheet. Cut off translucent films along coloured parts.
- 3 Dip the decal in tepid water for about 10 seconds and then remove it onto a clean cloth. Be careful of over immersion to avoid loss of decal's adhesive.
- 4 Hold the backing sheet edge and slide the decal onto the model.
- 5 Wet the decal with a little water on your finger so that it can be moved more easily into position.
- 6 Press the decal down gently with a clean soft cloth to remove air bubbles and until all excess water has been fully absorbed. When a decal has to be applied to a surface which is uneven or curved, press the decal down with a hot towel so that the decal will fit the contours perfectly. Cut off the ex-

cess transparent portion around each decal. The decal must then not be touched until dry.

«Abziehbilder-Decals»

- 1 Staub, Schmutz und Klebstoffreste mit nassem Tuch entfernen.
- 2 Decals erst ausschneiden entlang den Linien.
- 3 Decals in Wasser legen, dann nach 10 Sekunden auf z.B. Handtuch legen und etwas abtrocknen lassen.
- 4 Decal an der Unterlage halten und Bild auf das Modell schieben.
- 5 Mit etwas Wasser auf dem Finger lässt sich das Decal noch etwas verschieben.
- 6 Decal mit etwas Stoff gut andrücken um die Luftblasen zu entfernen und das Wasser abzutrocknen. An unebenen Stellen kann man mit heissem Tuch das Decal besser andrücken. Transparente Überreste am Decal abschneiden. Decal nicht mehr berühren, bis getrocknet ist.

«Decals» «Abziehbilder»

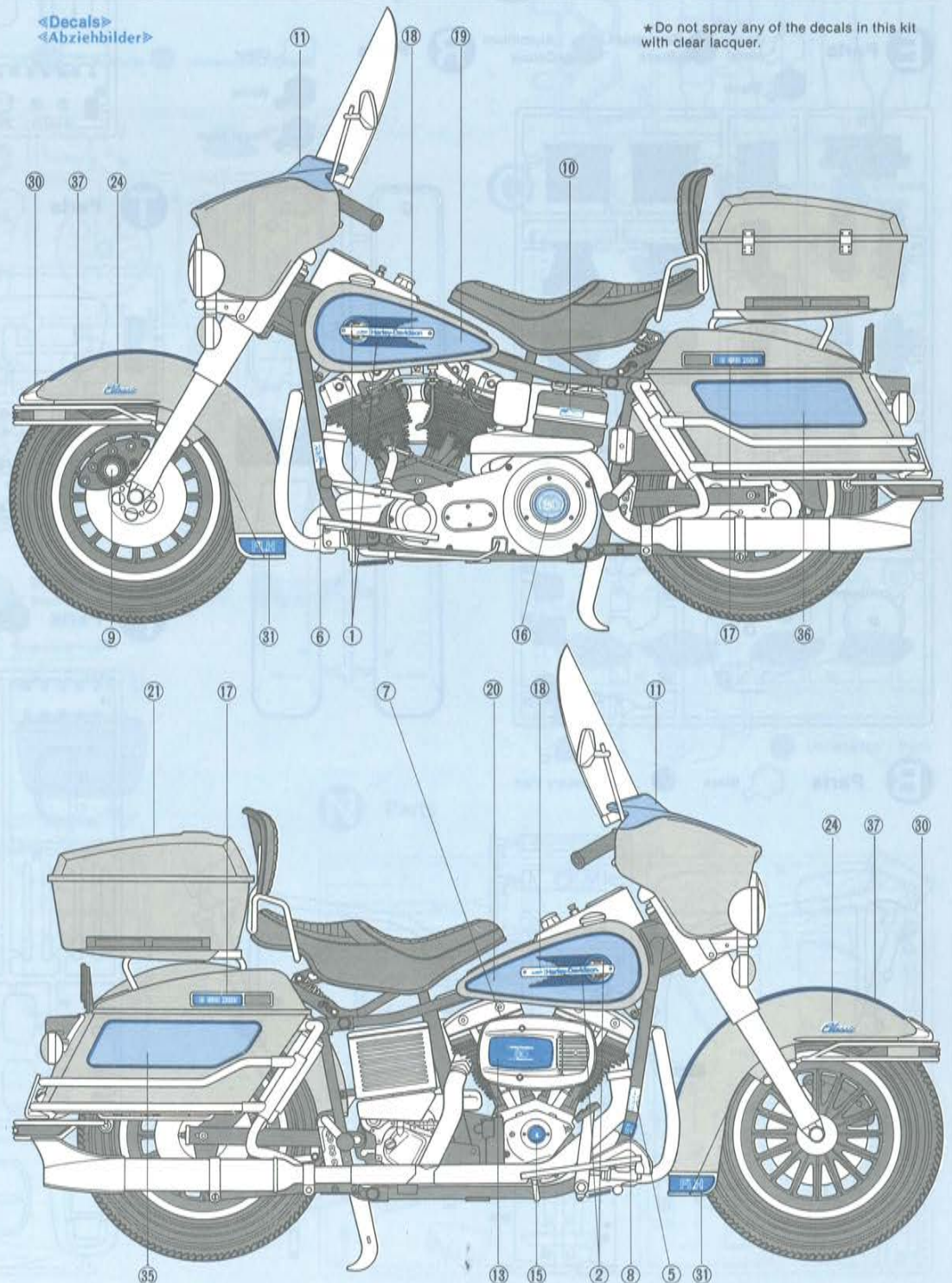

* Do not spray any of the decals in this kit with clear lacquer.

PARTS

A Parts Clear

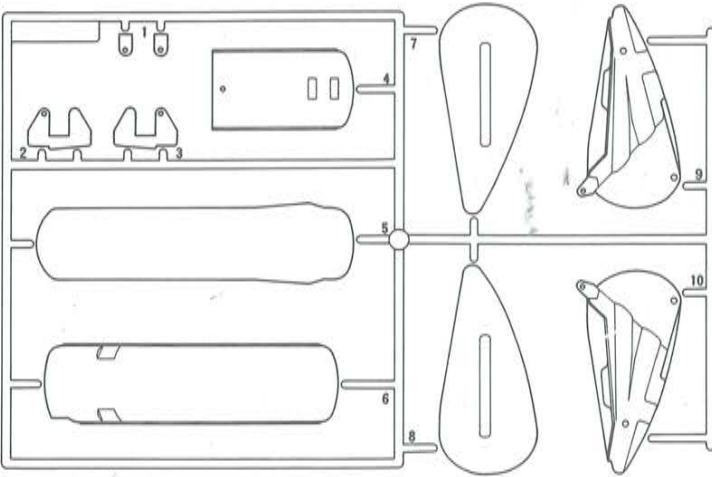

C Parts Black Gun Metal Chrome Silver

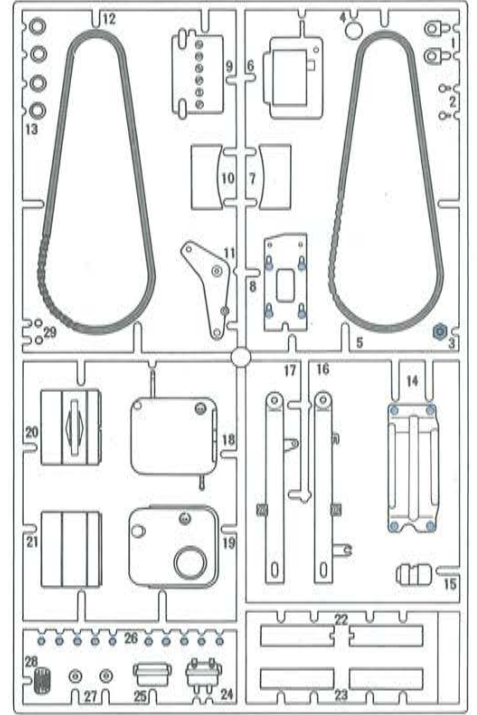

E Parts Gun Metal Semi-gloss Black Aluminium Colour Black

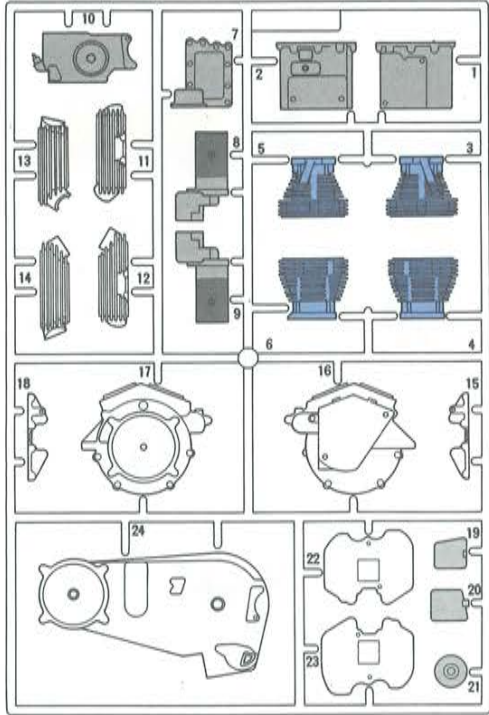

R Parts Clear White Royal Blue

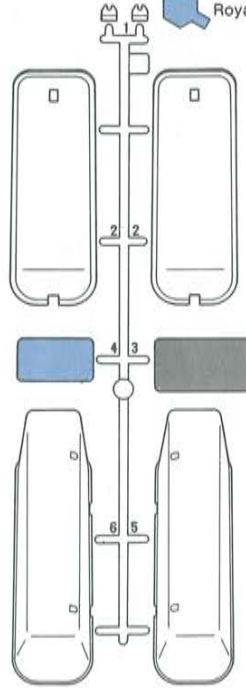

T Parts Black Chrome Silver

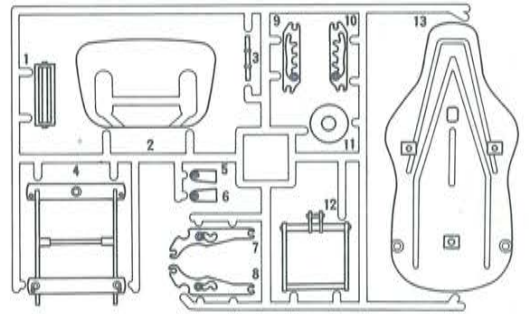

F Parts Matt Black

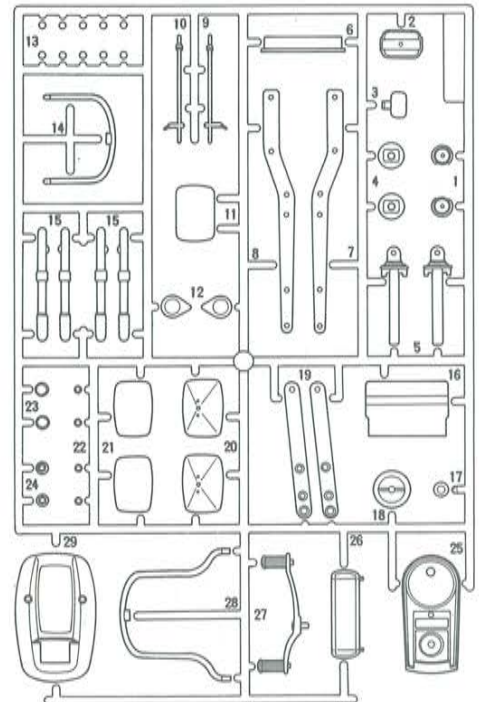

B Parts Black : Unnecessary Part

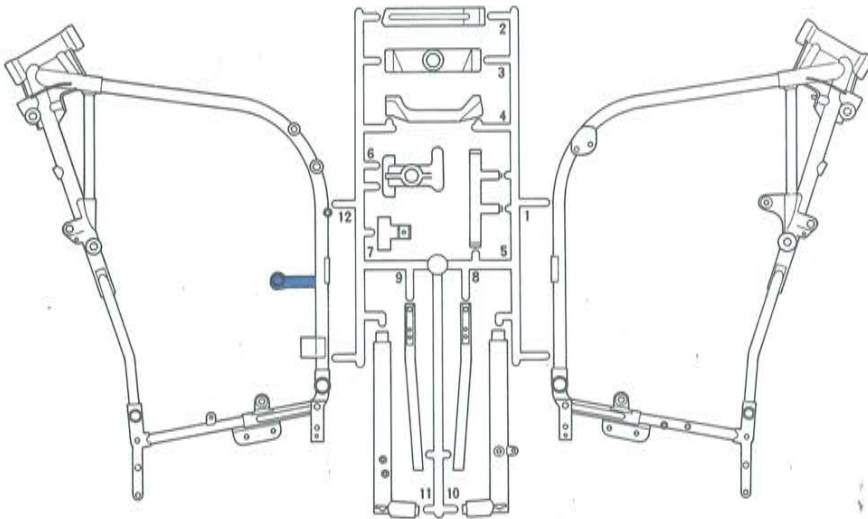

PARTS

G Parts

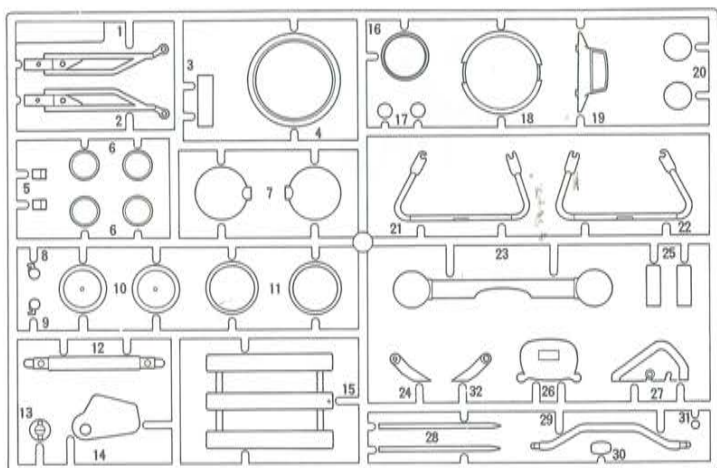

L Parts

Matt Black
 Gun Metal
 : Unnecessary Parts

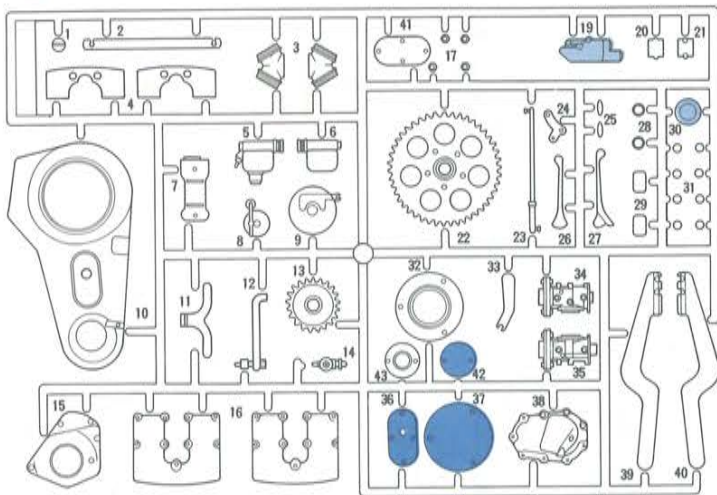

S Parts

Clear
 Semi-gloss Black
 Matt Black
 Chrome Silver

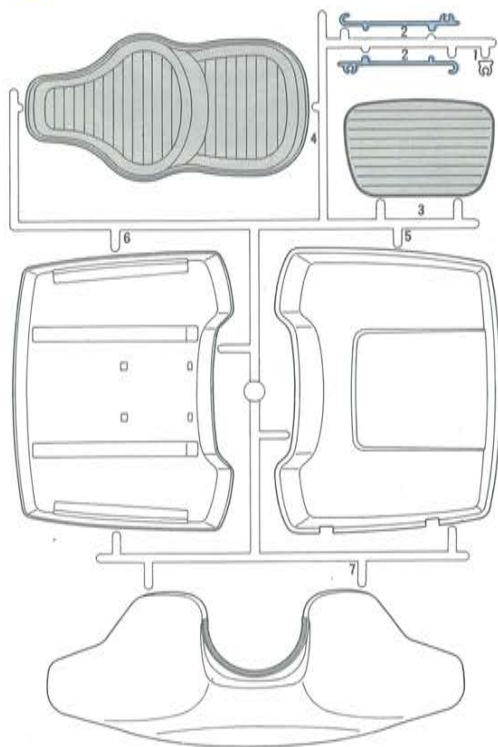

H Parts

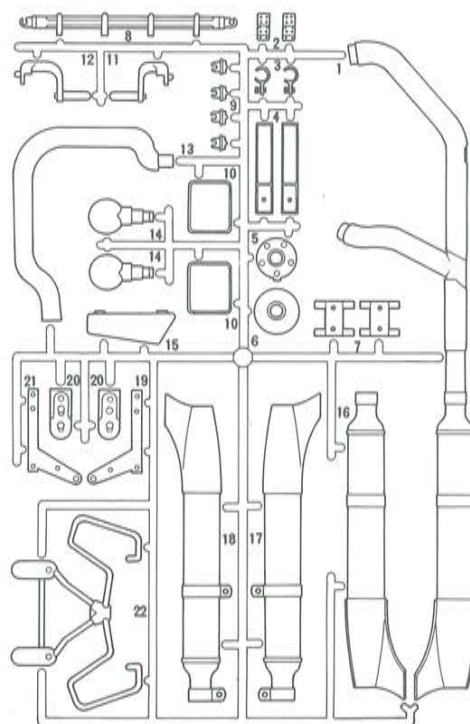

C Parts

Black
 Semi-gloss Black
 Chrome Silver

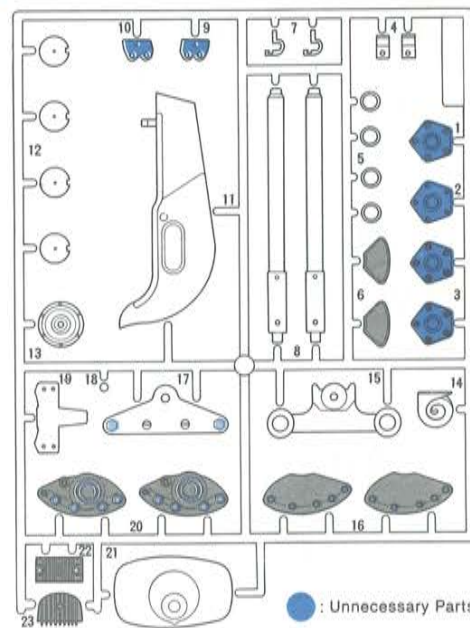

N Parts

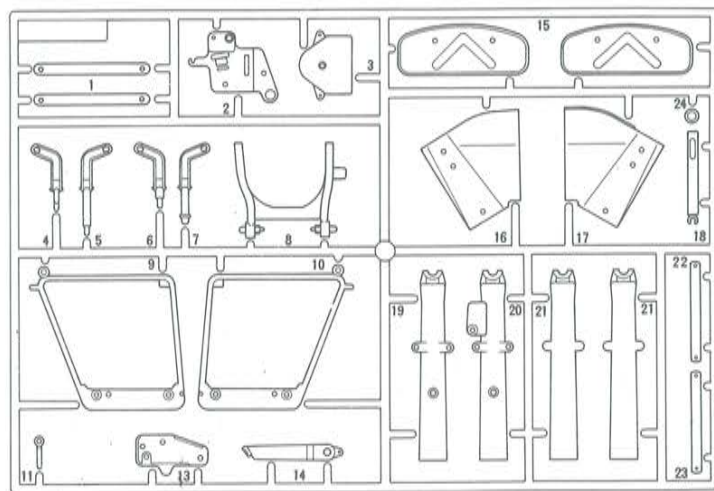

PARTS

P Parts

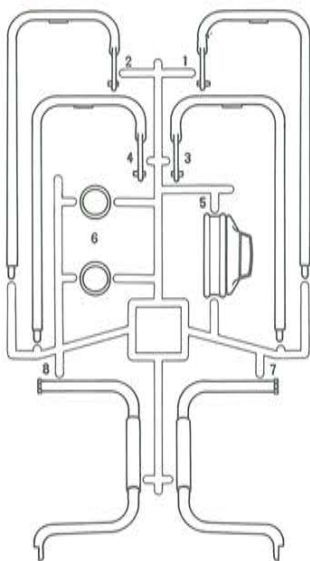

★ Decal

D Parts

● : Unnecessary Part

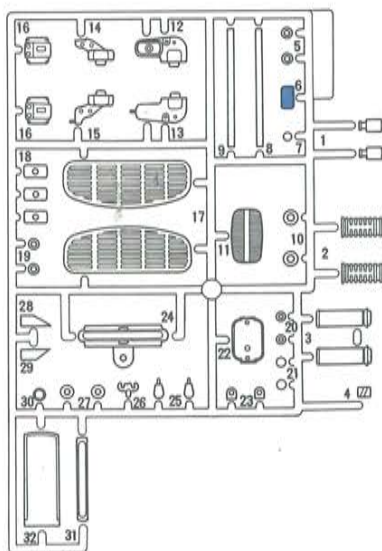

J Parts

■ Semi-gloss Black

Front Wheel

Rear Wheel

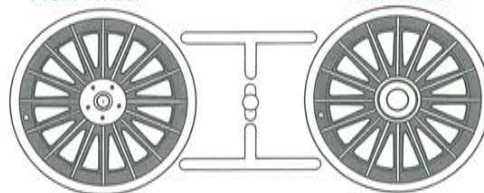

K Parts

■ Chrome Silver

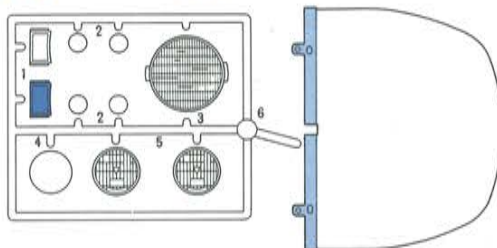

M Parts (in Blister Pack)

Thick Vinyl Pipe
Thin Vinyl Pipe

■ White

Yellow Parts

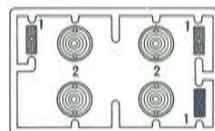

Red Parts

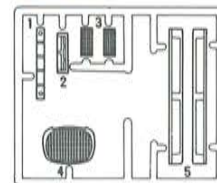

BUILD A COLLECTION OF TAMIYA
PRECISION MOTORCYCLE MODELS

KAWASAKI KZ1300B TOURING



HONDA CB1100R



SUZUKI GSX1100S KATANA



HONDA CX500 TURBO

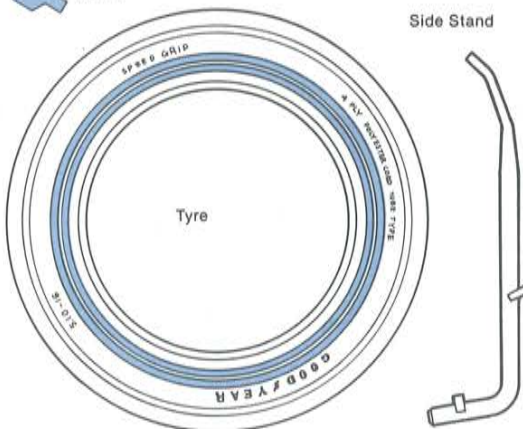

Side Stand

Rear Damper Boot

Handle Bar

Battery Cover

Safety Guard

Exhaust Pipe Cover



Brake Disc

◀Spring Bag▶
(full size)



Spring A



Spring B



Spring C

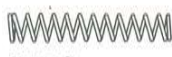

Spring D



Spring E

◀Screw Bag▶ (full size)

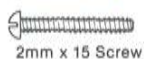

2mm x 15 Screw

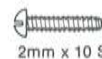

2mm x 10 Screw



2mm x 8 Screw



2mm x 6 Screw



2mm Nut



Rear Wheel Shaft

TAMIYA
TAMIYA PLASTIC MODEL CO.
3-7 ONDWARA, SHIZUOKA-CITY, JAPAN