

Kawasaki Z1300

1:6 SCALE

SUPER DETAILED KAWASAKI D.O.H.C. SIX ENGINE
MOVABLE FRONT AND REAR SUSPENSION
SUPER DETAILED SEMI-PNEUMATIC RUBBER TYRES
DETACHABLE SIDE COVERS

BIG SCALE 19



TAMIYA

TAMIYA PLASTIC MODEL CO.
3-7 ONDAMARA, SHIZUOKA-CITY, JAPAN

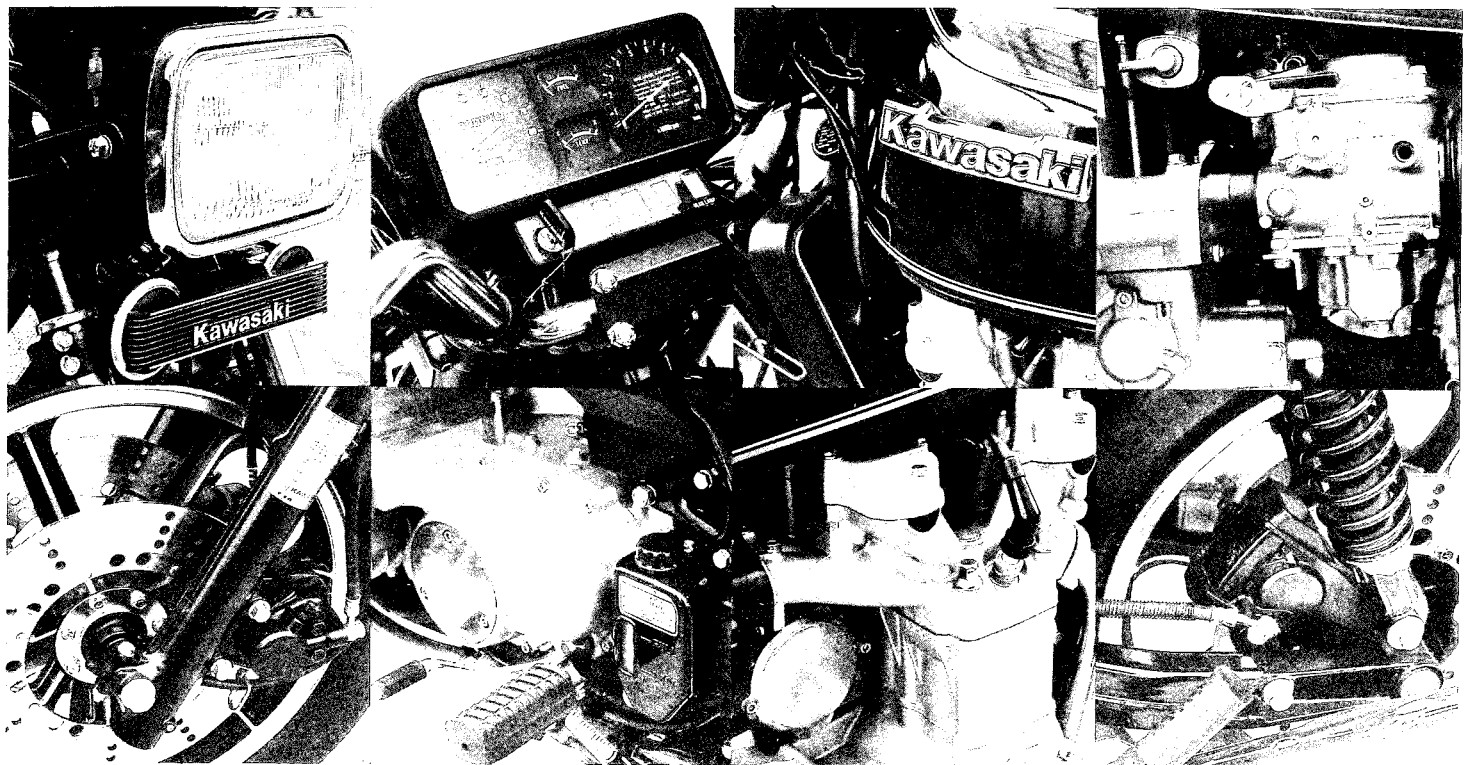

Kawasaki Z1300

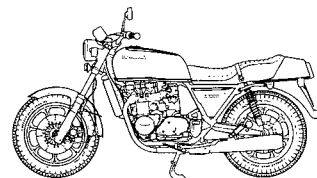

With more than five years in development the Kawasaki Z1300 motorcycle is fast becoming the standard which other manufacturers hope, eventually, to emulate. The magic of this machine is that it is so capable on the road. It is rock steady and as stable as parked greyhound bus. This is a touring bike of the first magnitude and one engineered from the start, with the user in mind. Kawasaki has indeed produced another masterpiece. The outstanding handling qualities of the Z1300 have astonished many reviewers, who had been ready to expect some difficulties in such a large and powerful bike. It is an amazingly well balanced, exceptionally comfortable bike, yet retains the distinctly Kawasaki sporting heritage. Sophistication shows throughout the bike. The engine has a silent cam chain with an automatic tensioner. Full transistorized ignition system and halogen headlamp are a revelation in motorcycle lighting. Their new sintered metal brake pads work virtually as well wet or dry, and the drilled stainless steel brake discs are silent. The Z1300 engine will match the design and engineering sophistication of some of the finest cars in the world. The double overhead cam system has long been the choice of all leading European engine manufacturers, and this engine is exceptionally efficient, producing over 92hp per litre. Many 1 litre cars fail to produce half this amount of power. Watercooling was chosen because the double jacketing can be made more compact than adequate finning would require. Cooling efficiency is much higher and more even, and the extra layers around the cylinders muffle the combustion noise, so that the engine is unusually quiet. In fact at cruising speed it is usually inaudible. The six cylinders eliminate the vibration of lesser engines, so unparalleled smoothness is obtained. The entire power train is equally sophisticated, as four separate shock absorbers and a drive shaft are employed in its mounting.

As you might well imagine, this Z1300 is a large, powerful and expensive bike. The sheer weight, power and expense will make possible its ownership by only a

few; however, those few will possess a motorcycle unsurpassed in quality, sophistication and most importantly, road handling. Its six cylinder, four stroke, watercooled engine has a cubic displacement of 1,286cc, and utilizes an electric starter, and a wet sump forced lubrication system that is the equal of any high performance car on the market. It has a maximum horsepower of 120 at 8000 rpm. Its 5 speed, constant mesh, return shift transmission has a final reduction ratio of 4.545 to 1, which provides a top speed of 225kph. This big bike will move from a standing start to 1/4 mile in 11.7 seconds. It has a minimum turning radius of 2.8 meters. The frame is of the double cradle type, constructed from tubular steel. Front suspension is with the usual oil filled telescopic fork, and rear is swing arm type. Braking is via two front discs with an effective disc diameter of 260mm and with a single 250 mm disc in the rear. The Z1300 has a 12 volt electrical system, with current supplied from a 20Ah wet cell battery. Overall length is 2,335 mm, and width is 840mm. Height is 1,155mm and the dry weight is 296kg. Curb weight front: 154kg and rear 172kg. Fuel tank capacity is 27 litres.

The Kawasaki Heavy Industries first ventured into the big motorcycle field in 1966 when they released their W-1, which was a 650cc 4 cycle bike, but they came into prominence in the motorcycle field with the Kawasaki 500SS Mach III. It was a three cylinder 500cc two stroke machine with a top speed of 200km/h, and became widely known throughout the world in the late 1960's and established Kawasaki as a viable producer of high performance bikes. In 1974 they released the 900Z1 at about the same time as the Honda Gold Wing GL1000 was unveiled. Kawasaki was already thinking about a bigger project at this time, under the code number 203, which was the prototype for the Z1300. It is reported that Kawasaki originally called for a 1200cc displacement, six cylinder engine, but when the Honda CBX1000 and the Harley Classic with 1340cc became known, Kawasaki altered the plans and drew up specifications for

a six cylinder 1300cc engine for Code No. 203. As the entire motorcycle industry was moving quickly with new features and powers, and as the state of the art improved, Kawasaki continually added and upgraded the development of the Z1300, until at the time of its release, the Z1300 contains virtually every new state of the art feature for motorcycles, and for many years to come, those features will be seen on bikes produced world wide. Yes, Kawasaki Heavy Industries have done their homework on the Z1300.

In the past we have had the "Prince" of bikes; the "King" of bikes, and now with the advent of this superbike, Kawasaki's superb masterpiece Z1300 is surely the "Emperor" of bikes.

* * *

Über fünf Jahre dauerte die Entwicklung der Kawasaki Z1300. Dieses Motorrad wurde erreichte einen Standard, den andere Hersteller gerne erhoffen, ja sogar nacheifern möchten. Der Zauber dieser Maschine liegt in der Leistungsfähigkeit auf der Strasse. Es ist ein Touring-Rad erster Grösse und gebaut unter Beachtung und Berücksichtigung der Fahrerwünsche. Kawasaki hat tatsächlich ein neues Meisterstück entwickelt. Die aussergewöhnliche Handhabung der Maschine hat sehr viele Betrachter in Erstaunen versetzt, denn es wurden erst einige Schwierigkeiten aufgrund der Grösse und Stärke erwartet. Erstaunlich ist die Ausgewogenheit und der Komfort der Maschine, die trotzdem die sportlichen Eigenheiten der Kawasaki's in sich hat.

Der Motor hat eine ruhige Nockenkette mit automatischem Spanner. Volle Transistorzündung und Halogen-Scheinwerfer. Die neuen, gesinterten Bremsbacken arbeiten einwandfrei ob trocken oder nasse Fahrbahn, die Stainless Bremstrommeln sind sehr ruhig. Der Z1300 Motor kommt an die Technik mancher Automotoren heran. Die doppelte, obenliegende Nockenwelle—seit vielen Jahren in europäischen Motoren—bringt den Motor auf eine Leistung von über 92 PS per Liter. Wasserkühlung wurde gewählt, da diese Kühlung wesentlich grösser ist. Die Zylinder Auspuffstutzen wurden so verändert, dass der Auspuff fast unhörbar ist. Man kann erkennen, die Kawasaki Z1300 ist eine grosse, starke und teure Maschine und die wenigen Besitzer werden ihre Freude daran haben.

Sechs Zylinder, 4-Takt, wassergekühlter Motor mit 1286 cc, Elektro-Starter und Ölschmierung—fast schon ein Auto—bringen max. 120 PS bei 8000 Umdrehungen und 225 Km/Stde. Der Wendekreis ist 2,8 Meter. Der Rahmen ist aus Stahlrohr. Die Vorderradgabel ist eine ölgefüllte Telescopgabel und hinten hat die Maschine einen Schwingarm. Die zwei vorderen Brems scheiben haben einen wirken Drechmesser von 260 mm, die hintere, 250 mm. Die Spannung hat 12 Volt, die Batterie 20 Ah.

Gesamtlänge ist 2,335 m, Breite 0,840 m, Höhe 1,155 m. Gewicht 296 Kilo, der Tank fasst 27 Liter.

In der Vergangenheit hatten wir den "Prince" der Motorräder, den "König" der Motorräder und jetzt hat Kawasaki mit der Z1300 bestimmt den "Emperor" der Bike's.

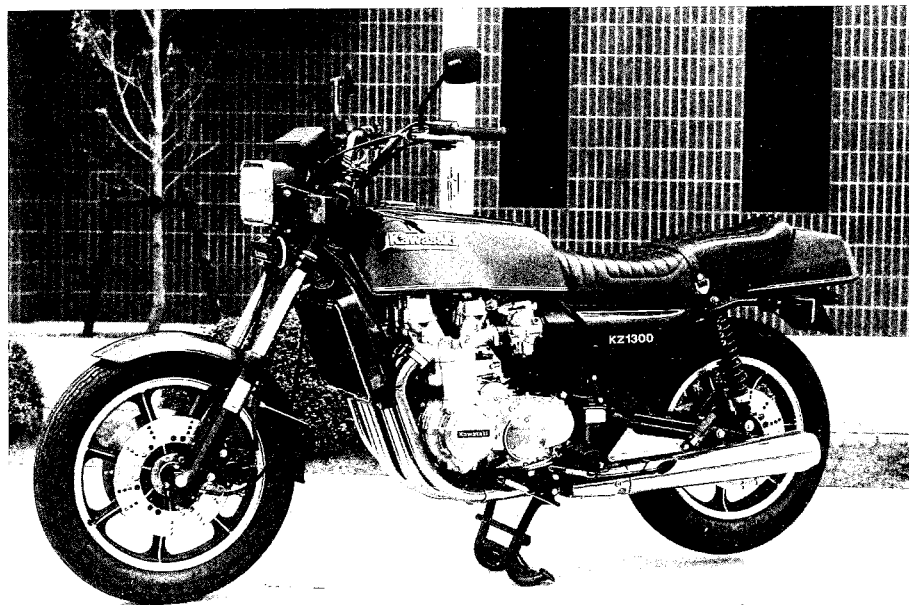

Read before assembly
Erst lesen -
dann bauen



- *Study the instructions and photographs before commencing assembly.
- *You will need a sharp knife, a screwdriver, a file and a pair of pliers.
- *Do not break parts away from sprue, but cut off carefully with a pair of pliers.
- *Use cement sparingly. Use only enough to make a good bond.
- *Apply cement to both parts to be joined.
- ☉ This mark shows the colour.

*Vor Beginn die Bauanleitung studieren und den Nummern nach die Elemente zusammenbauen.

- *Bauteile nicht vom Spritzling abbrechen, vorsichtig abschneiden oder abwickeln. Teil vor Kleben zusammenhalten, auf genauen Sitz achten. Nicht zuviel Klebstoff verwenden. Kleine Teile hält man mit Pinzette fest.
- *Abziehbilder vorsichtig von der Unterlage im Wasser abschieben, auf richtigen Sitz achten und gut trocknen lassen.
- ☉ Zeichen für Bemalung.

☉ : Parts to be cemented
☉ : hier ankleben

☉ <Frame A>
☉ <Rahmenbau A>



PAINTING

<Timing of Painting>

Parts to be painted in the same colour should be painted after being assembled. This is the tip for gaining the best result. Parts with adhesives forced out and loosened seams should be filed before painting. Direct your attention even to the smallest screw.

Teile die in gleicher Farbe bemalt werden, sollten nach dem Kleben bemalt werden. Vor dem Bemalen die Klebstoffreste entfernen. Auch auf das kleinste Detail achten.

<Painting of Frame>

Paint black parts in black. Frame should be carefully painted one side at a time so as not to leave finger mark.

<Bemalung des Rahmens>
Alle schwarzen Teile in schwarz bemalen. Zuerst eine Seite so lassen sich Fingerdrücke vermeiden.

1 Frame Assembly 1
Rahmenbau 1
<Center Frame>
<Rahmen-Mittelteil>

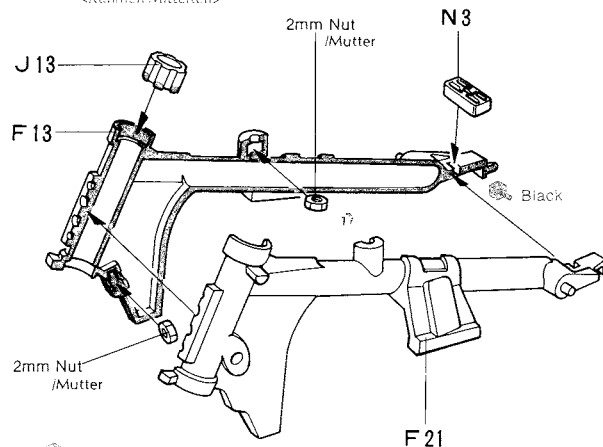

☉ Paint all bolts Chrome Silver
Alle Bolzen sind chrome sorgfältig bemalen.

☉ Semi Gloss Black =
Black:1 + Matt Black:1

<Frame B>
<Rahmen B>

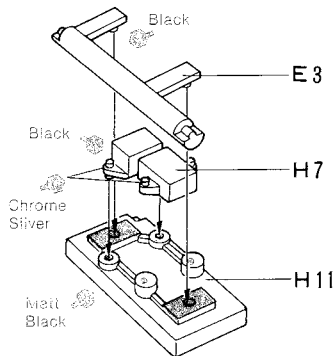

<Frame A>
<Rahmen A>

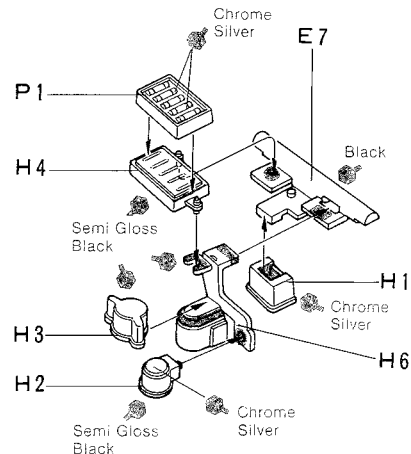

<Ignition Coil>
<Zündspule>

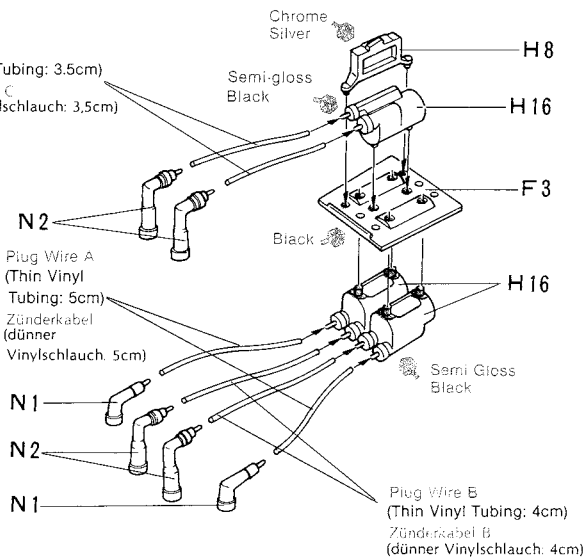

2 Frame Assembly 2
Rahmenbau 2

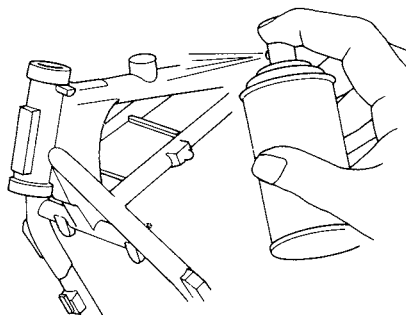
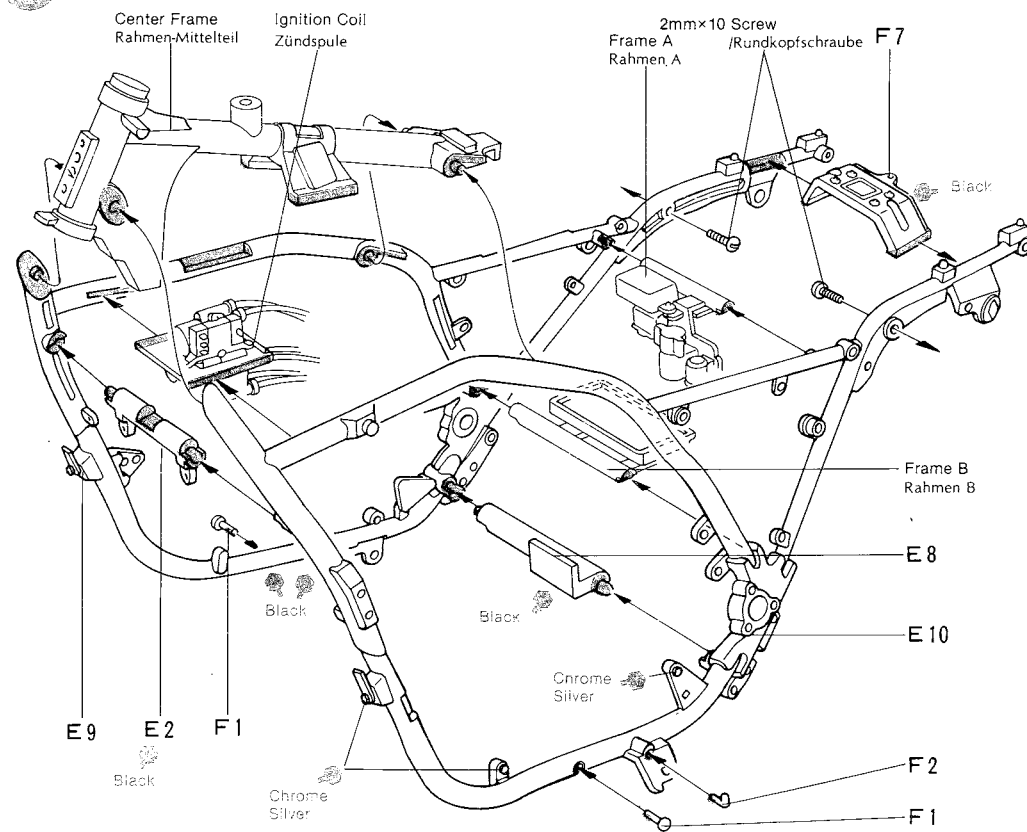

3 <<Assembly of Main Frame>>
<<Zusammenbau des Ständer>>

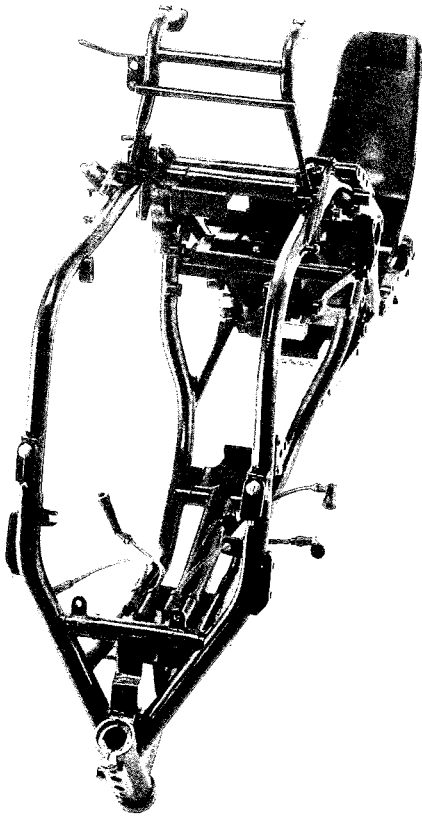

3 Assembly of Main Frame
Zusammenbau des Ständer

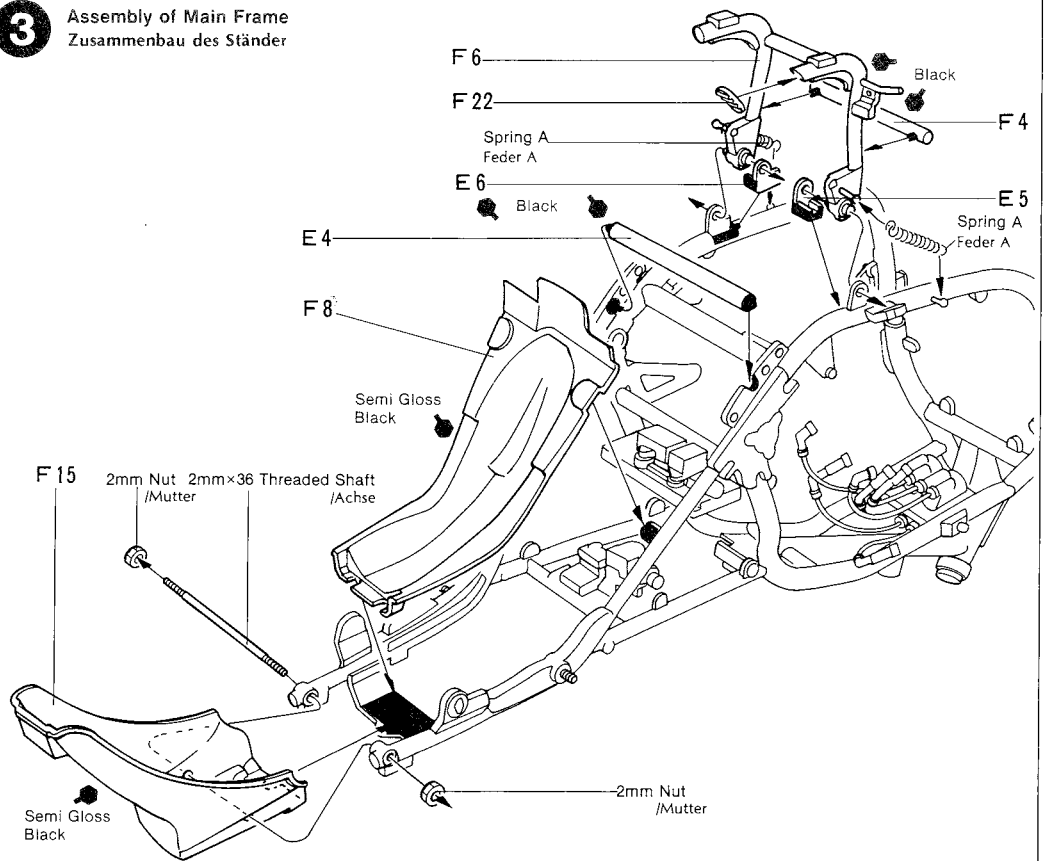

4 <<Assembly of Crank Case>>
<<Montage des Kugelgehäuse>>

<<Cementing Plated Parts>>
<<Das Kleben verchromter Teile>>
Before cementing plated parts, remove plating with a knife, etc. from the surface to which cement is applied.
Chromschicht an klebstellen entfernen.

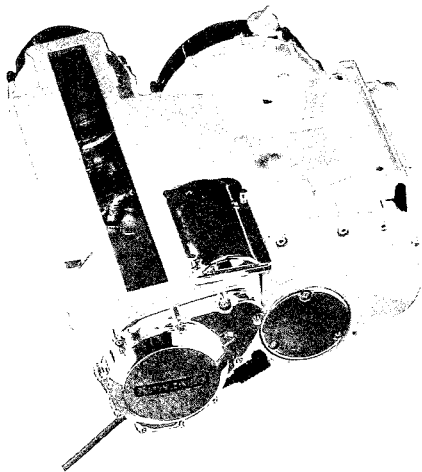
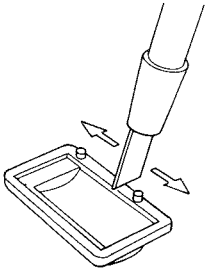

4 Assembly of Crank Case
Montage des Kugelgehäuse

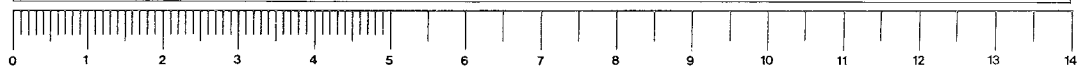
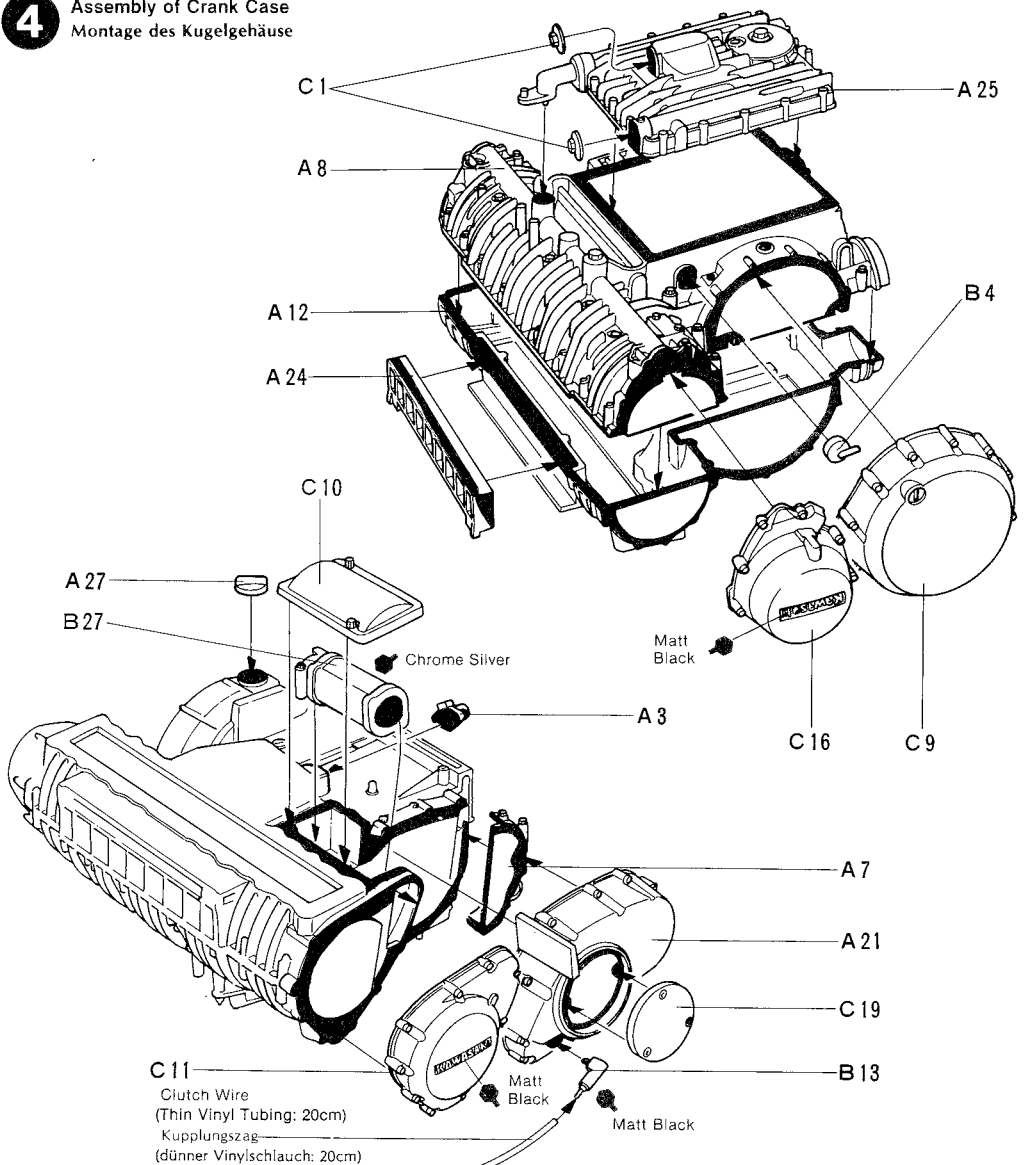



<Placing Crank Case into Frame>
<Einbau Kugelgehäuse in Rahmen>

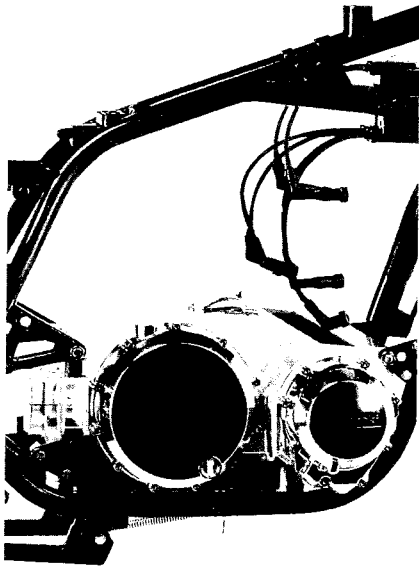

<Assembly of Air Cleaner>
<Luftfilter>

It is recommended to hold tubing with tweezers when attaching it.
Vinylschlauch hält man mit Pinzette.

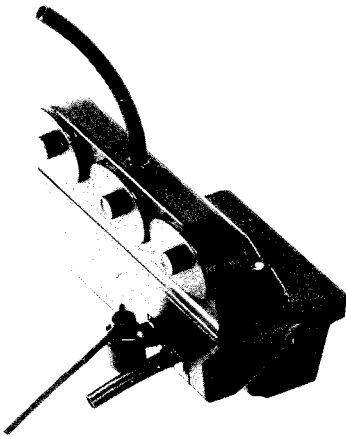
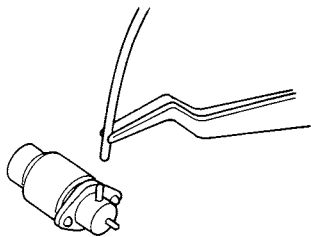

PARTING

Parts to be painted the same colour should be painted after being assembled.
Teile die in gleicher Farbe bemalt werden, sollten nach dem Kleben bemalt werden.

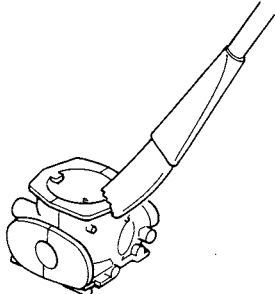

<Placing Crank Case into Frame>
<Einbau Kugelgehäuse in Rahmen>

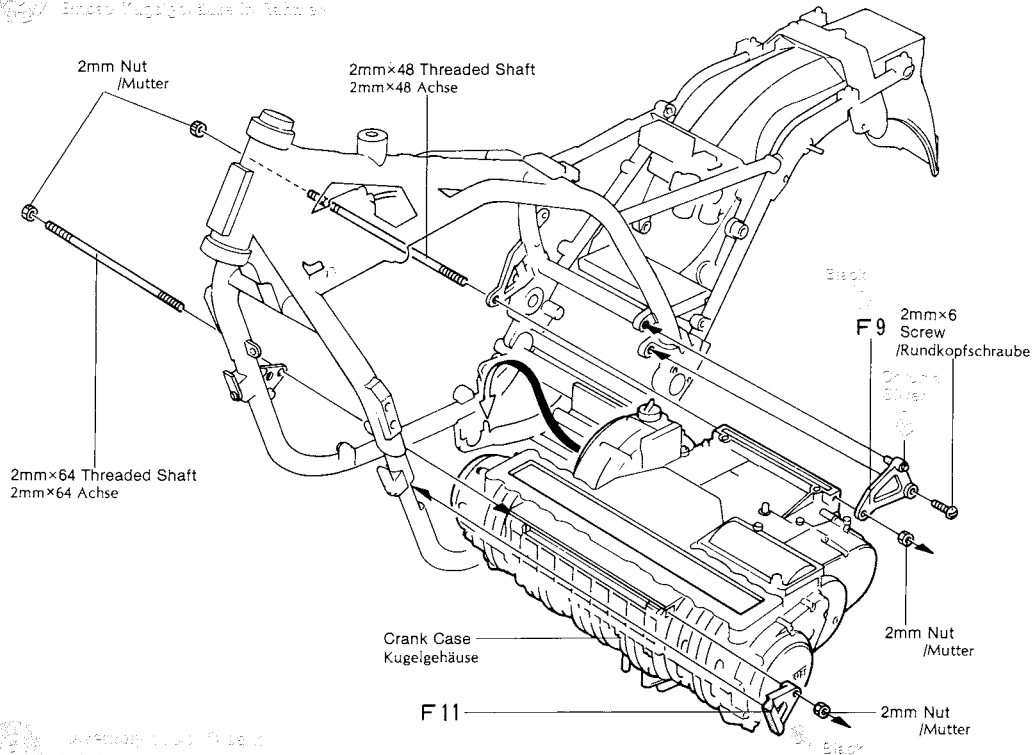

<Assembly of Air Filter>
<Luftfilter>

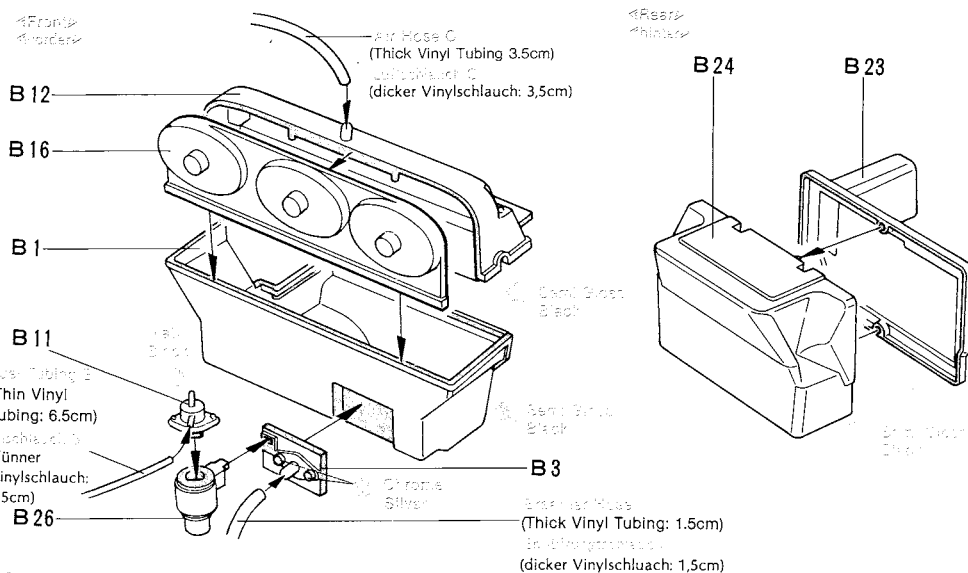

<Assembly of Air Cleaner>
<Luftfilter>

A clean product air cleaner first.
Vor dem Einbau des Luftfilters reinigen.

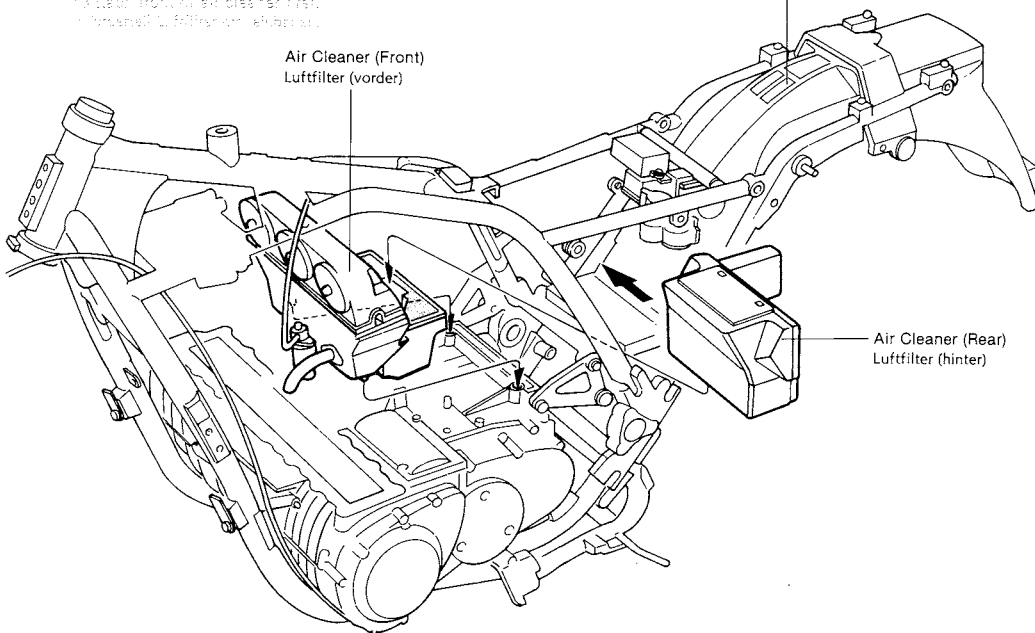

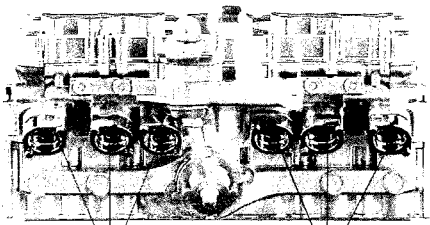

Note the direction.
Auf Richtung achten.

Note the direction.
Auf Richtung achten.

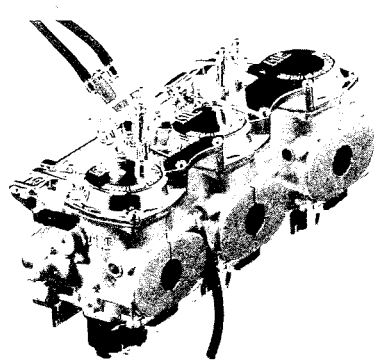
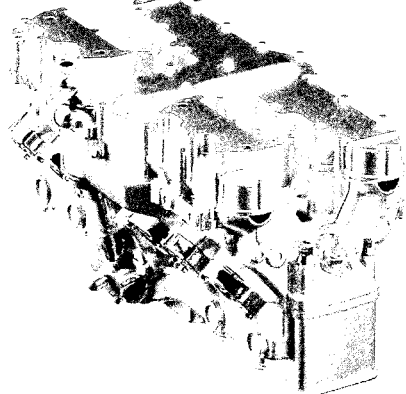
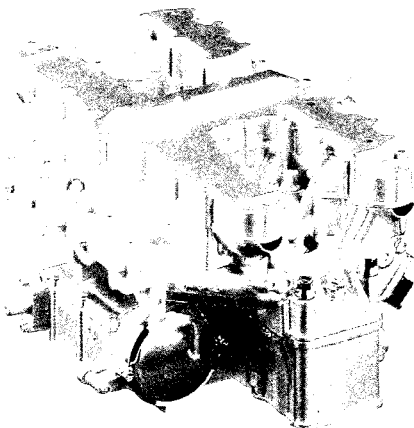

All the bolts used in the frames and the engine are chrome plated. Paint them with care, since they serve to enhance the overall appearance of your finished model.

Alle Bolzen im Rahmen und Motor mit chromesorgfältig bemalen. Sie erreichen dadurch ein besseres Aussehen des Modelles.

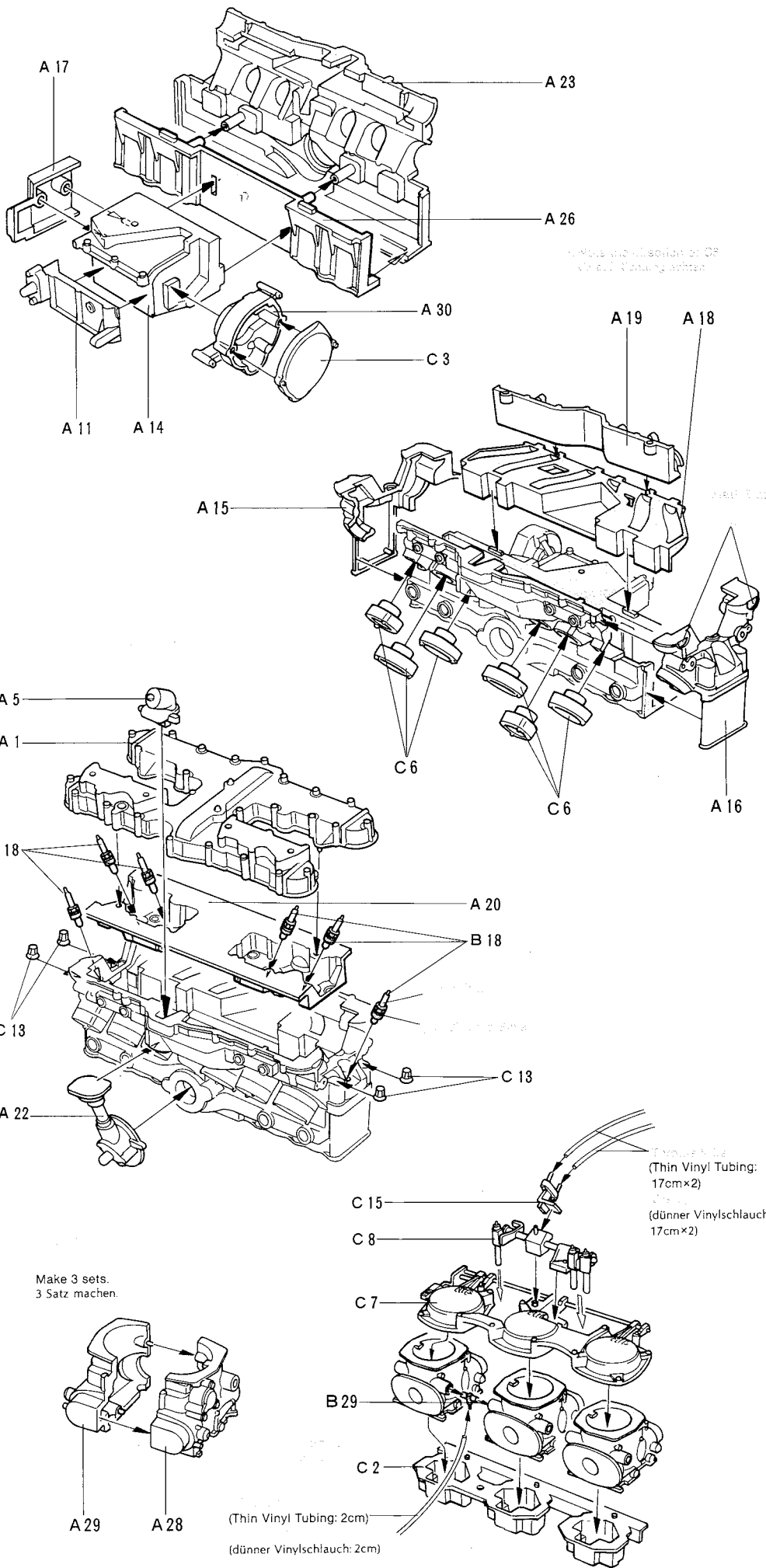
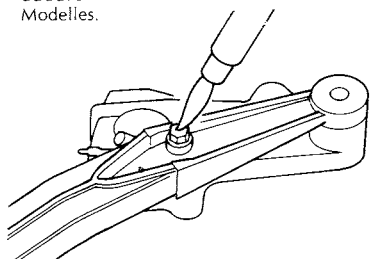

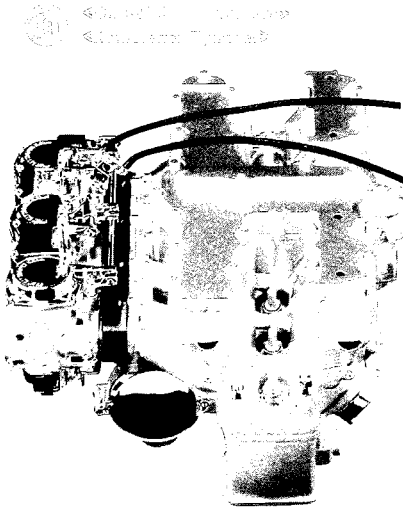

◀Mount of Cylinder▶
◀Hauptlager Zylinder▶

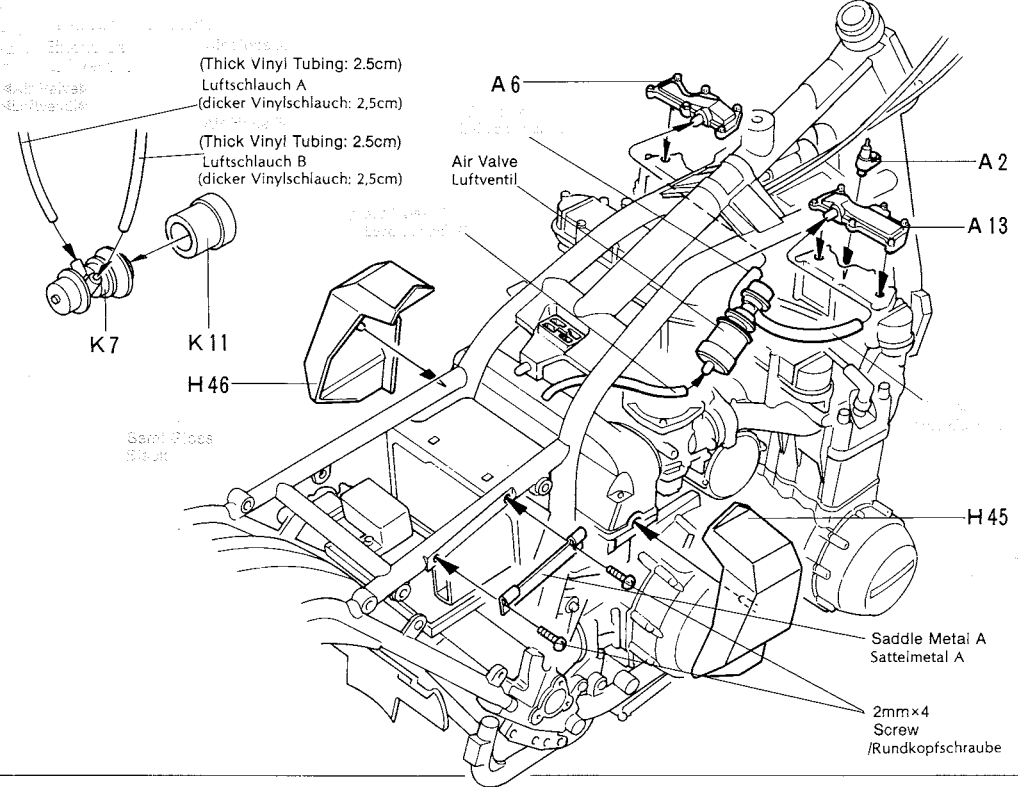
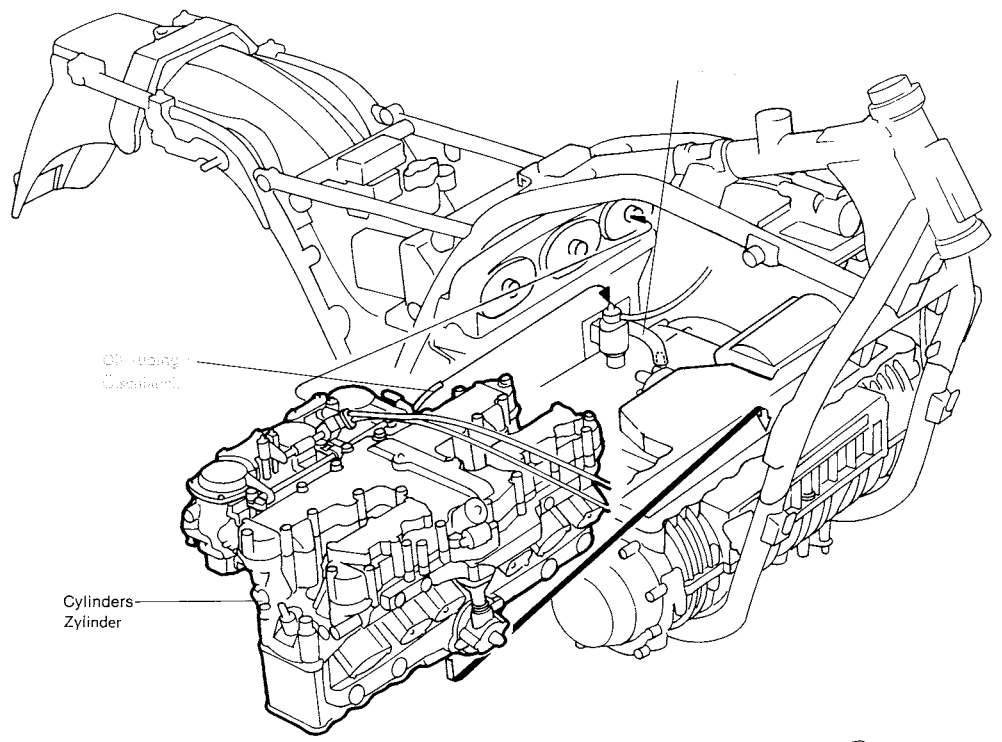
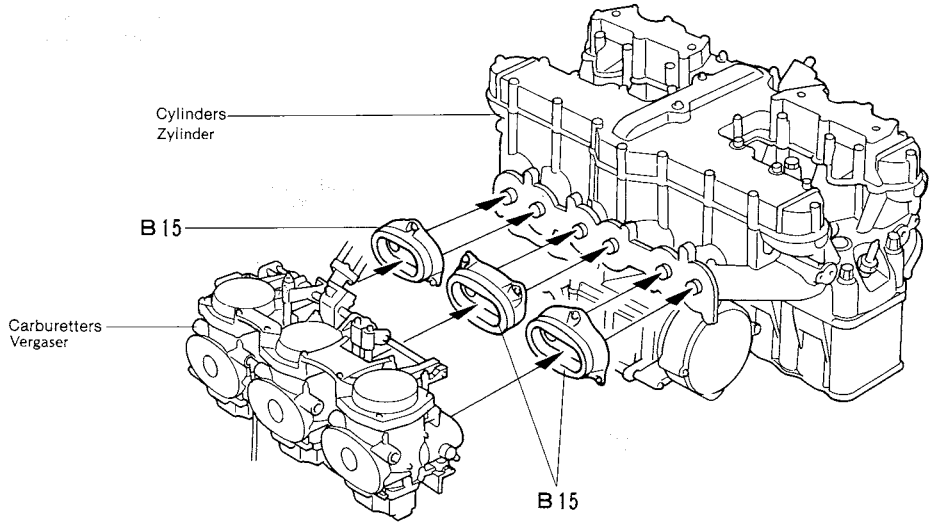
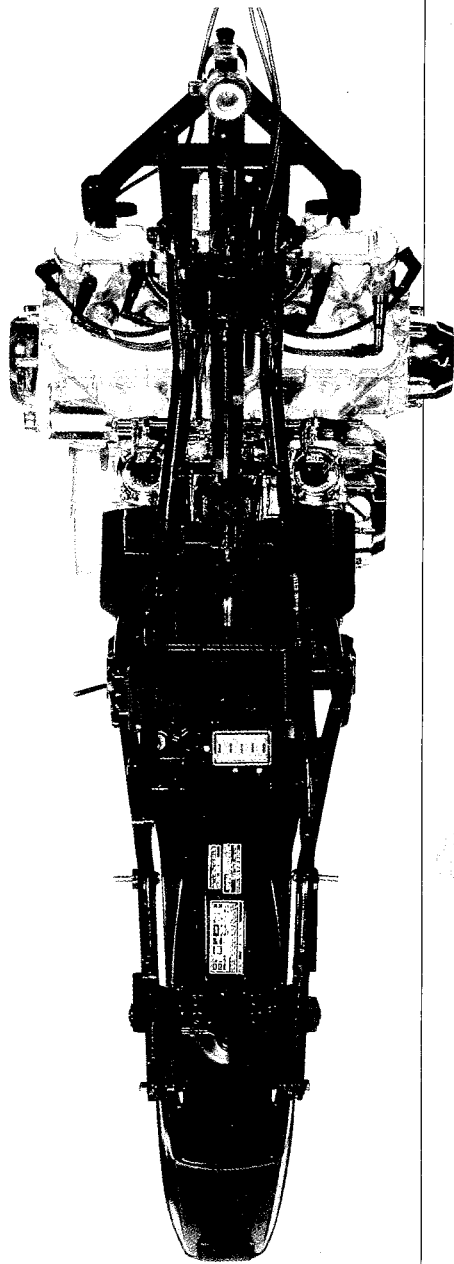

TAMIYA COLOUR CATALOGUE
The latest in cars, boats, tanks and ships. Motorized, radio controlled and museum quality models are all shown in full colour in Tamiya's latest catalogue. At your nearest hobby supply house.

15 «Assembled Rear Wheel»
«Komplette Hinterradmontage»

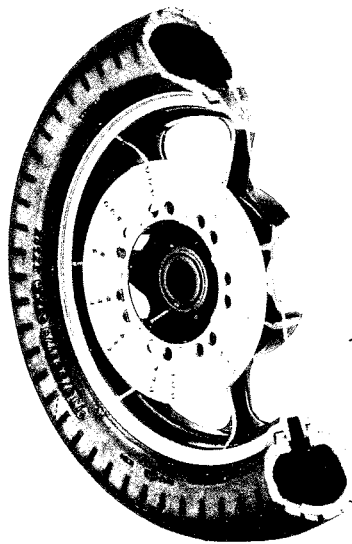

15 «Assembled Rear Wheel»
«Komplette Hinterradmontage»

Cut universal boot as shown below.
Gummimanschette wie gezeigt schneiden.

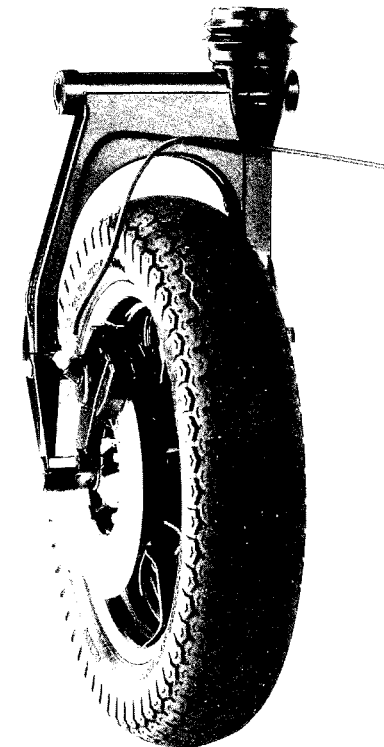
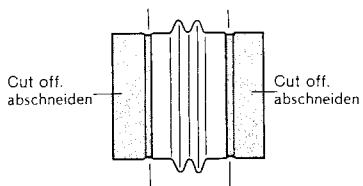

16 «Completed Rear Shock Absorber»
«Hintere Stossdämpfer»

Tighten 2mm×28 screw to H25, and then cement H23 and H24.
2mm×28 Rundkopfschraube in H25 einschrauben.

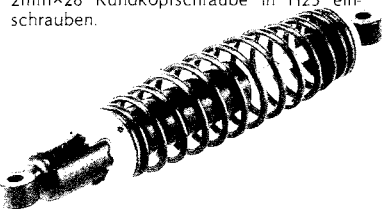

17 «Assembly of Rear Wheel Hub»
«Hinterrad Nabe Montage»

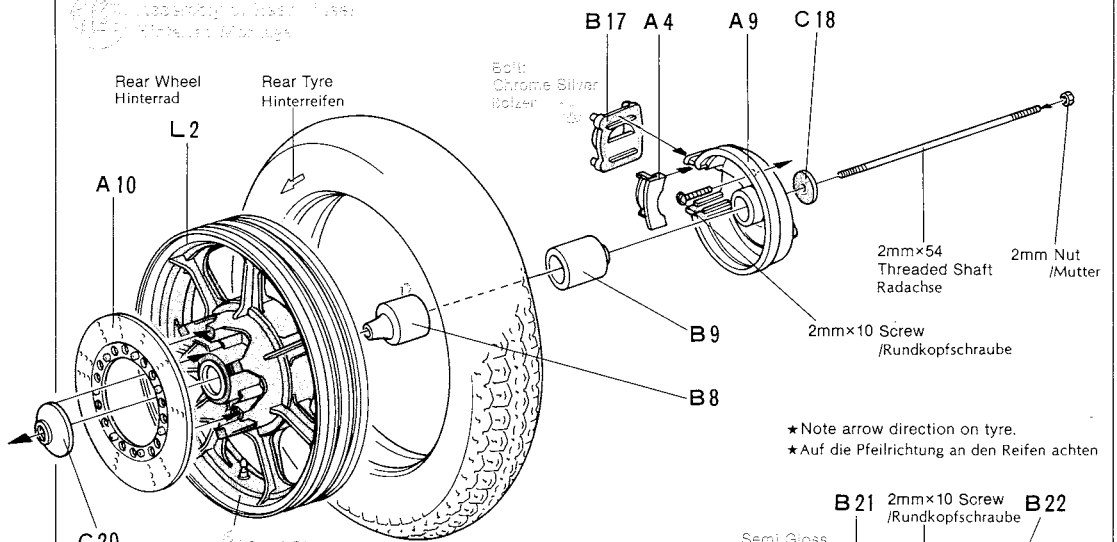

★Note arrow direction on tyre.
★Auf die Pfeilrichtung an den Reifen achten

17 «Rear Wheel and Spring Arm»
«Zusammenbau Hinterrad Gabel und Achse»

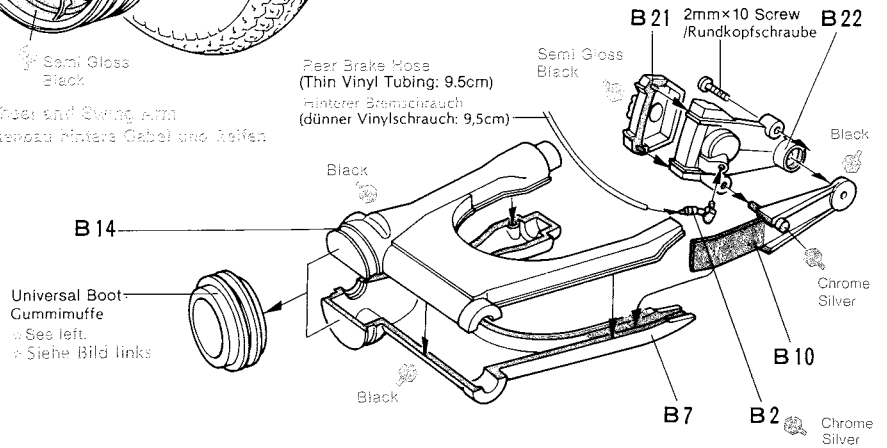

16 «Assembly of Rear Shock Absorber»
«Hintere Stossdämpfer Montage»

(Make 2 sets.)
(2 Satz machen.)

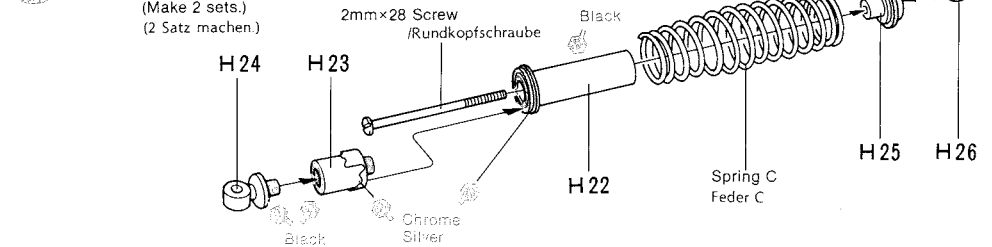

17 «Ignition System and Water Reservoir»
«Zündung und Wasserbehälter»

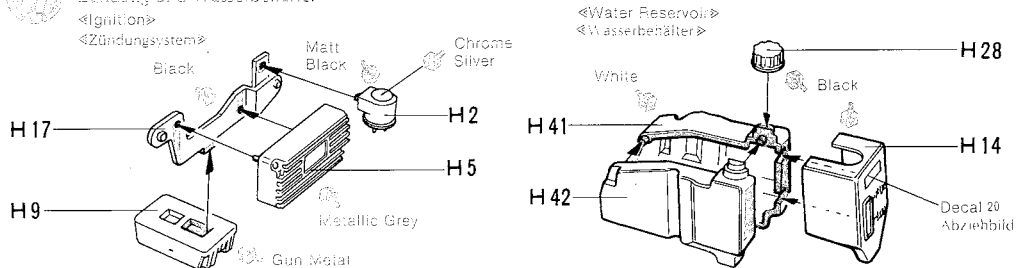

18 <<Attached Rear Wheel>>
<<Eingebautes Hinterrad>>

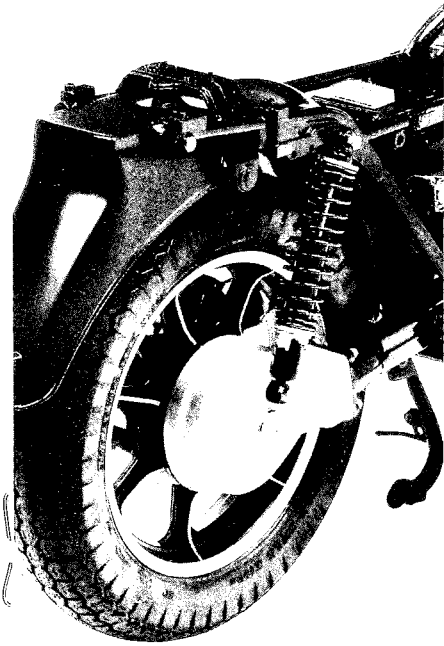

18 Attaching Rear Swing Arm
Einbau der hinteren Rädgabel

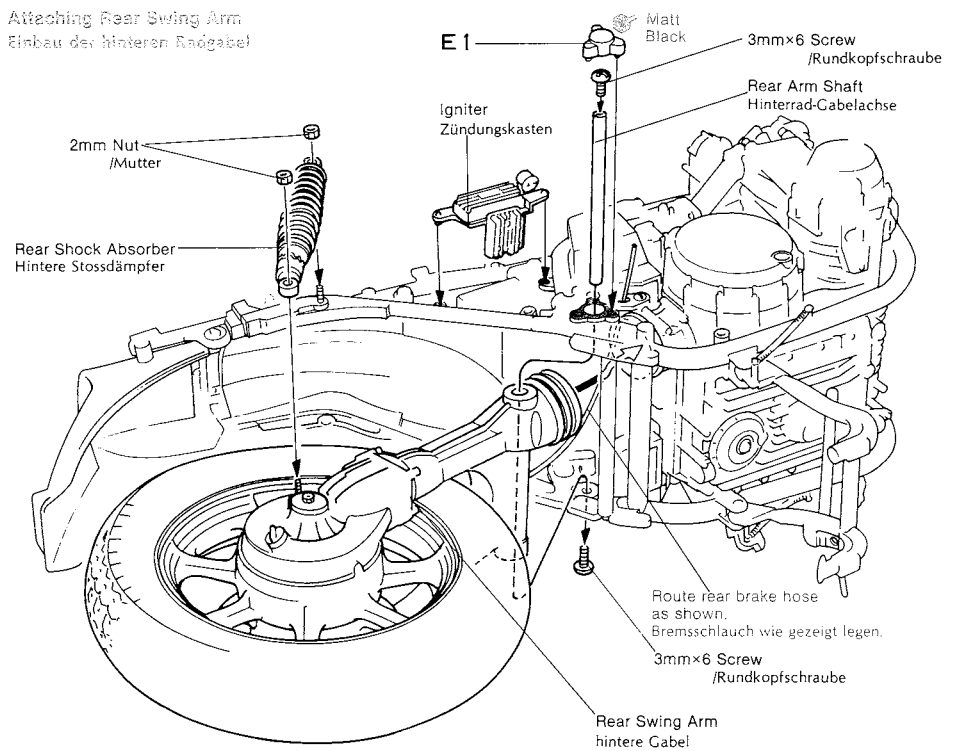

19 <<Assembly of Lock>>
<<Verriegelung>>

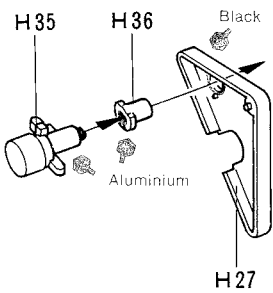

<<Attaching F18>>
<<Einbau F18>>

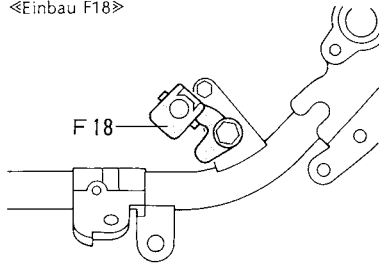

19 Attaching Rear Shock Absorber
Einbau der hintere Stossdämpfer

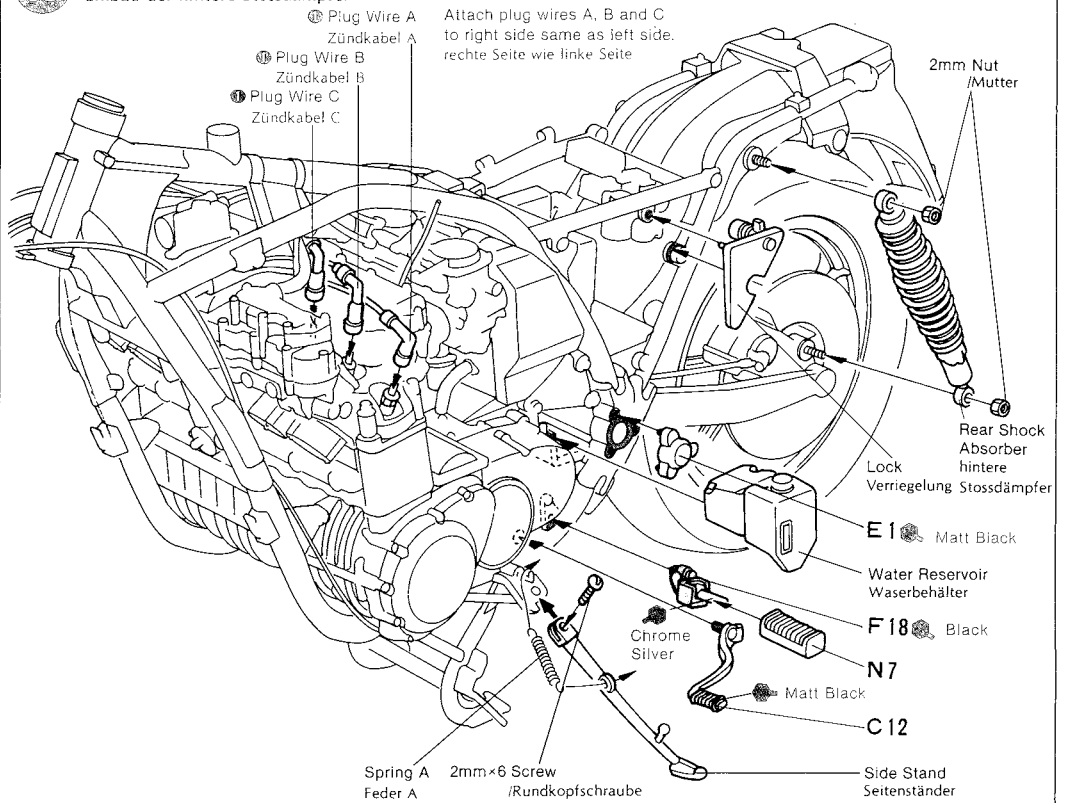

20 Assembly of Exhaust Chamber
Zusammenbau Auspuffgabel

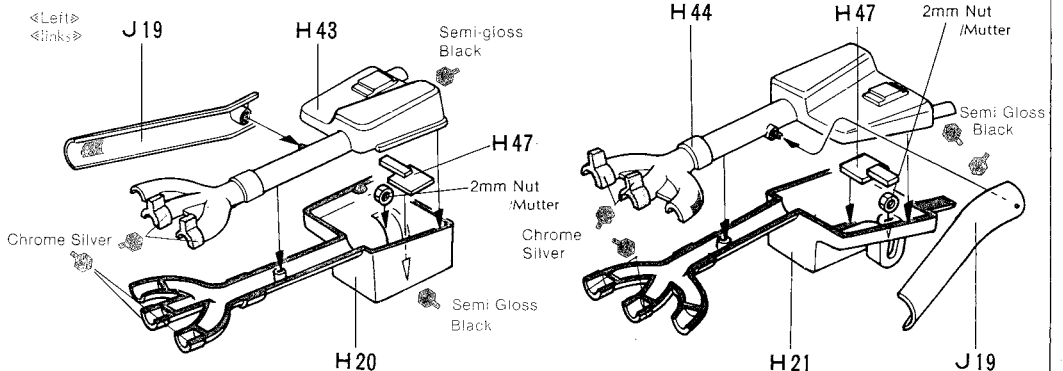

PAINTING

Hold small parts with tweezers to facilitate work.
Kleine Teile hält man mit Pinzette

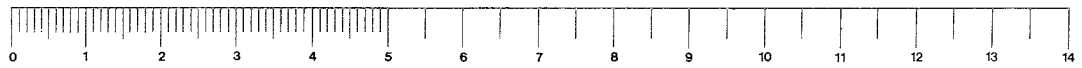
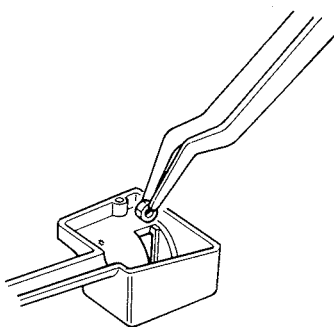

21 <<Attach Exhaust Pipes>>
<<Auspuff Einbau>>

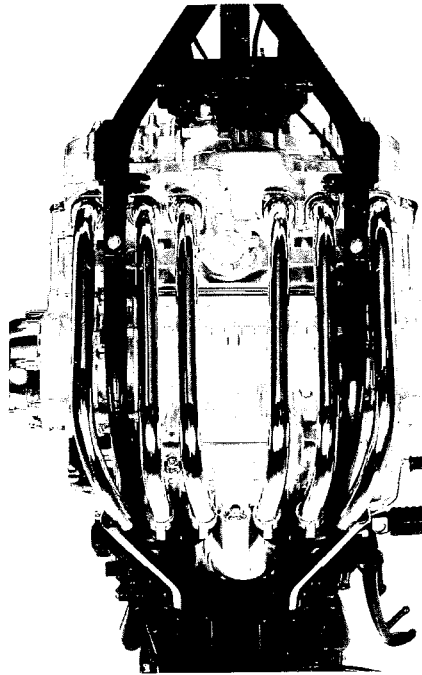

21 Attaching Exhaust Pipes
Auspuff Einbau

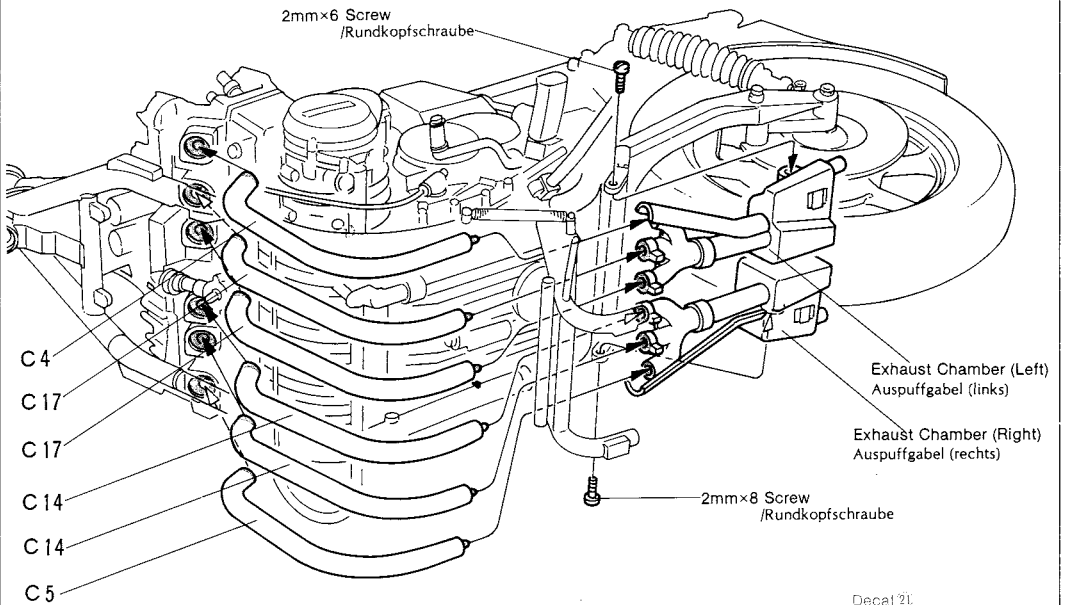

23 <<Assembly of Rear Brake Cylinder>>
<<Bau des Hinterrad-Zylinders>>

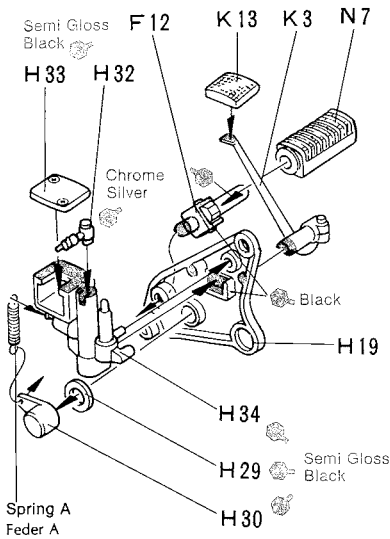

<<Attaching H30>>
<<Einbau H30>>

Movement restricting pin on H10 must be placed between flanges on H19 as shown.
Der Spitze Zapfen von Teil H30 muß (zur Einschränkung der Bewegung) zwischen die Zapfen des Teiles H19. Siehe Bild.

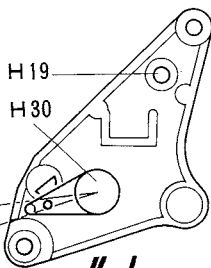

22 Assembly of Radiator
Zusammenbau Kühler

<<Fan>>
<<Ventilator>>

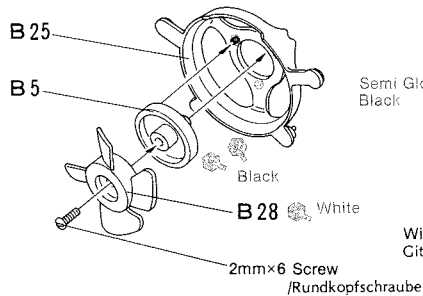

23 Attaching Radiator
Einbau der Kühler

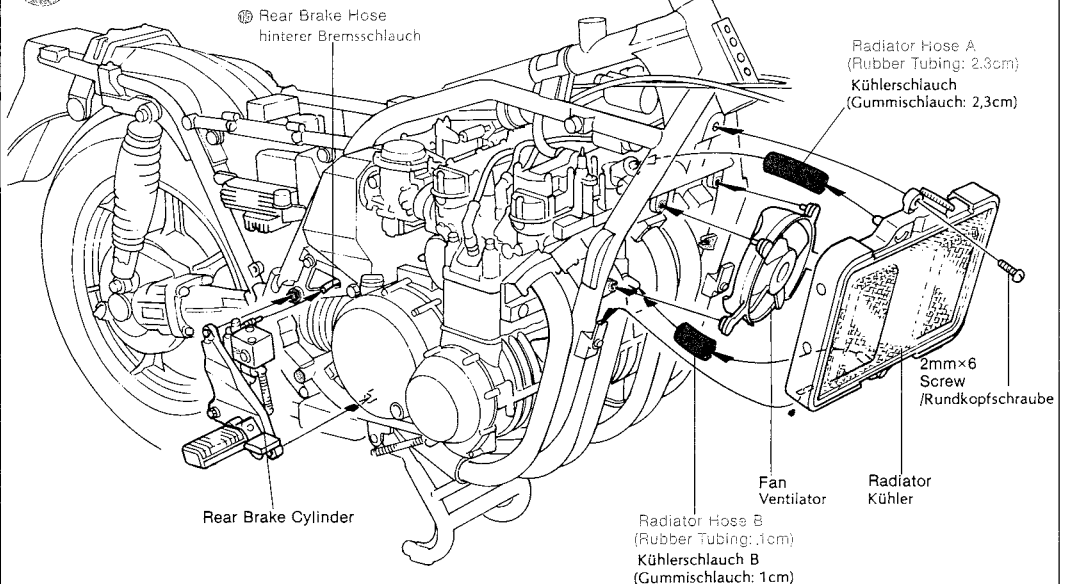

24 Assembly of Headlight
Bau der Lampe und Blinker

<<Front Blinker>>
<<vord. blinklampe>>

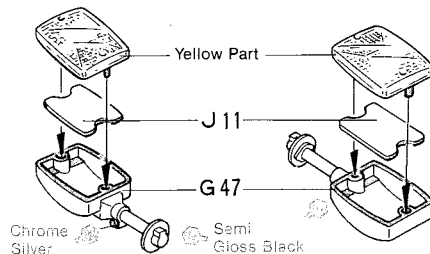

<<Headlight>>
<<Scheinwerfer>>

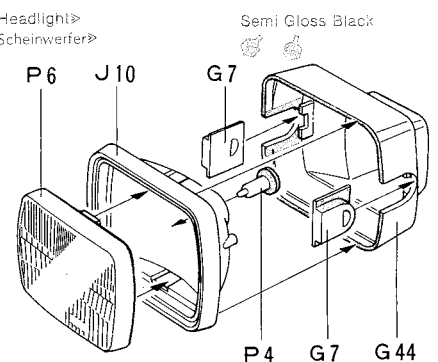

«Front Suspension»
 «Teile der Vordergabel»
 «Applying Decals to Combination Meter»
 «Tacho-Abziehbilder»

Decal 16
 Abziehbild
 Decal 17
 Abziehbild
 Decal 18
 Abziehbild
 Decal 19
 Abziehbild

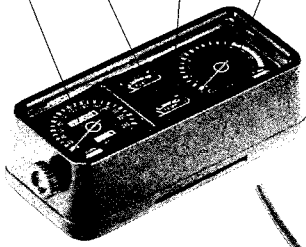

«Applying Decals to Switch Panel»
 «Schalter-Abziehbilder»

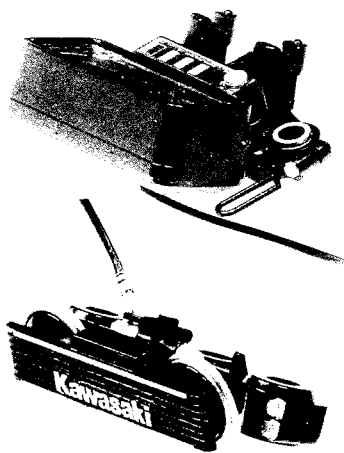
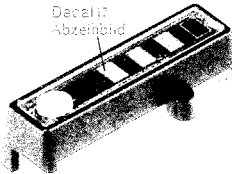

«Painting the Front Forks»
 «Farben der Gabel»

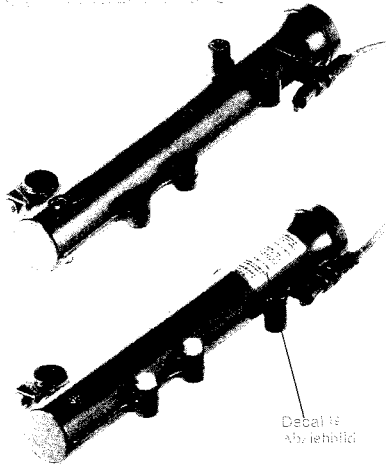

«Painting small parts»
 Paint small parts before removing from sprue and touch up after assembly.

«Kleine Teile bemalen»
 Kleine Teile am Spritzling bemalen. Die Schnittflächen erst nach dem Einbauen bemalen.

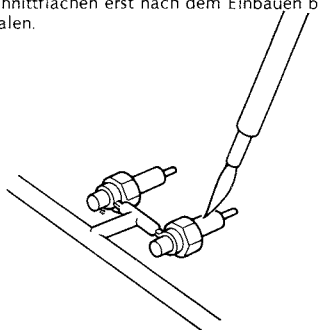

25 Assembly of Front Suspension Parts
 Teile der Vordergabel

«Combination Meter»
 «Tacho-Combination»

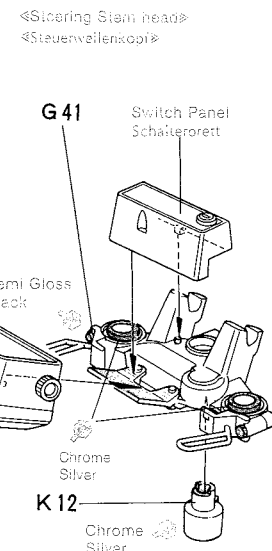
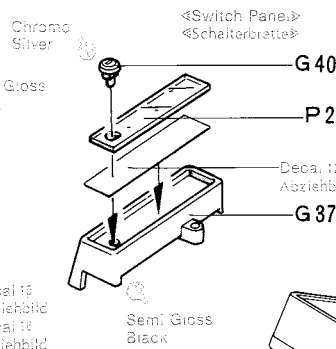
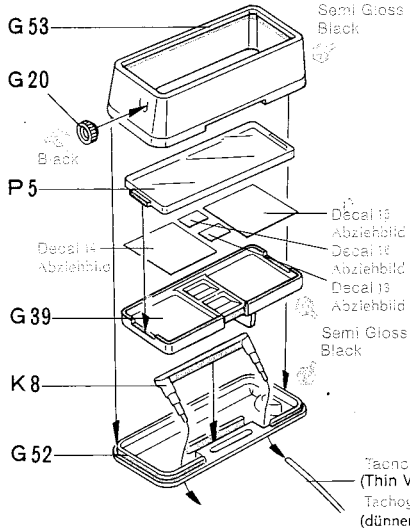

«Steering Stem»
 «Steuervoll»

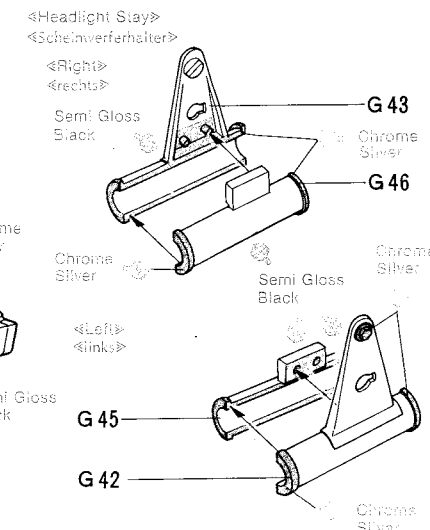
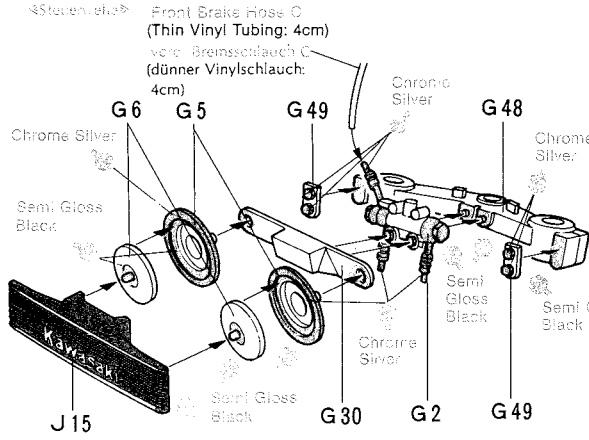

26 Assembly of Front Brake
 Bau des Vorderrads

«Right» «rechts»

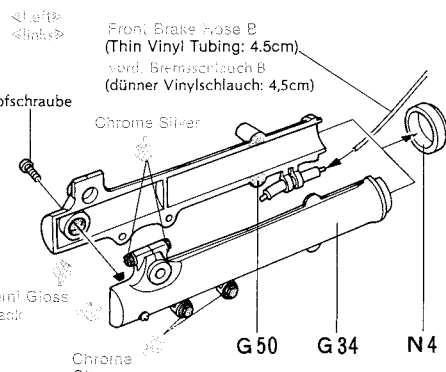
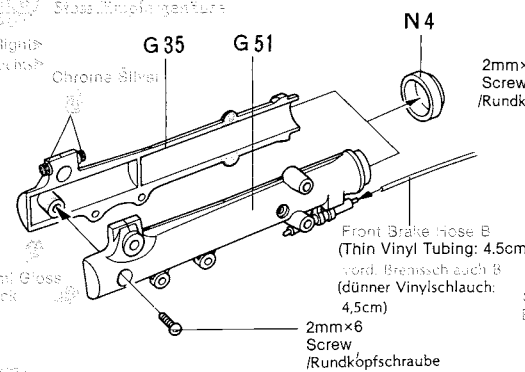

27 Assembly of Front Wheel
 Bau des Vorderrads

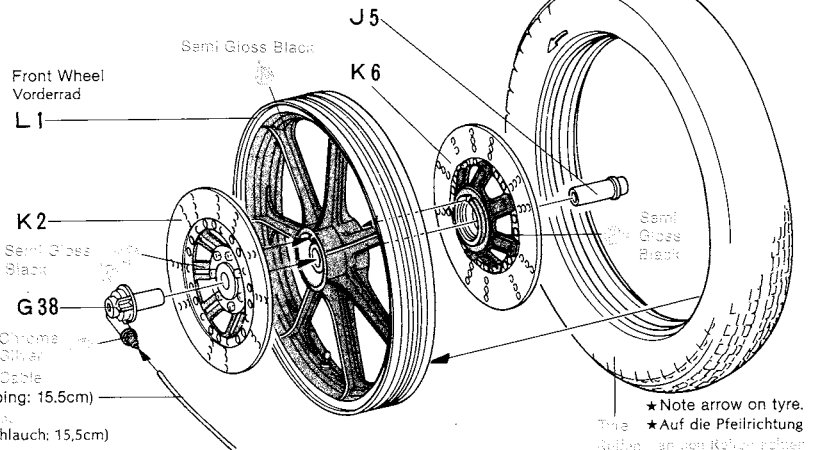

28 <<Assembled Front Brakes>>
<<Scheinbremse>>

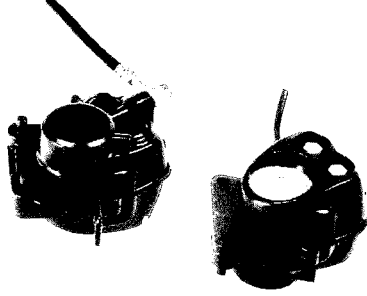

29 <<Applying Decals to Front Fender>>
<<Abziehbilder auf vorderem Schützblech>>

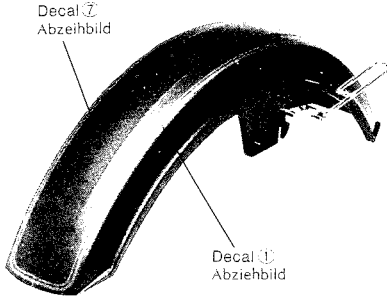

31 <<Front View>>
<<Ansicht von Vorne>>

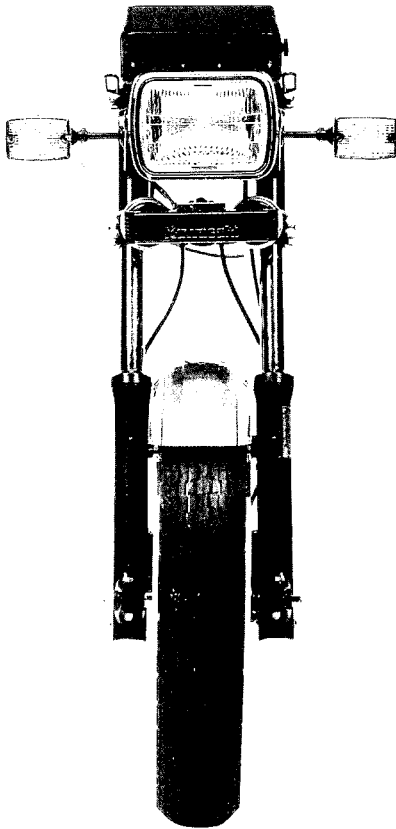

PAINTING

Shave flash at connected parts and then paint with a flat brush.
Klebestellen glatt machen und mit flachem Pinsel bemalen.

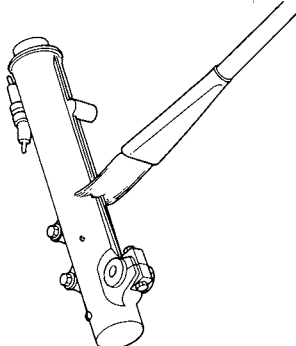

28 Assembly of Front Brakes
Zusammenbau der Scheibenbremse

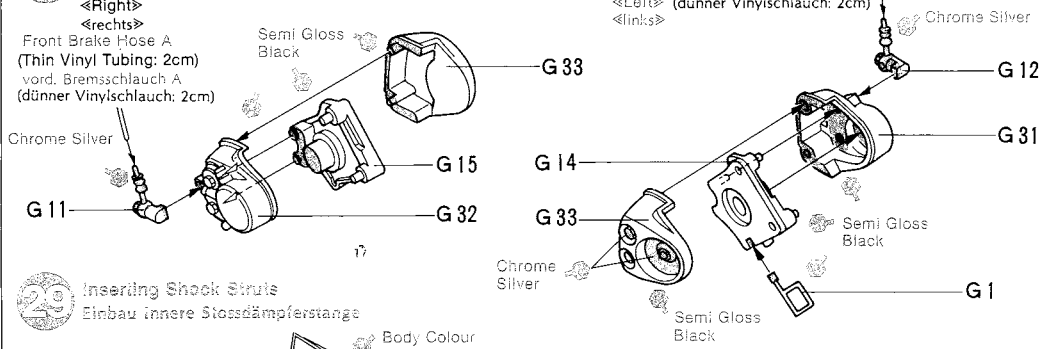

29 Inserting Shock Struts
Einbau innere Stossdämpferstange

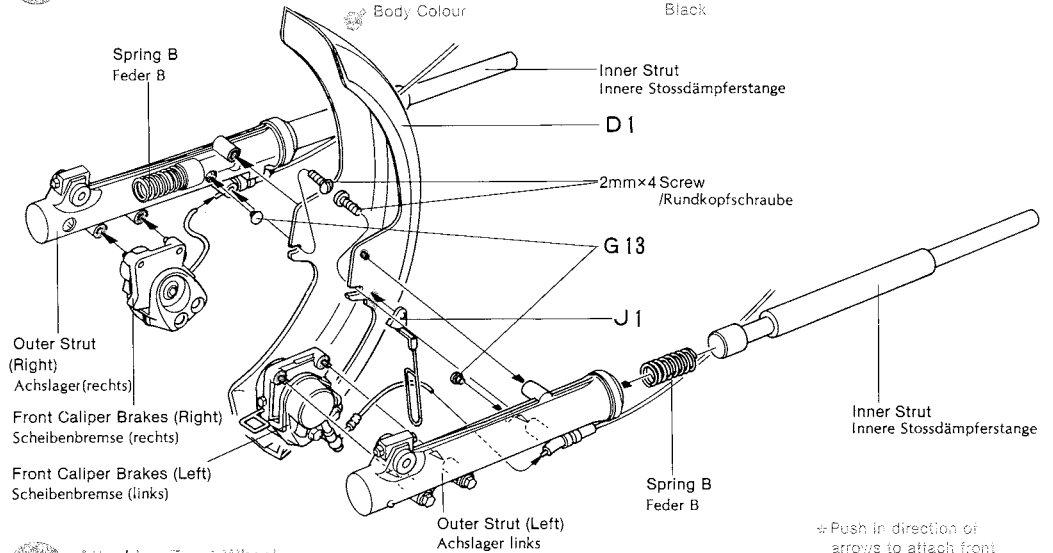

30 Attaching Front Wheel
Einbau des Vorderrades

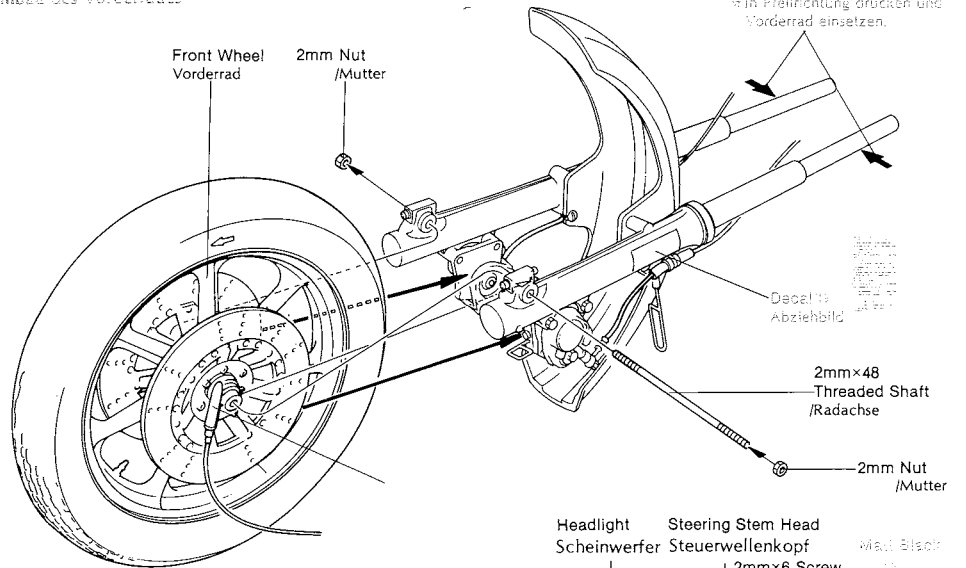

31 Assembly of Front Fork
Bau der Vorderrad-Gabel

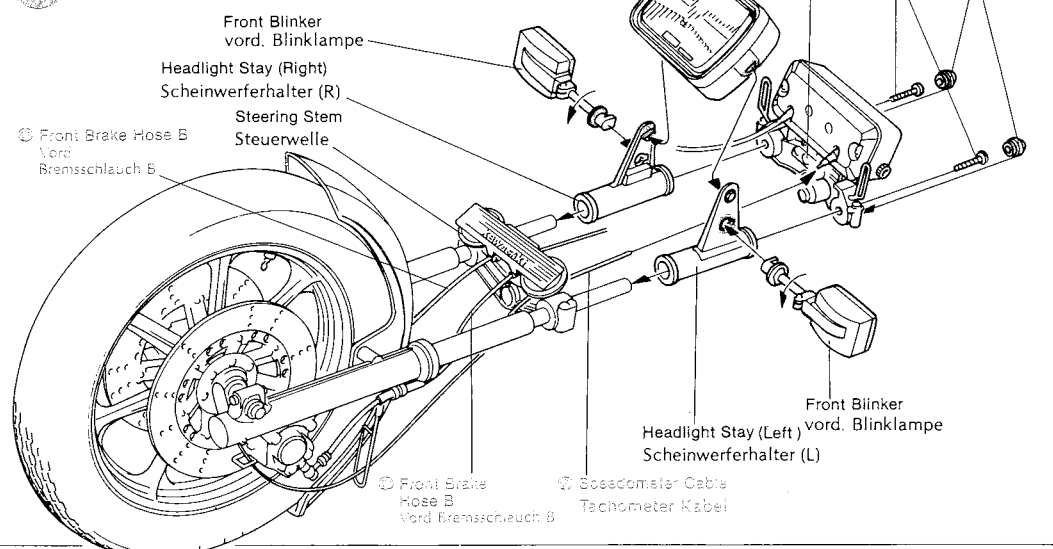

32 <<Front Fork>>
<<Vorderrad-Gabel>>

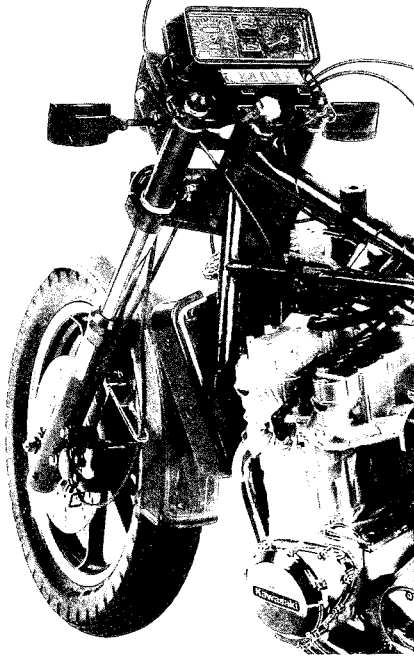

32 Attaching Front Fork
Einbau Vorderrad-Gabel!

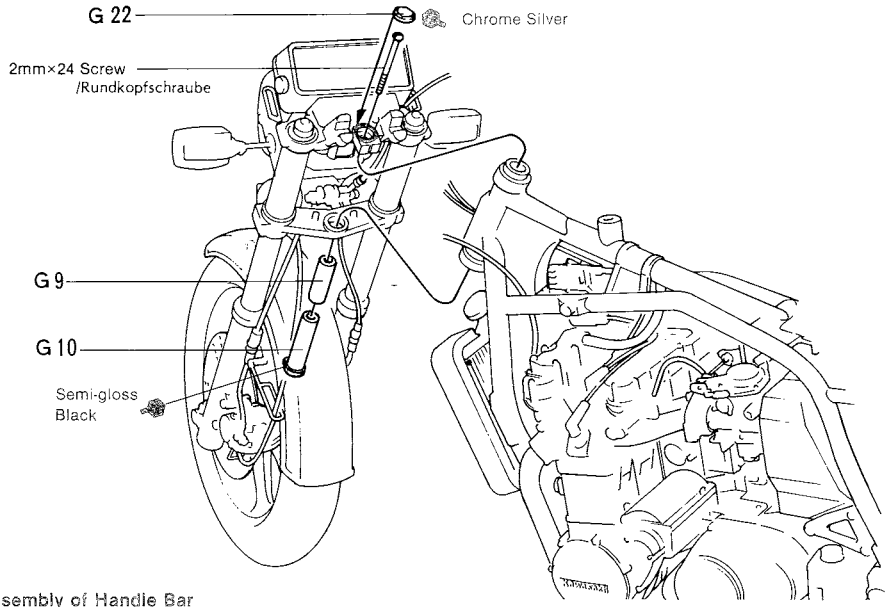

33 <<Ends of Handle Bar>>
<<Lenkstangriffe>>

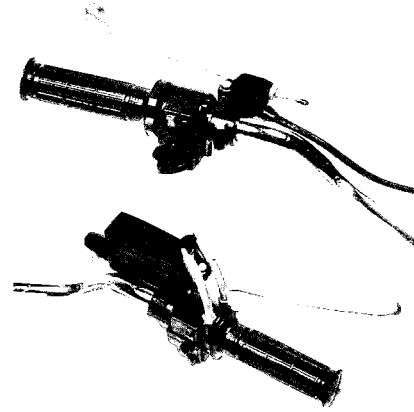

33 Assembly of Handle Bar
Bau der Lenkstange

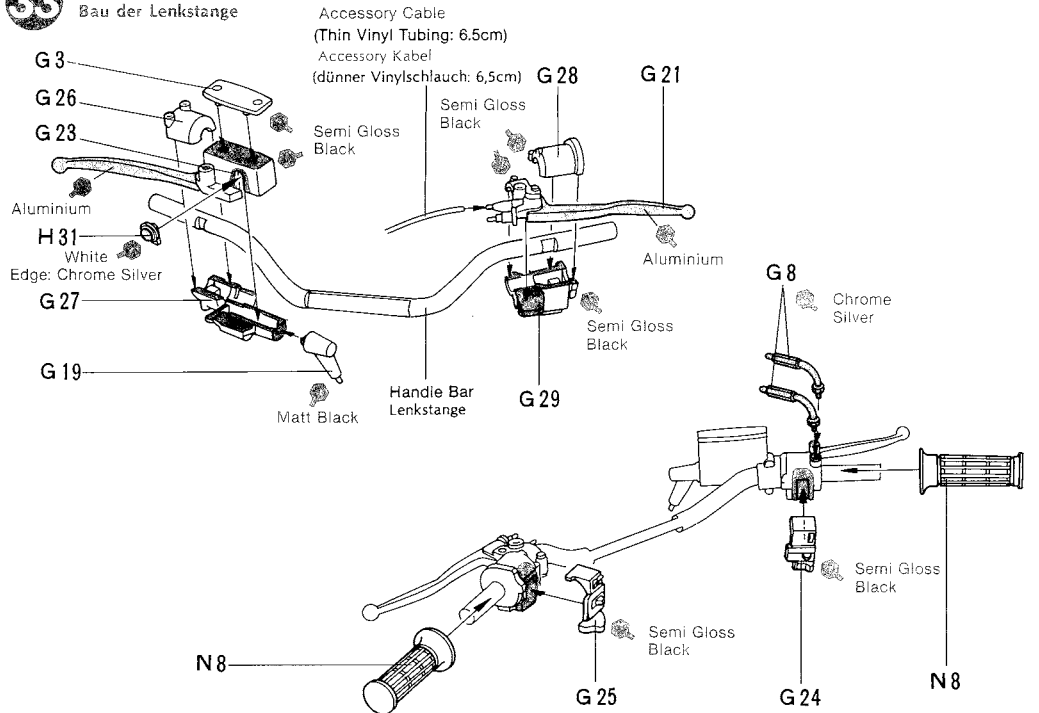

34 <<Handle Bar>>
<<Lenkstange>>



34 Attaching Handle Bar
Einbau Lenkstange

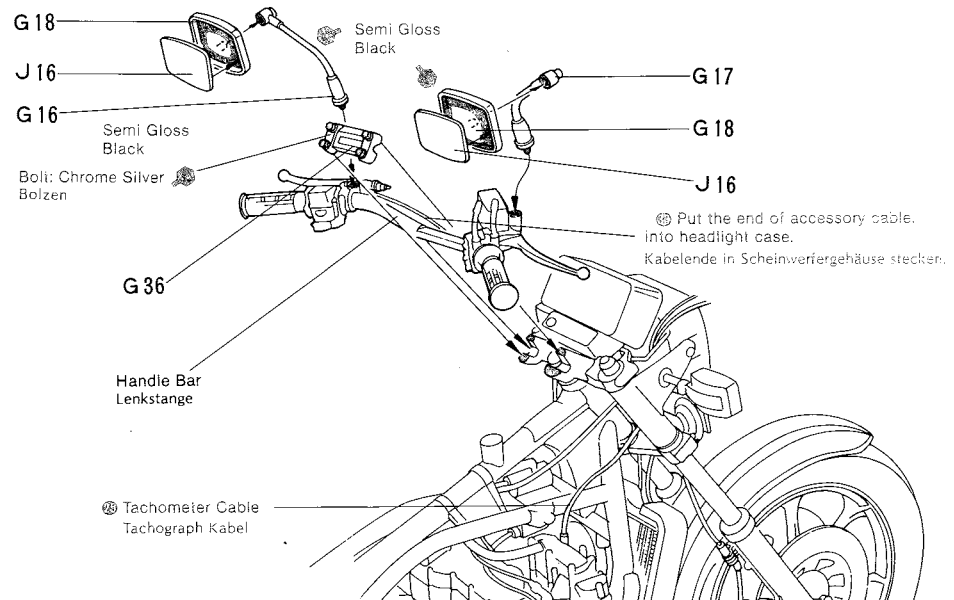

BUILT A COLLECTION OF TAMIYA PRECISION MOTORCYCLE MODELS

1/6 YAMAHA XS1100 LG MIDNIGHT SPECIAL



«Taillight»
«Rückleuchte»

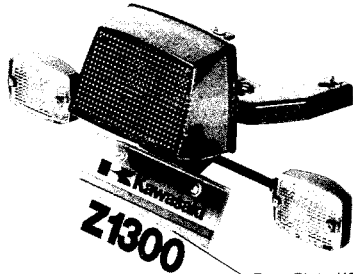

Rear Plate K9
hinteres Schild K9
Decal 27
Abziehbild

Rear Plate K10
hinteres Schild K10
Decal 27 or 28
Abziehbild 27 oder 28

**XVJ
44T**

«Applying Decals to Tank»
«Abziehbilder auf Benzintank»

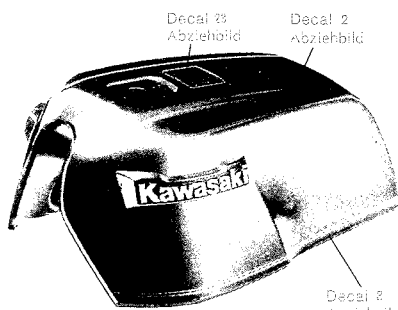

Decal 23
Abziehbild

Decal 2
Abziehbild

Decal 8
Abziehbild

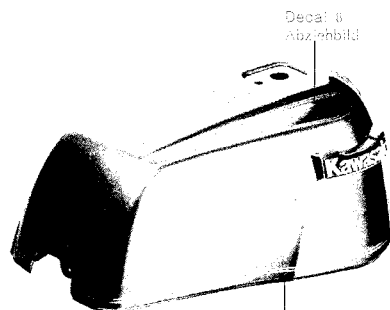

Decal 6
Abziehbild

Decal 9
Abziehbild

«Applying Decals to Right Side Cover»
«Abziehbilder auf rechten Decke»

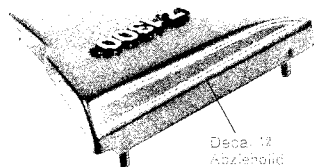

Decal 12
Abziehbild

PAINTING

«Repair of worn-off Plating»
«Chromteile»

Apply silver paint with a very fine pointed brush to make good any damaged chrome work.
Schadhafte Stellen der Chromschicht mit spitzem Pinsel und Silber Farbe ausbessern.

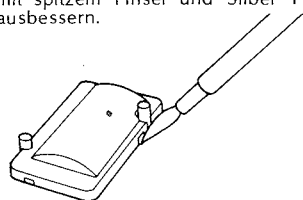

Assembly of Taillight
Zusammenbau Rückleuchte

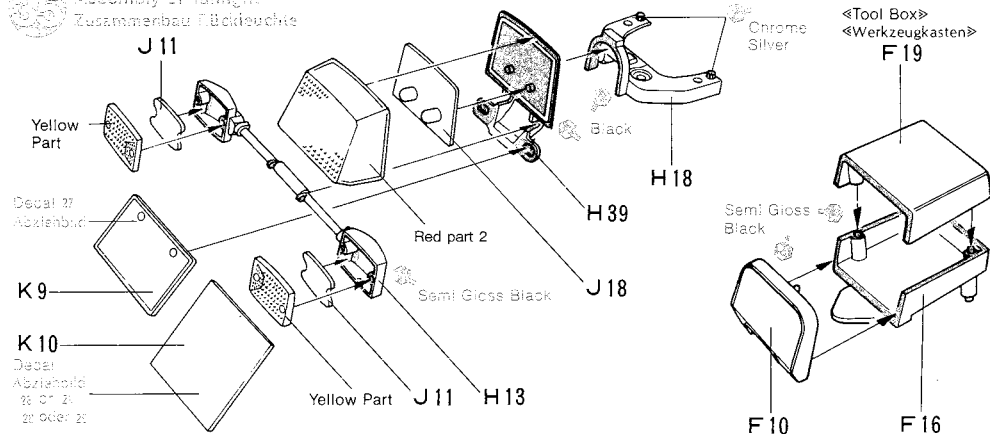

Assembly of Mufflers
Zusammenbau Auspuff

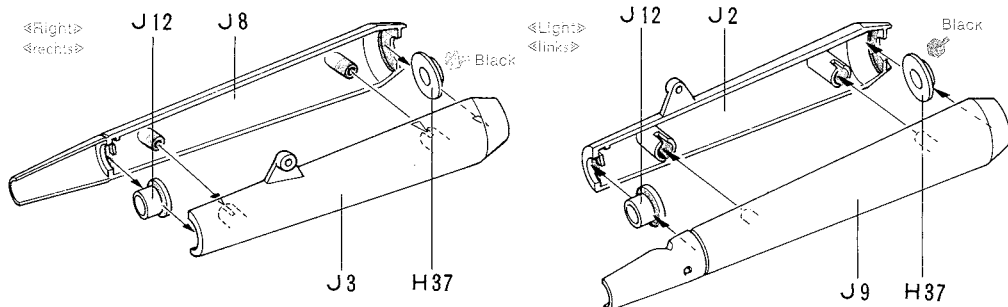

Assembly of Fuel Tank and Saddle
Zusammenbau Tank und Sattel

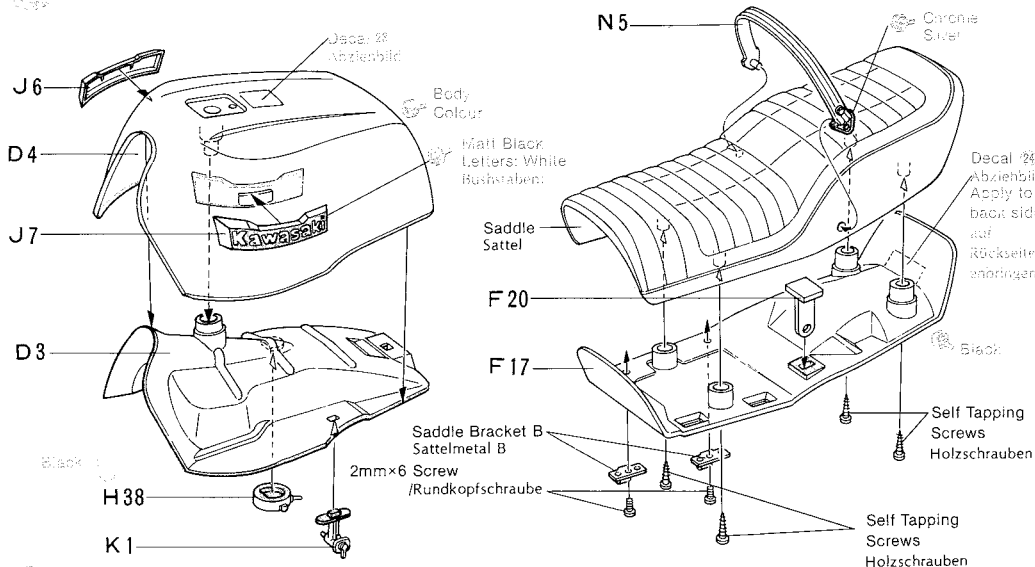

Attaching Right Muffler
Einbau rechten Auspuff

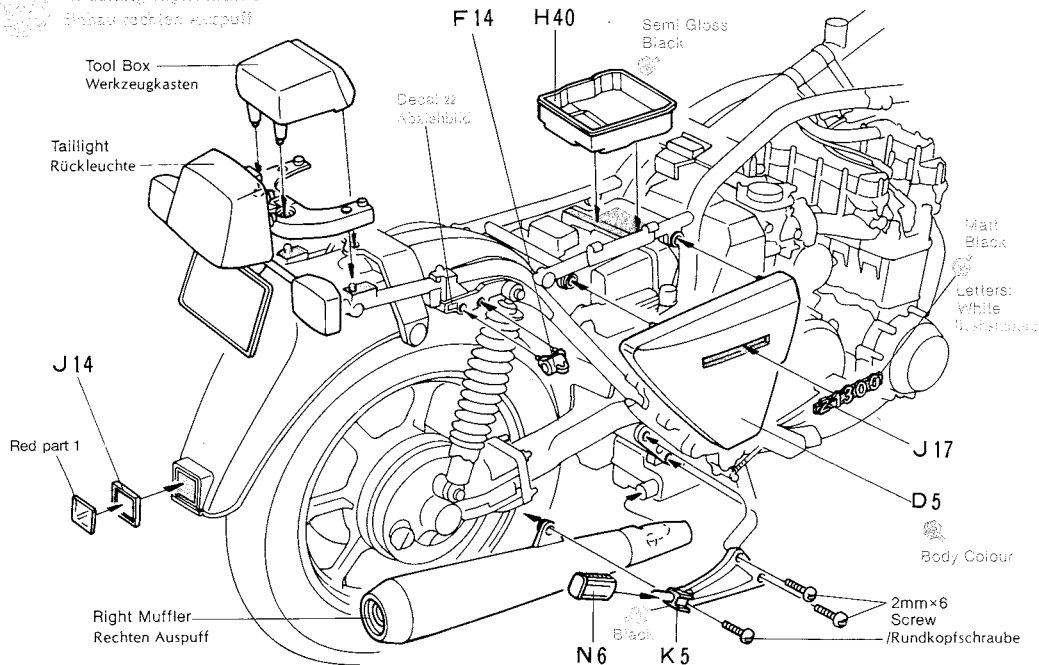

39 «Assembly of Battery»
«Zusammenbau der Batterie»

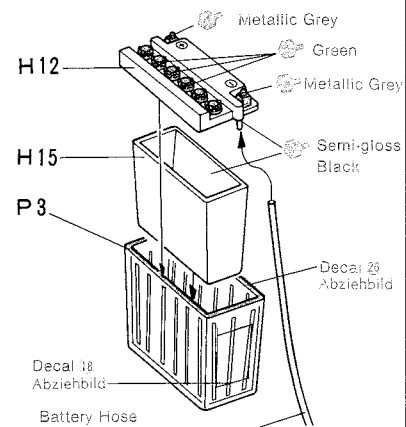

Battery Hose (Thin Vinyl Tubing: 6cm)
Batterieschlauch (dünnere Vinylschlauch: 6cm)

«Applying Decals to Saddle Cowl»
«Abziehbilder auf Sattelverkleidung»

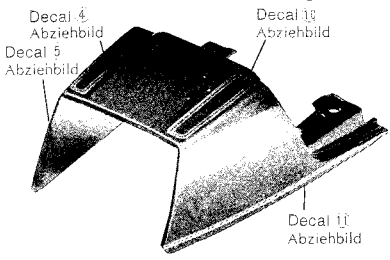

«Applying Decals to Left Side Cover»
«Abziehbilder auf linken Deckel»

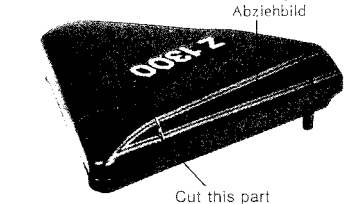

Cut this part after decal is completely dry.
Nach Trocknen des Bildes, dieses Teil abschneiden

«Opening Saddle»
«Öffnen des Sattels»

You can open saddle by loosening 2mm×8 Round Head Screw.
Sattel öffnen: Schraube lockern

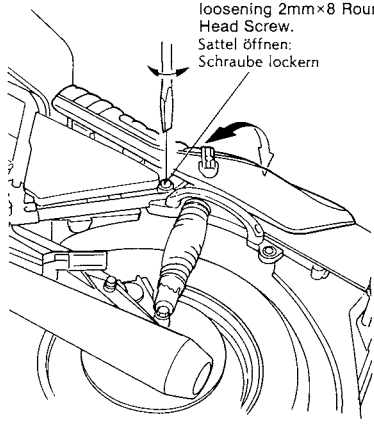

39 Attaching Left Muffler
Einbau linker Auspuff

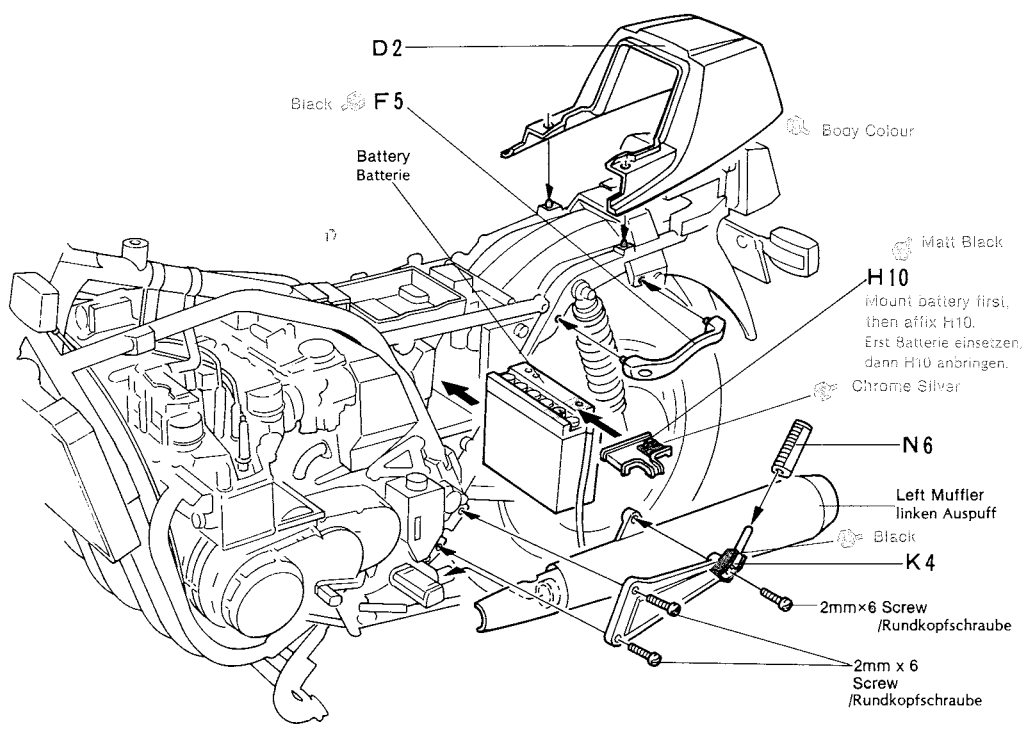

40 Final Assembly
Endmontage

«Left Side Cover»
«Linker Seitendeckel»

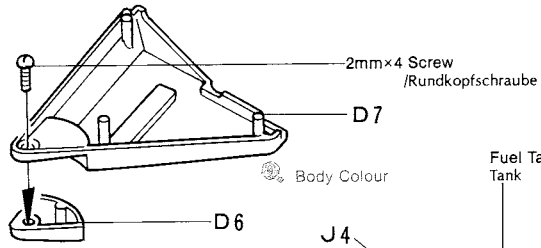

*Saddle is set by tightening 2mm×8 screw as shown.
*Sattel mit Schraube befestigen.

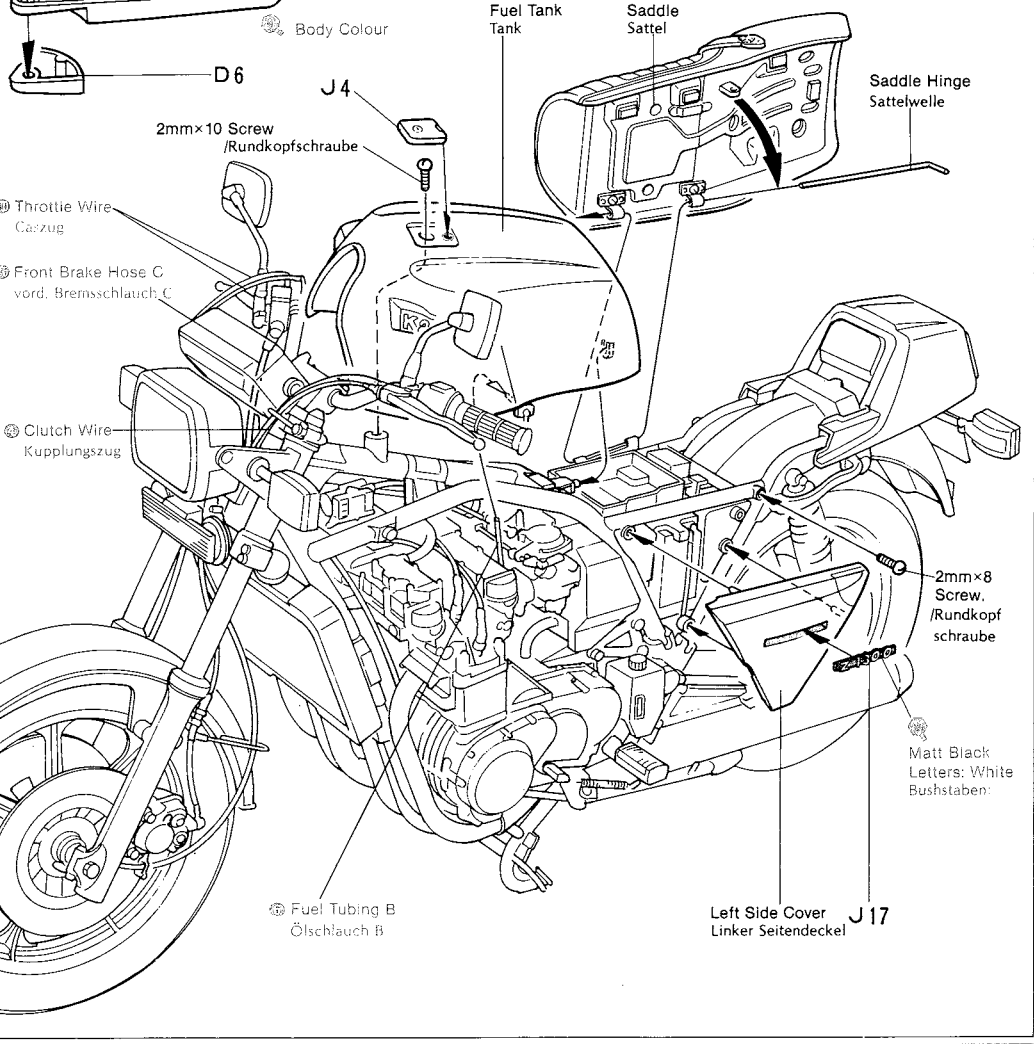

Left Side Cover J17
Linker Seitendeckel

PAINTING & APPLYING DECALS

«Painting of Kawasaki Z1300»

The Z1300 was originally released in two colours, "Luminous Starlight Blue" and "Luminous Ruby Red." Later, Black and Light Green were added as standard colours. Thin gold striping is added as accent for the overall scheme as shown in the drawings, on the fuel tank; front fender; and fairing at rear of saddle. Entire rear mud guard/fender is in semi gloss black. Some parts are painted prior to assembly as called out in the instructions, as well as application of some of the decals. Some plastic paints will affect the decals, so test on scrap decal prior to over-painting finished model with clear paint.

«Bemalung der Kawasaki Z1300»

Die Z1300 wurde erst in zwei Farben vorgestellt: Leucht- Starlight Blue und Leucht Ruby Red. Später wurden noch Schwarz und Hellgrün als Standard-Farben dazugenommen. Ein dünner Goldstreifen ist als Akzent über die ganze Maschine gezogen, siehe Zeichnungen, auf dem Tank, vorderes Schutzblech, und über den Sattel. Der ganze hintere Schmutzfänger ist in halbgläzendem Schwarz. Einige Teile sind wie in der Anleitung angegeben bemalt. Bitte beachten, dass Farben die Abziehbilder beschädigen können. Wollen Sie das ganze Modell mit Klarlack besprühen, erst prüfen, ob Lack keinen Schaden verursacht.

«Painting Implements»

Have the following ready to hand: a flat brush for painting large areas, slender and pointed brushes for painting small parts, trays for mixing paints, sprays etc. After painting, remove paint from the brushes with thinner and wash them in water. Lacquer thinner is cheap and good for washing the brushes, but it must be handled with care because it melts plastic.

«Zubehör für die Bemalung»

Flacher Pinsel für grosse flächen, dünner und spitzer Pinsel für kleine Teile. Nach Malen den Pinsel mit Verdünner reinigen. Verdünner aber nicht mit Plastik in Verbindung bringen, da sonst Plastik schmilzt.

«Before painting»

Remove all dust dirt and adhesive smears before attempting any painting. Remember painting does not generally hide bad workmanship. As previously mentioned remove excessive cement or joints with a file, sharp knife or very fine emery cloth. Most parts are best painted after assembly, but some inaccessible parts may be painted before removing from the sprue.

«Vor dem Malen»

Soll man Staub und Leimreste entfernen. Auch eine gute Bemalung verdeckt nicht schlechte Bauarbeit. Unebenheiten mit Feile oder Klinge entfernen. Viele Teile lassen sich erst nach dem Zusammenbau bemalen, jedoch die kleinen Teile bemalt man am besten am Spritzling.

«Colours Required»

«Bemalung benötigt»

Metallic Red
Black

White
Green
Chrome Silver
Matt Black
Aluminium

«Spray Painting Hints»

Firstly always spray indoors in windless and dust-free conditions. Spread newspaper under your work. Mix the paint well by shaking the can for three minutes and then test spray against some cardboard from about 20 cm, checking that the paint is properly mixed. When spraying the body, hold the can about 20 cm from the plastic, moving the can quickly always in the same direction and ensure every application. A good tip is to imagine you are spraying a large surface, i.e. the surrounding newspaper, you will then probably achieve a more even finish.

«Bemalung mit Sprayfarben»

Nur in Zug- und staubfreien Räumen spritzen. Teile auf ausgebreitete Zeitung stellen. Spraydose gut durchschütteln (3 Min) und durch

Spritzen auf Karton prüfen, ob Farben gut gemischt ist. (20 cm Abstand). Das Modell in gleicher Richtung grossflächig besprühen. Keine Sprayfarben auf Nitrobasis sondern nur Sprayfarben für Polystyrol Plastik verwenden.

«Decal Application»

① Remove all dust, dirt and adhesive smears with a wet cloth before applying any decals.

② The decal to be applied should be removed beforehand from the decal sheet. Cut off translucent films along coloured parts.

③ Dip the decal in tepid water for about 10 seconds and then remove it onto a clean cloth. Be careful of over immersion to avoid loss of decal's adhesive.

④ Hold the backing sheet edge and slide the decal onto the model.

⑤ Wet the decal with a little water on your finger so that it can be moved more easily into position.

⑥ Press the decal down gently with a clean soft cloth to remove air bubbles and until all excess water has been fully absorbed. When a

decal has to be applied to a surface which is uneven or curved, press the decal down with a hot towel so that the decal will fit the contours perfectly. Cut off the excess transparent portion around each decal. The decal must then not be touched until dry.

«Abziehbilder-Decals»

① Staub, Schmutz und Klebstoffreste mit nassem Tuch entfernen.

② Decals erst ausschneiden entlang den Linien.

③ Decals in Wasser legen, dann nach 10 Sekunden auf z.B. Handtuch legen und etwas abtrocknen lassen.

④ Decal an der Unterlage halten und Bild auf das Modell schieben.

⑤ Mit etwas Wasser auf dem Finger lässt sich das Decal noch etwas verschieben.

⑥ Decal mit etwas Stoff gut andrücken um die Luftblasen zu entfernen und das Wasser abzutrocknen. An unebenen Stellen kann man mit heissen Tuch das Decal besser andrücken. Transparente Überreste am Decal abschneiden. Decal nicht mehr berühren, bis getrocknet ist.

«Painting and Marking of Kawasaki Z1300»

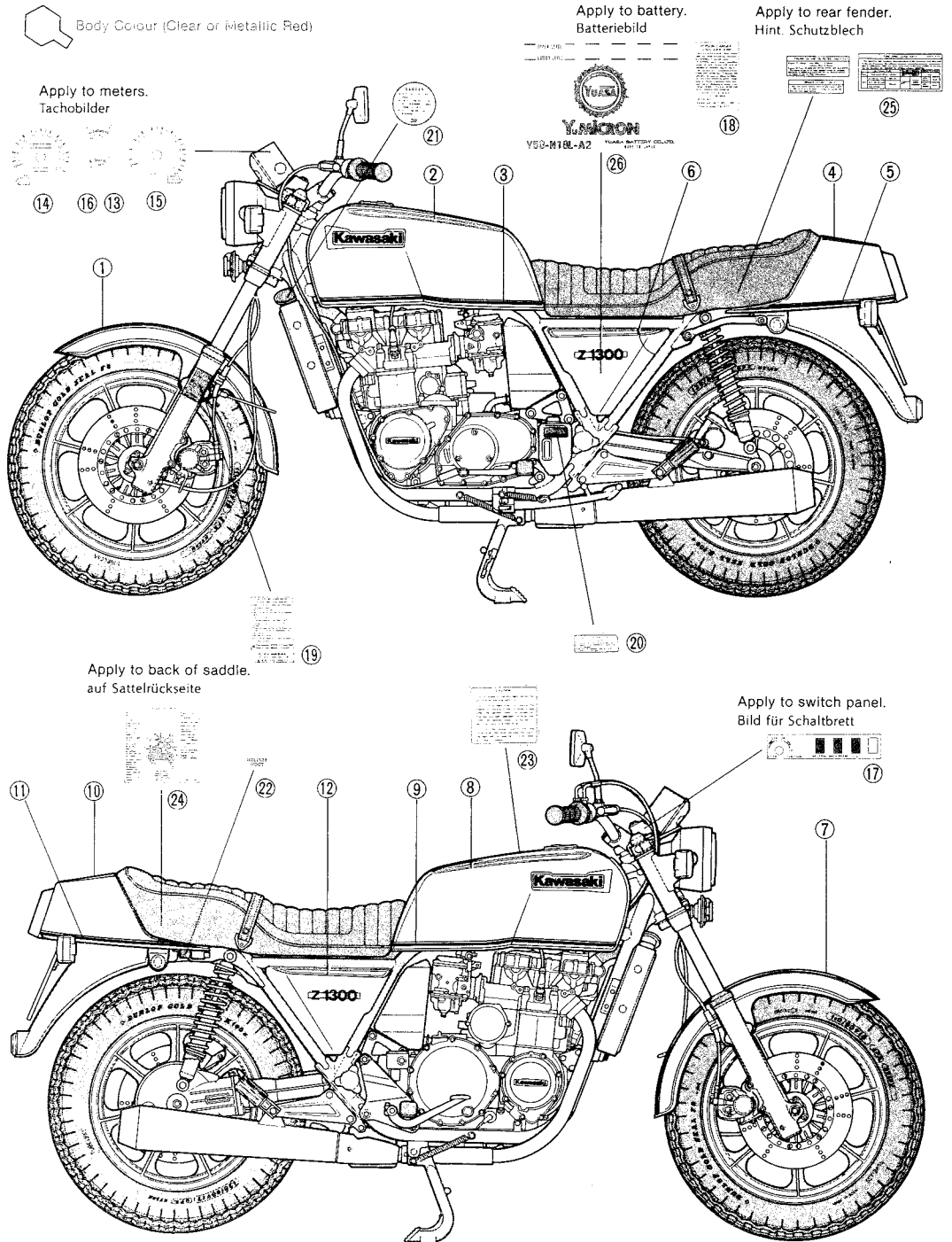

«Bemalung und Markierung der Kawasaki Z1300»





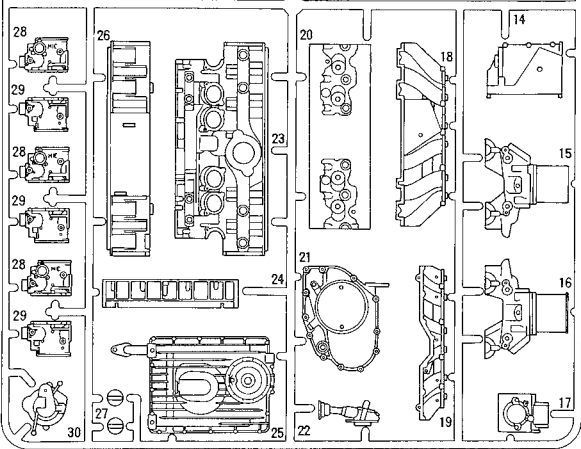
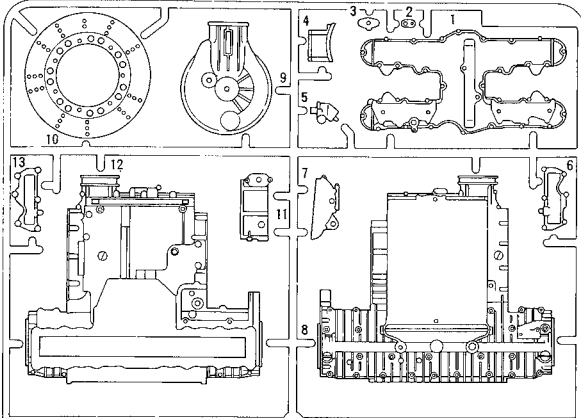

PARTS

A Parts  Matt Plated  Matt Black

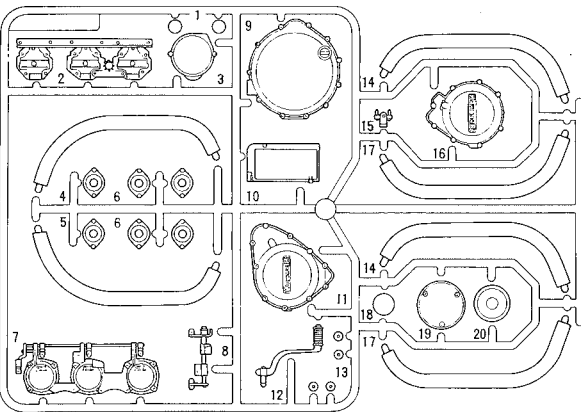





C Parts  Plated  Matt Black

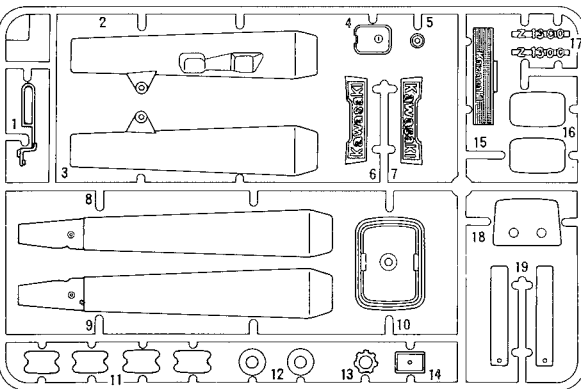

J Parts  Plated  Semi Gloss Black  White



B Parts  Black  Semi Gloss Black  Chrome Silver  White  Matt Black

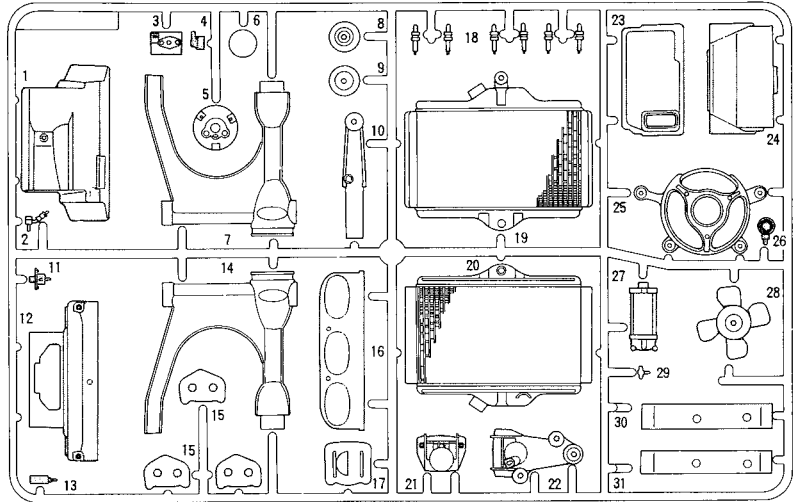

E Parts  Semi Gloss Black  Matt Black  Chrome Silver  Aluminium

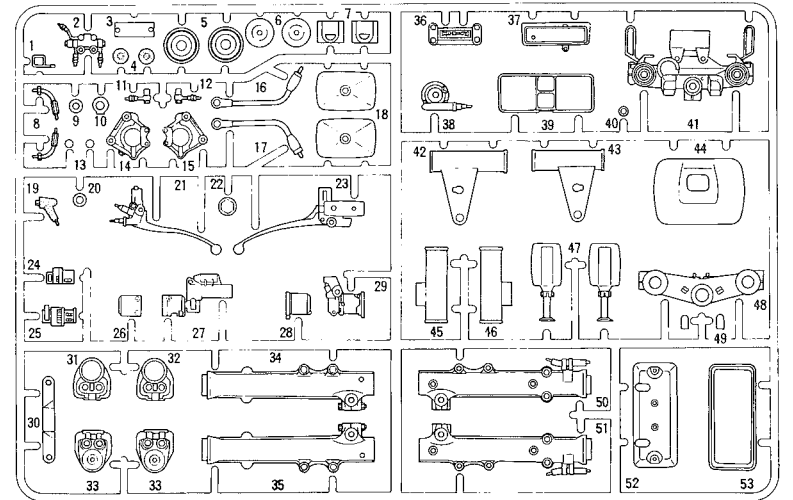

H Parts  Black  Semi Gloss Black  Matt Black  Chrome Silver  White

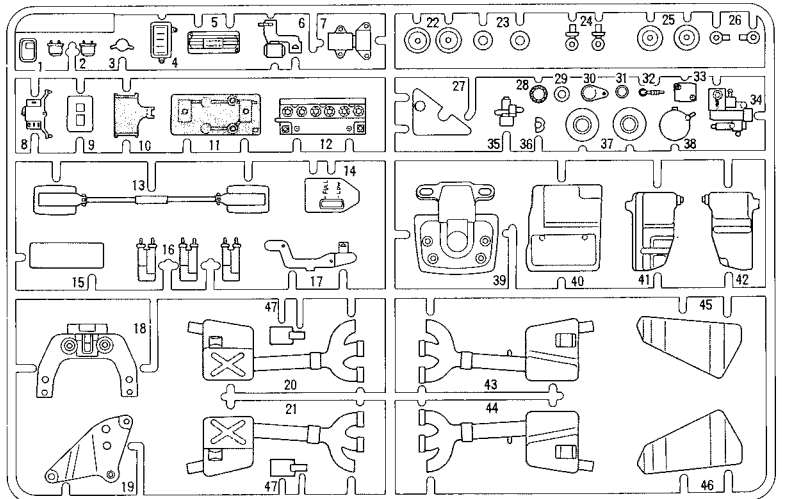

N Parts  Chrome Silver

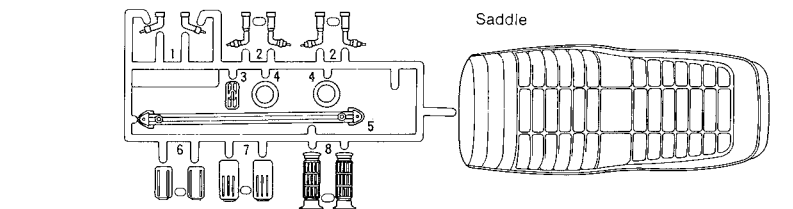

PARTS

F Parts Black Semi Gloss Black Chrome Silver

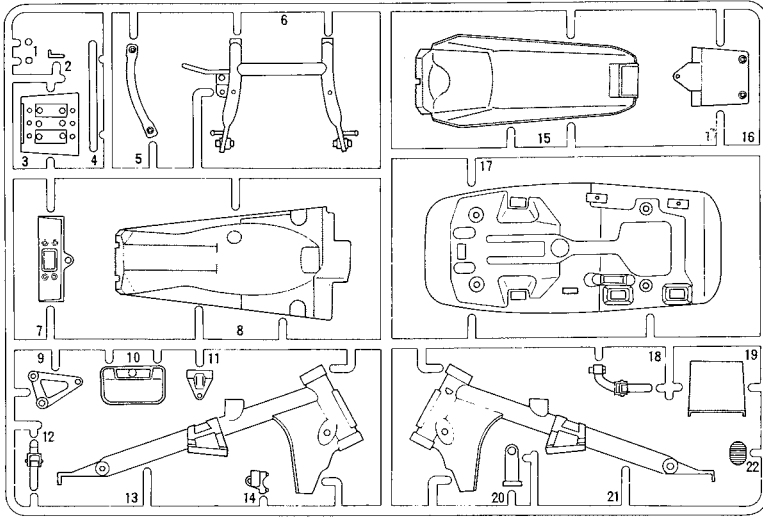

E Parts Black Chrome Silver Matt Black

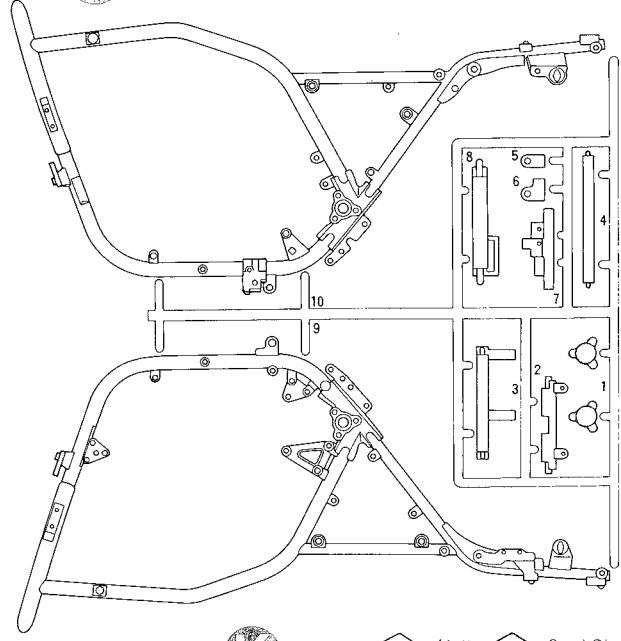

D Parts Body Colour

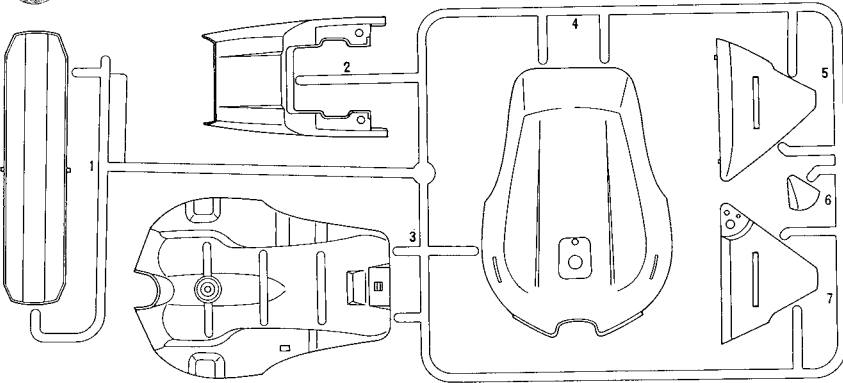

K Parts Matt Plated Semi Gloss Black

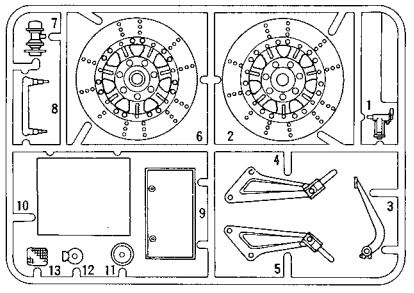

L Parts Matt Plated Semi Gloss Black

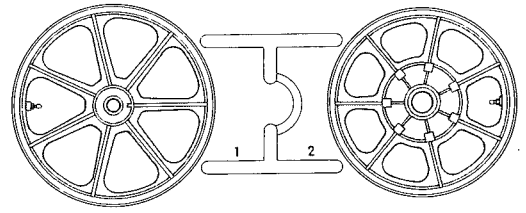

BUILD A COLLECTION OF TAMIYA PRECISION MOTORCYCLE MODELS

KAWASAKI KZ1300B TOURING

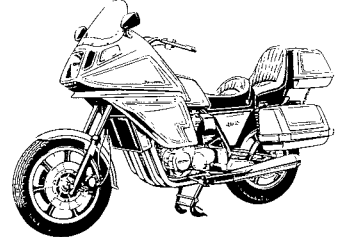

HONDA CB1100R

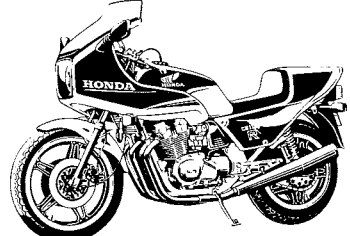

SUZUKI GSX1100S KATANA

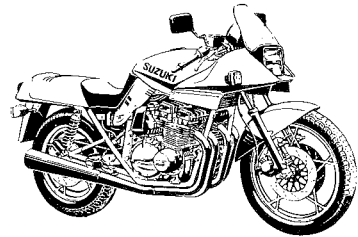

P Parts

Transparent
 Chrome Silver

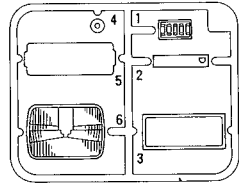

M Parts (Blister Pack)

Red Parts

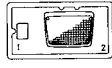

Yellow Parts

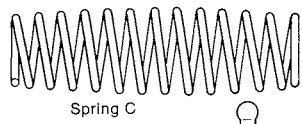
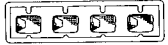

Spring C

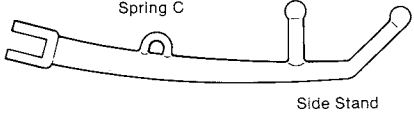

Side Stand

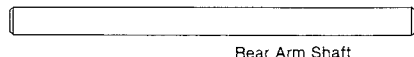

Rear Arm Shaft

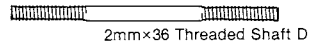

2mm x 36 Threaded Shaft D

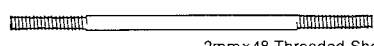

2mm x 48 Threaded Shaft A

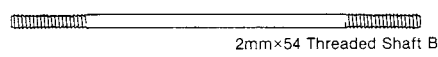

2mm x 54 Threaded Shaft B

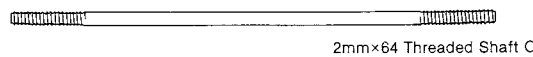

2mm x 64 Threaded Shaft C

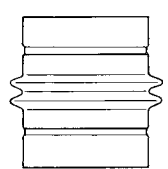

Universal Boot

- Front Tyre
- Rear Tyre
- Inner Struts
- Handle Bar
- Wire Mesh
- Thin Vinyl Tubing
- Thick Vinyl Tubing
- Rubber Tubing

«Metal Bag A»

- 2mm x 10 Screw
- 2mm x 6 Screw
- 3mm x 6 Screw
- Self Tapping Screw
- 2mm x 24 Screw
- 2mm Nut
- 2mm x 28 Screw

«Metal Bag B»

- 2mm x 10 Screw
- 2mm x 4 Screw
- Spring B
- Spring A
- Saddle Metal A
- Saddle Bracket B
- Saddle Hinge