

M41 WALKER BULLDOG

1/35 MILITARY MINIATURE SERIES

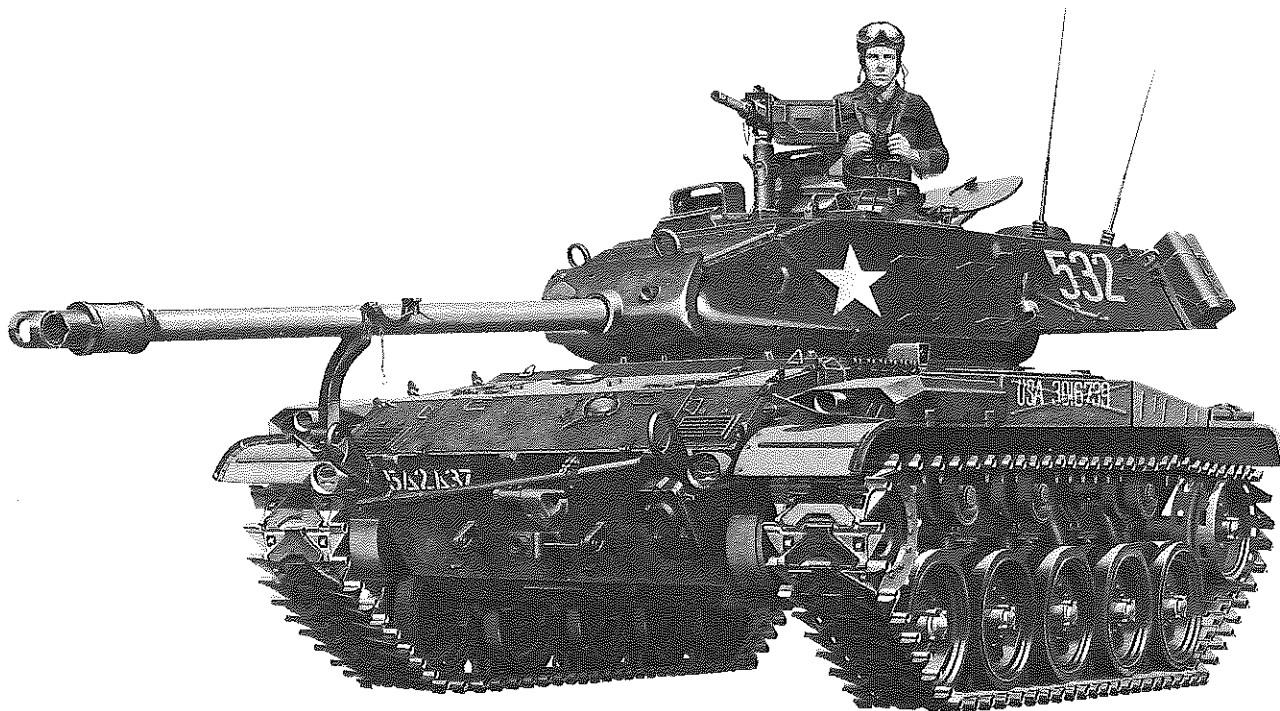

When the 2nd World War ended, the main strength tanks of the U.S. Army were the M-26 General Pershing heavy tanks (41 ton), the M-4 Sherman medium tanks (33.5 ton) and the M-24 General Caffi light tanks, numbering several thousand in all. It was clear, however, that these tanks were inferior to those of the Soviet Army, then the potential enemy of the U.S. in points of fire and combat power. Thus, the U.S. land task forces asked the Army authorities to develop a new, powerful tank, fully equal to the Soviet counterpart.

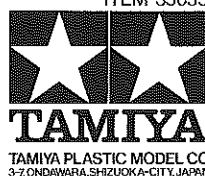
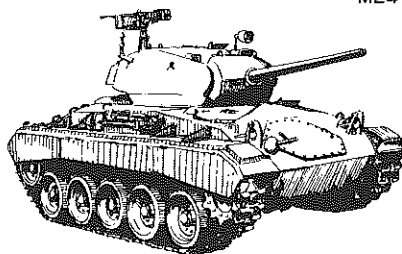

M24

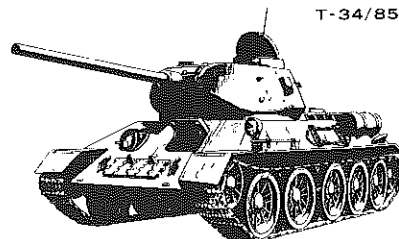

T-34/85

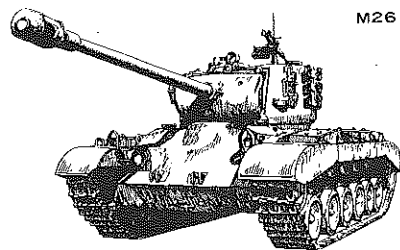

M26

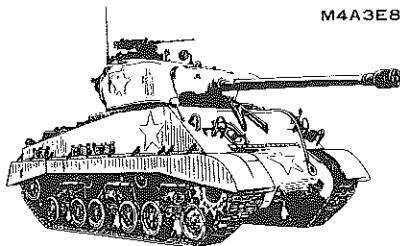

M4A3E8

In 1946, the U.S. Army decided to develop three new types of tanks — light (less than 25 tons), medium and heavy (both less than 45 tons). However, after the war, domestic demands in the U.S. restrained new investments in military developments. Then, the Korean War broke out on June 20, 1950 and the U.S. Army task forces went out to battle using the same old M-24 light and M4A3E8 medium tanks which were employed during the 2nd World War. On the other hand, the main strength of the North Koreans were the Soviet T-34/76 and T-34/85 tanks, which were far superior in their ranges, especially to the U.S. M-24 light tanks. As a result, the U.S. tanks were destroyed and suffered miserable defeats. To remedy the situation, the T-41 trial-made light tank, which was then at the development stage to succeed the M-24, was shipped immediately to the battlefield directly from the production line even before a test run.

The U.S. Army had asked the Cleveland tank plant of the General Motor's Cadillac Car Division to develop the T-41 trial tank. The plant was credited with the production of the M-5 and M-24 and many other military vehicles. The

trial production of the model called the 'T-41 trial light tank' was started at the end of 1947. This trial light tank weighed 24 tons. Its T-91 type main gun was a newly designed, light-weight, 76mm one of high muzzle velocity and was mounted onto a single-piece, 360 degree revolvable, cast-welded gun turret. The gun was geared to a T-37 type, stereo range-finder fixed in the front part of the gun turret and was designed to destroy the enemy tank unflinching with its first shot. The 76mm gun of 60 caliber, with a long barrel, was lighter in weight, longer in effective range (up to 4.5-5 km) and had higher destructive power, than the 76mm of 52 caliber, also with a long barrel mounted on the M4A3E8 medium tank. Other armaments included three M-2 type Browning 12.7 mm heavy machine guns of 50 caliber each, one held in parallel with the main gun and two others on respective anti-air gun holders on the upper gun turret.

As for the power drive system, an air-cooled level-opposite type gasoline engine, called Leicaming 6-cylinder, 500HP gasoline engine, which had been developed by the Arms Office since 1943 for a future tank engine, was adopted together with a cross-drive type automatic transmission. This drive mechanism guaranteed

a high hourly speed of up to 72 km. However, the T-41 in actual battle showed various defects. Especially, there was found one which eventually led to the re-adoption of the then prevalent direct-aiming type range finder instead of the new stereo one when the trial manufactured T-41 E1 light tank was completed in 1951. The stereo type was adopted to get improved aiming, but in actual fighting the sighting of the range finder was distorted due to the firing oscillation.

The T-41 E1 underwent various tests and was much improved, and after two years from its trial-manufacture, it was formally adopted as a M-41 type light tank. The M-41 light tank produced was 1,802 in number and was especially suited for the main strength reconnaissance tank. It was later nicknamed 'Walker Bulldog' in praise of the late General W.H. Walker, nicknamed 'Bulldog', who was killed in action in Seoul during the Korean War.

At the end of 1953, the vertical movement mechanism of the gun barrel was changed from manual, then prevalent, to electromotive in order to improve precision control of the main gun and gun turret revolution. Also, the gun turret revolution mechanism was changed into a newly designed oil pressure drive system. After successful test results, the tank was formally adopted as a M-41 A1 type light tank in June, 1954 and about 1,800 was produced. In addition, four hundred and sixteen of the old M-41 tanks were remodelled to the M-41 A1. Thus, the number of the M-41 A1 tanks reached to about 2,200.

Improvements on the M-41 until 1960 primarily involved that of the engine. This resulted in two kinds of the same tank, in addition to the two latter, the M-41 A2 and M-41 A3. Between the M-41 and the M-41 A1, however, there was a clear outward difference. In the case of the M-41 A1 type, both right and left fenders tapered off sharply at the front and rear ends and a muffler for the auxiliary motor engine was fixed at the front right part of the hull. (See Fig. B). However, the difference between the M-41 A2 and M-41 A3 types were rather slight since the former represented the M-41 A3, only re-fixed with an AOSI-895-5 type, air-cooled, level opposite, 6 cylinder engine which was completed in 1958, while the latter was the M-41 A1 re-fixed with the same engine.

The following engine used was the AOS-805-3

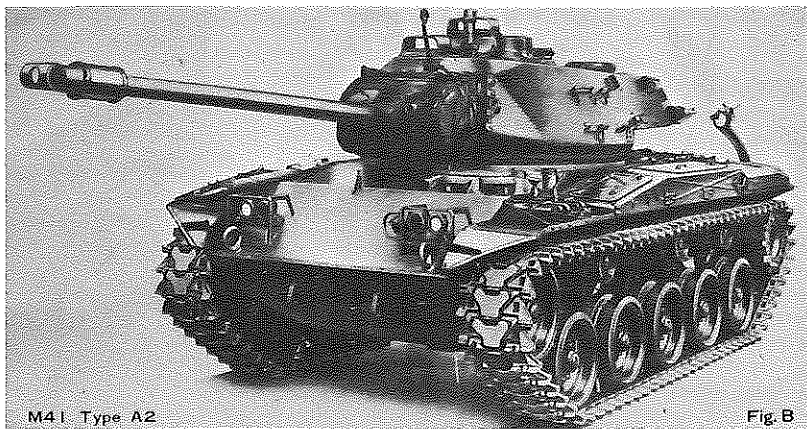

M41 Type A2

Fig. B

type gasoline engine. However, the M-41 equipped with this was limited in power with a maximum speed of 64 km/hr and a cruising radius ranging only from 160 km to 190 km when not refueled. When compared with the Soviet, fitted with a diesel engine, this short radius of action of the U.S. tank was strikingly apparent. The Arms Office, therefore, adopted an automatic fuel jet equipment developed by Britain and re-fitted it to the AOS-805-3 engine. The remodelled engine was the AOSI-895-5 type. This engine had a longer life and cruising distance and was much more powerful than the old AOS-805-3.

Thus, the M-41 type tank was greatly improved since its first model appeared in the Korean War and because of its light weight and compactness in size, this type tanks were placed mainly with the mechanized cavalry regiment of the U.S. Mechanized Division, as light tanks available for air transportation.

In 1956, a large number of the M-41 tanks were supplied to the German Defense Force and used as training vehicles for its newly organized mechanized forces. Later in 1961, one hundred and fifty of the same M-41 tanks were delivered to the Japan Ground Self Defense Force. Together with the 61 type medium tanks, they were the main-strength tanks of the Japanese Force. Meanwhile, the U.S. Army formally

adopted the M-551 type light tank to replace the M-41 in 1968. These tanks were shipped to the fronts in South Vietnam. It is expected that the new M-551 tank will eventually supersede the M-41 in large numbers in actual use as it has many superior capabilities compared to the M-41.

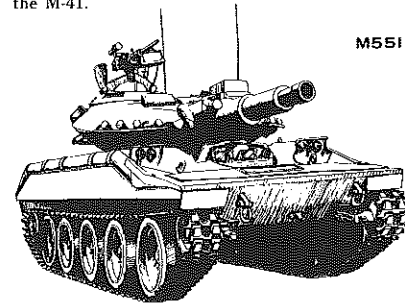

M551



M41



**READ BEFORE
ASSEMBLY.**
**ERST LESEN
— DANN BAUEN.**

- ★You will need a sharp knife, a pair of tweezers, a file, and a pair of pliers.
- ★Study the instructions and photographs before commencing assembly.
- ★Do not break parts away from sprue, but cut off carefully with a pair of pliers.
- ★Overall painting may be done after the whole construction steps. Refer to PAINTING.

1 (Construction of Lower Hull)
Cement Drive Sprocket Shafts A10 & A11 to Hull firmly. Part B8 is a hook which holds Upper Hull.

2 (Fixing of Wheels)
Install wheels and various parts to Lower Hull. Allow Idler Wheels, Road Wheels and Drive Sprockets to revolve freely. Fit Polyethylene Caps in Wheels and cement halves together, and push Wheels in shafts.

3 (Construction of Gun Barrel)
Cement B14 and B15 together and insert pre-assembled Gun Barrel B31 & B32 into B14 with glue.

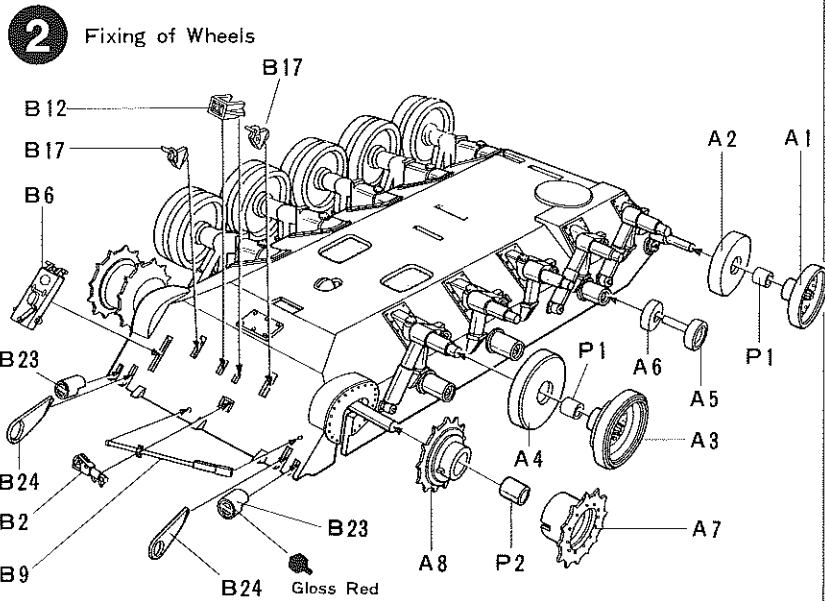
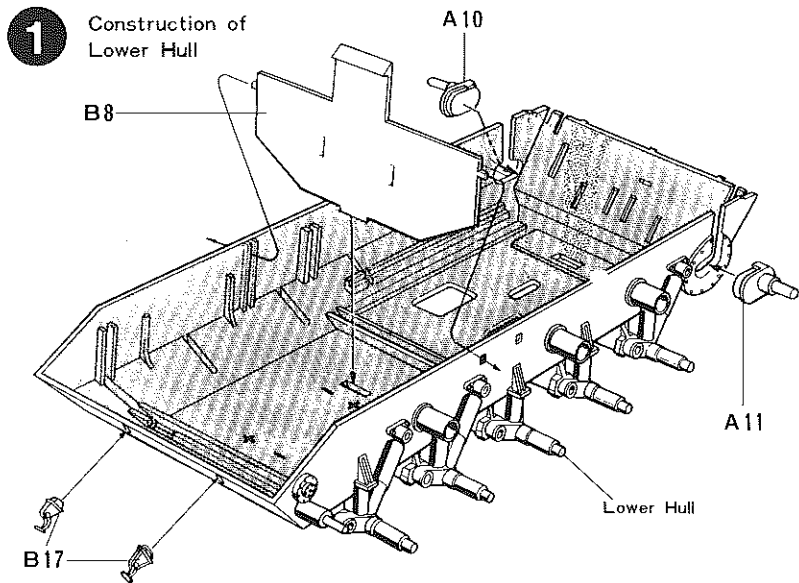
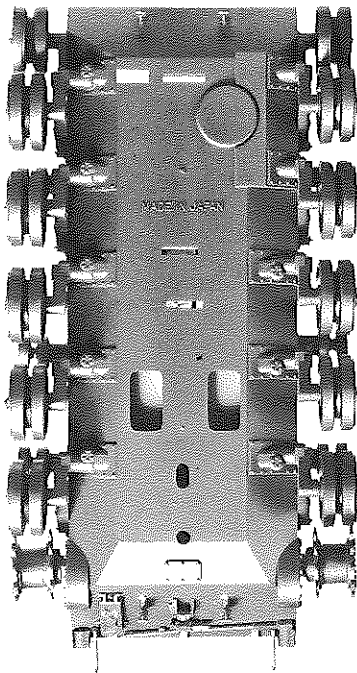

Drive Sprocket

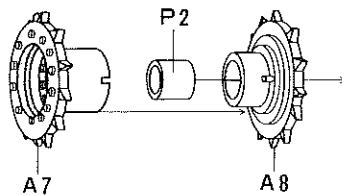

Road Wheel

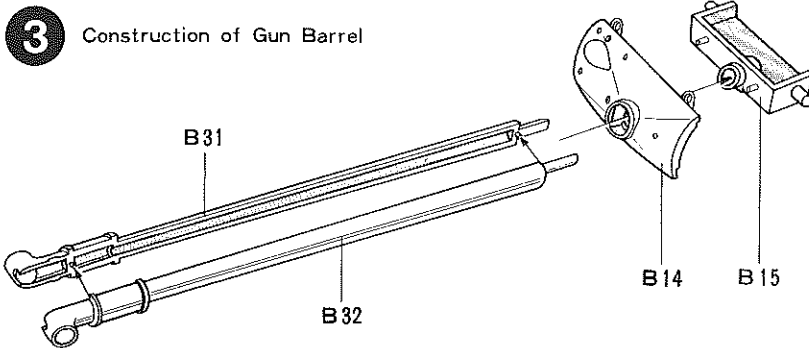
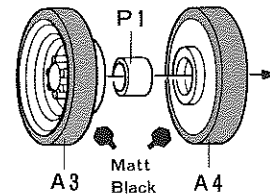

4 (Construction of Turret A)
 Gun Barrel elevates and depresses. Hold it in position with Upper and Lower Turret. Also Hatch B36 is movable, open or closed. Fix this to Turret with B10 and B11. Do not cement Hinges to Hatch. If you prefer to add the gun shield cover, apply it at this step. Refer to the illustration on the following page.

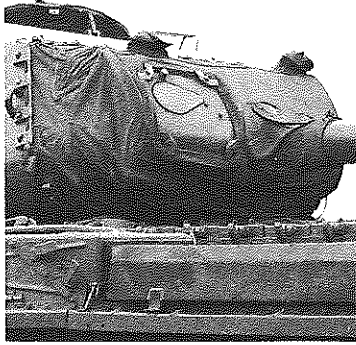

5 (Construction of Turret B)
 Fix various parts to Turret. See the figure below and construct Machine Gun before fixing to Turret.

(Construction of Machine Gun)

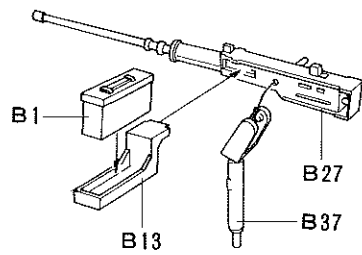

6 (Construction of Upper Hull)
 Do not cement but just fit B4 and B20 in position. Fix B3 referring to the figure below.

(Fixing of B3)

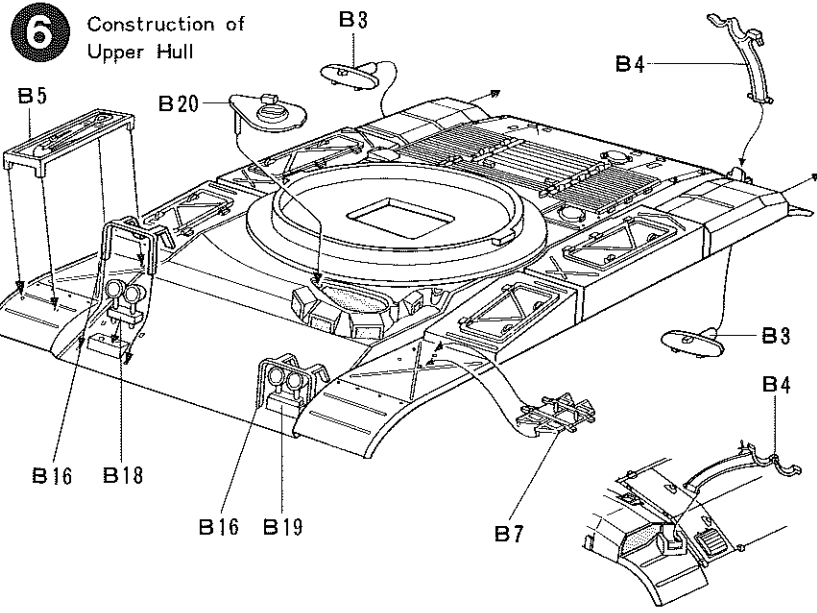
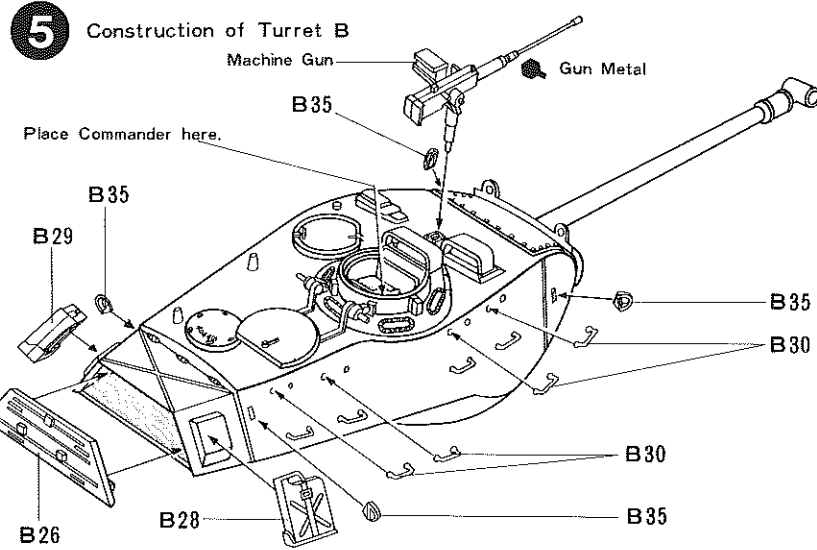
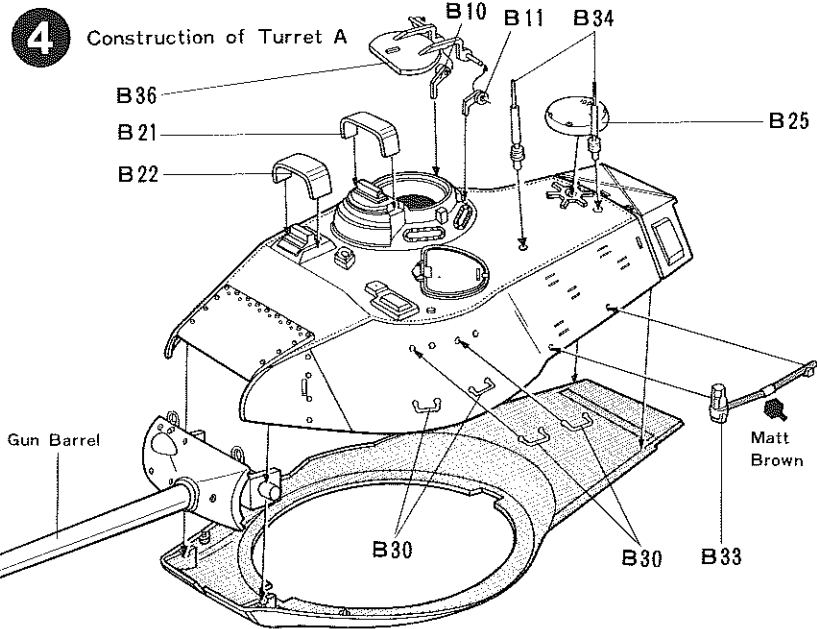
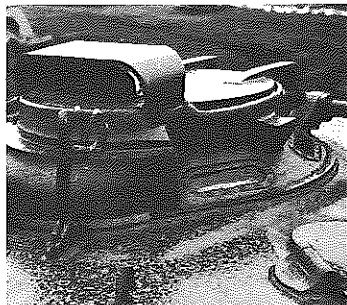
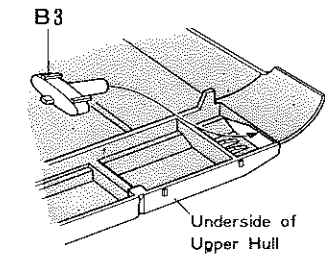

7 (Completion of M41)

Fit Turret in Hull in the position as shown in the figure, and then turn. Joining Upper and Lower Hull together is done by B8. Heat-fix Tracks and mount on wheels making sure of their pattern.

8 (Construction and Painting of Figures)

See the drawings and construct figures. Two infantry are located outside the tank. They may be a realistic addition in diorama. Install Commander as indicated at the step 5.
★Refer to the right photo.

(How to Make Gun Shield Cover)

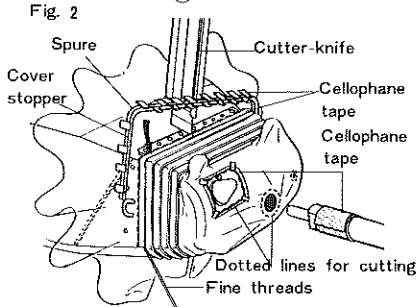
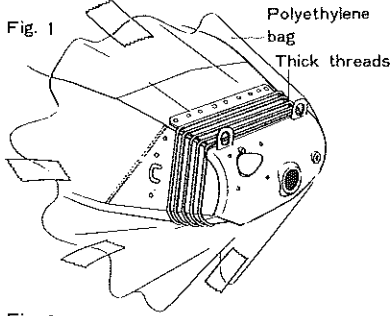

Glue several thick threads about 1mm apart around the head of gun shield as shown in Fig. 1 above. Then, cover the whole with a polyethylene bag in which the kit parts have been contained. Fasten the bag here and there by winding cellophane tapes around, all the while trying to move the crumpled part further back. Next, wind fine threads around the polyethylene covered gun shield as if to fill the space between thick threads as shown in Fig. 2. Warm the whole and fix the shape by a dryer until desired crumple will be formed. When so done, unlace the fine threads and cut the polyethylene along the dotted line as shown in Fig. 2. Then, cover and finish mouth-shaped, cutted edges with cellophane tapes.

7 Completion of M41

★Fit Turret to Upper Hull in this position and turn.

Heat-fix Tracks.

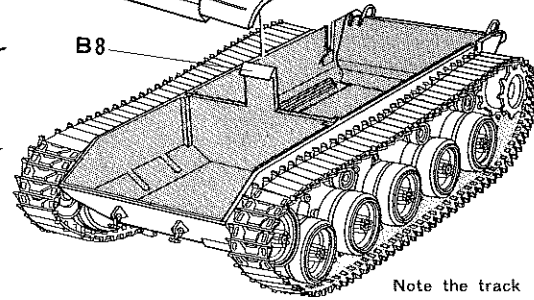
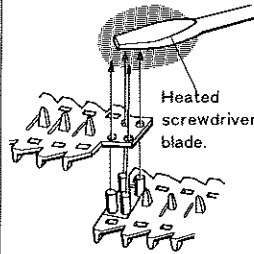

Note the track direction.

8 Construction and Painting of Figures

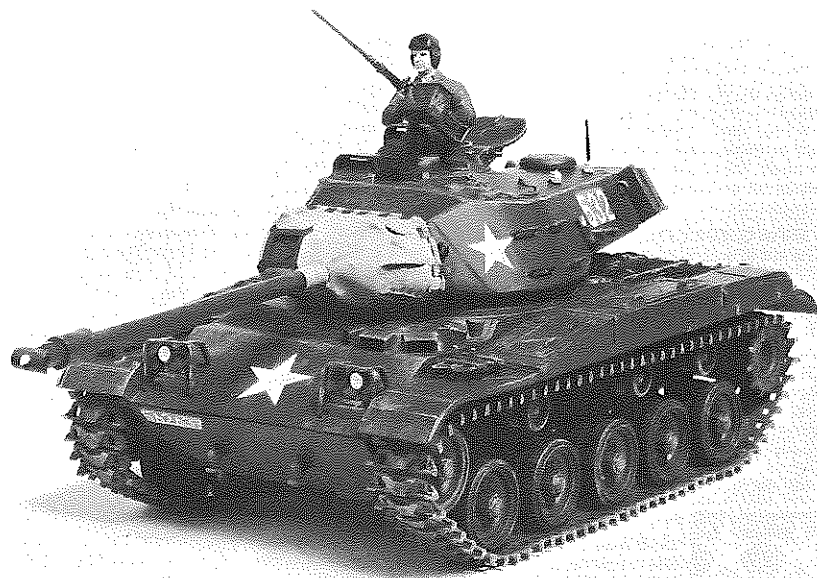
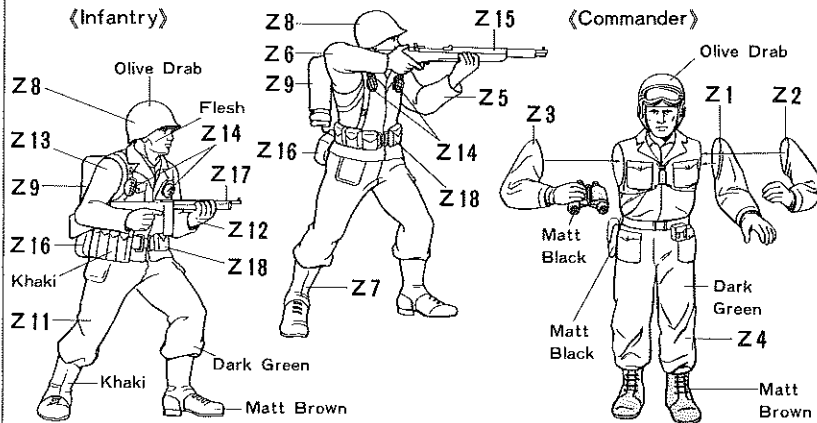

TAMIYA FARBKATALOG IN DEUTSCHER SPRACHE

Letzte Neuheiten von Autos, Booten, Tanks und Schiffen. Im Tamiya-Katalog in deutscher Sprache sind alle Modelle, ob Motorisierte, Ferngesteuerte oder Museum-Qualitates-Modelle, farbig Abgebildet.

PAINTING

APPLYING DECALS

(Painting of M41)

The standard scheme of M41 is single sprayed Olive Drab. Other details are as follows: window and periscopes around commander's hatch.....Silver, upper half circle of taillight.....Gloss Red, headlight (outside).....Silver, (inside).....Matt Black, rubber tyres around road wheels.....Matt Black, machine gunGun Metal, inside of commander's hatch.....Matt White, handle of pick ax and shovel.....Matt Brown.

(Paint to be used)

Use only paint for styrene plastic or enamel. Wide areas may be painted with spray-type paint.

- Matt Black
- Matt Brown
- Gun Metal
- Olive Drab
- Gloss Red
- Silver

The Japan Ground Self-Defence Force(A)

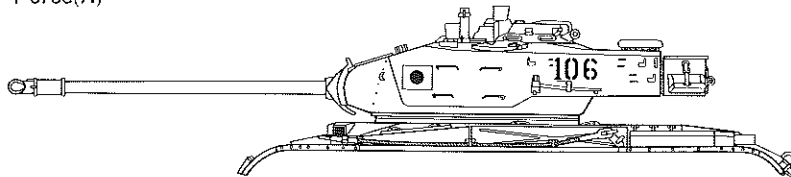

The Japan Ground Self-Defence Force (B)

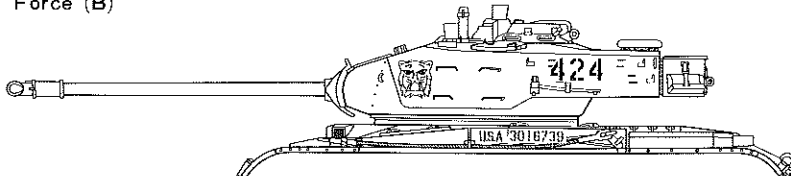

The U.S. Army

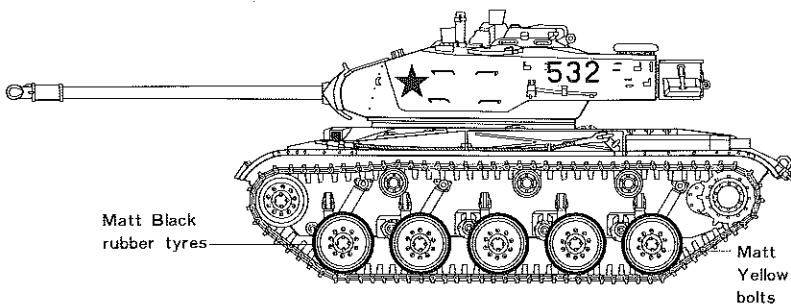

JGSDF (A)

JGSDF (B)

The U.S. Army

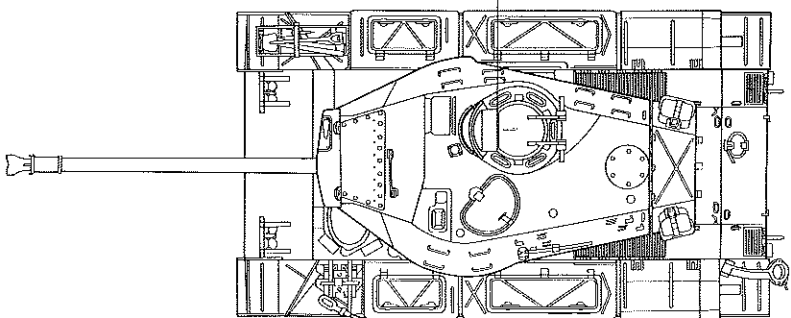
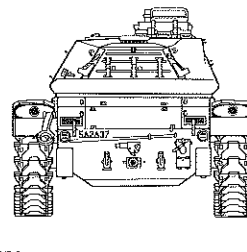
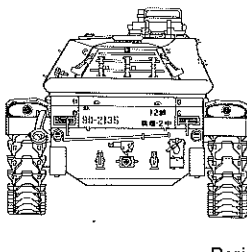
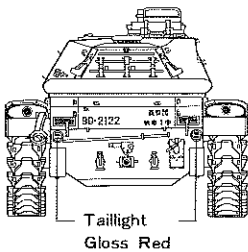
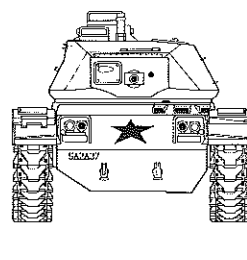
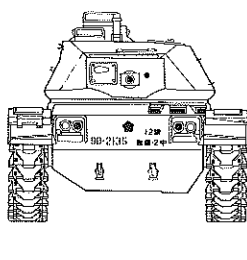
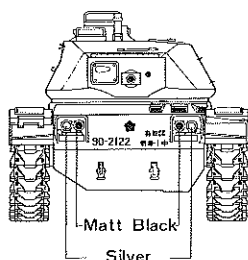

Tamiya Acrylic Paints
Need precise colour matching? Try the new Tamiya acrylic paints. Engineered by modelers for modeler's use. The final cover for the finest models. Insist on Tamiya for perfect results.

TAMIYA COLOR CATALOGUE
The latest in cars, boats, tanks and ships. Motorized, radio controlled and museum quality models are all shown in full color in Tamiya's latest catalogue. At your nearest hobby supply house.

Like to detail your models?
Tamiya has a fine line of photo albums that will help you in the super detailing of your tank models or diorama construction. See them at your nearest Tamiya supply house, or order direct from the factory.

